

YK250 Motocross Motorcycle Maintenance Manual
First Edition (December 2023)

This maintenance manual is a property of TIBET NEW SUMMIT MOTORCYCLE CO., LTD. The contents and pictures in this maintenance manual are for reference only. The actual product shall prevail.

Preface

This motorcycle manual introduces the basic structure, working principle, disassembly and maintenance, fault diagnosis and troubleshooting methods of **YK250 Motocross** Motorcycle to readers in detail. In addition, it also introduces the technical specifications, performance parameters and maintenance adjustment data of this model. This manual is informative, illustrated and practical. We hope that this manual can provide technical support and guidance for KOVE motorcycle users and after-sales service personnel in terms of maintenance.

The technical specifications, performance parameters and maintenance adjustment data marked in this manual are determined according to the latest state. We will improve this model later without notice and may cause any inconsistency between the latest model and that described in this manual. We apologize for any inconvenience caused thereof.

We sincerely hope that you will give us your valuable opinions and comments on the design, manufacture and quality of this model to improve it in time. Thank you for your support and cooperation.

All the information, charts, data, and performance indicators published in this manual are as of the printing of this manual. Please understand that TIBET NEW SUMMIT MOTORCYCLE CO., LTD. reserves the right to modify this manual without prior notice. Any part of this manual is the property of TIBET NEW SUMMIT MOTORCYCLE CO., LTD. No unit or individual is allowed to reprint it without our consent. Otherwise, they will be held legally responsible.

Due to the limited abilities of the editor, errors and omissions are inevitable in this manual. We kindly welcome criticism and correction from users and readers.

TIBET NEW SUMMIT MOTORCYCLE CO., LTD.

Customer service hotline: 400-8818-603

For more information, please visit our website at cn.kovemoto.com

English version editor: December 2023

Contents

Chapter I Overview.....	1
Chapter II Basic information	3
Chapter III Regular maintenance and adjustment	17
Chapter IV Frame, Body Trim, Exhaust System.....	45
Chapter V Cooling System	63
Chapter VI Engine	71
Chapter VII Electronic Fuel Injection (EFI) System	97
Chapter VIII Fuel System	111
Chapter IX Front Wheel, Suspension, Steering	127
Chapter X Rear Wheel, Suspension	139
Chapter XI Hydraulic Brake	151
Chapter XII Electrical Components	163
Chapter XIII Appendix (Schematic).....	184

Chapter I

Overview:

How to use this manual

This manual describes the maintenance procedures of YK250 Motocross.

Chapters II and III apply to the complete motorcycle. Chapter IV describes the procedure for removing/installing components that may be used to provide the services described in the following sections. Chapters 4 to 12 describe the parts of the motorcycle that are grouped according to their positions. If you are not familiar with this motorcycle, please read the technical characteristics in Chapter 2. Please comply with the recommendations in the Maintenance Cycle List to ensure that the motorcycle is in the best running condition and the emission level meets the local environmental protection requirements. Then go to the contents on the first page of this part, most of which start with procedure set or system descriptions, maintenance instructions, and troubleshooting. The detailed process is described in the following pages. Refer to Troubleshooting in each section to eliminate the fault or symptom.

Your safety and the safety of others are very important. To help you make an informed decision, we provide safety information and other information in this manual.

You must use your good judgment, and you will find important safety information in various forms.

Including:

- * Safety labels on the motorcycle
- * Safety Information - Add one of three signal words before the safety warning symbol, i.e. Warning, Caution, or Notice, meaning:

 Warning	[Warning] Symbol. This symbol indicates a dangerous situation. This dangerous situation will lead to fatality or serious injury if not avoided.
--	---











Notes	This is the [Notes] symbol. This symbol indicates the specified precautionary measures that you must follow to avoid damage to the motorcycle or financial loss.
--------------	--

Note	This is the [Note] symbol. This symbol indicates some key information that can make certain procedure steps easy to perform.
-------------	--

Note: How to properly and safely repair this motorcycle.

Symbol

The symbols used in this manual indicate specific maintenance procedures. If supplementary information related to these symbols is needed, they will be explained in detail in the text without using these symbols.

	Replace parts with new ones before assembly
	Unless otherwise specified, use the recommended engine oil
	Use molybdenum oil solution (oil and molybdenum grease are mixed in a ratio of 1:1)
	Multi-purpose high-temperature extreme pressure composite lithium grease (UNIVERSAL SU-T330G/F grease or equivalent product)
	Use molybdenum disulfide grease (SU-T330Y or equivalent product containing more than 3% molybdenum disulfide)
	Use molybdenum disulfide paste (SU-T330Y or equivalent product containing more than 40% molybdenum disulfide)
	Use silicone grease
	Apply thread fastening. Unless otherwise specified, use medium strength
	Apply sealant
	Unless otherwise specified, use the recommended brake fluid. (Use DOT4 brake fluid)
	Use shock absorber oil

Basic information

Section 1 Maintenance instructions	4
Section 2 Model identification	5
Section 3 Basic information	6
Section 4 Torque value—vehicle body	11
Section 5 Lubrication and sealing points - vehicle body	15

Maintenance instructions

1. Please use KOVE original parts and lubricants or equivalents recommended by KOVE. Parts that do not meet the design specifications of KOVE may damage the motorcycle.
2. Use special tools designed for this product to avoid damage and incorrect assembly.
3. Only tools using metric unit can be used to repair motorcycles, and bolts, nuts and bolts using metric unit cannot be interchanged with fasteners using imperial unit.
4. Use new shims, O-rings, cotter pins and lock plates when reassembling.
5. Unless a specific order is specified, when tightening bolts or nuts, start with the one with larger diameter or internal bolts, and then tighten them to the specified torque in diagonal increments.
6. Clean the parts with detergent before disassembly and lubricate all sliding surfaces before reassembly.
7. After reassembly, check all parts for proper installation and operation.
8. Do not bend or twist the control cable as it may get stuck or tangle, causing the vehicle to malfunction.

Abbreviations

In this manual, the following abbreviations are used to identify respective components or systems.

Abbreviations	Full name
DTC	Diagnostic Trouble Code
ECU	Engine Control Unit
ECT sensor	Engine Coolant Temperature sensor
IAT sensor	Intake Air Temperature sensor
MAP sensor	Manifold Absolute Pressure sensor
OBD Service connector	On-Board Diagnostics Service connector
TP sensor	Throttle Position sensor

Model Mark: YK250 - Motocross



Basic Information

	Item	Parameter
Size	L × W × H	2168 x 805 x 1265 mm
	Seat height	960 mm
	Shaft distance	1490 mm
	Ground clearance	340 mm
	Minimum turning radius	-
	Curb weight	101 kg
	Maximum payload	75 kg
	Carrying capacity	1 person
Frame	Frame type	High-strength steel twin-spar frame
	Front shock absorber	Inverted fully adjustable damper shock absorber
	Front shock absorber stroke	303 mm
	Rear shock absorber	Fully adjustable external airbag shock absorber
	Rear shock absorber stroke	132 mm
	Front tire size/model	80/100-21 M/C 51M / CST CM-736
	Rear tire size/model	100/90-19 M/C 57M / CST CM-739
	Front wheel rim	21x WM1.60 / 7050-T6
	Rear wheel rim	19x WM1.85 / 7050-T6
	Front brake/disc	One-way double-piston floating caliper/single brake disc 260 mm
	Rear brake/disc	Single-piston floating caliper / single brake disc 240 mm
	Forward tilt angle	29.36°
Engine	Model	Z179MM
	Displacement	249.9 ml
	Type	DOHC, single-cylinder, water-cooled, four-valve
	Cylinder diameter × stroke	79 mm×51 mm
	Compression ratio	13.9:1
	Maximum power	30 kW / 12,000 rpm
	Maximum torque	27 N·m / 9500 rpm
	Valve mechanism	Dual overhead cam
	Lubrication system	Jet lubrication + Splash lubrication
	Cooling System	Closed coolant circulation cooling

Item		Parameter
Drivetrain	Clutch	Manual wet multi-plate
	Shift mode	Constant-mesh two-stage transmission with five-gear speed shifting
	Reducer gear	5-speed international transmission
	Primary transmission ratio	3.474
	Final transmission ratio	3.846 (50/13)
	Gear transmission ratio	First gear: 2.231; Second gear: 1.75; Third gear: 1.471; Fourth gear: 1.227; Fifth gear: 1.043
	Shift mode/sequence	Mechanical reciprocating type / 1-N-2-3-4-5
Electric system	Ignition mode	ECU-controlled digital ignition
	Starting mode	Electric starting
	Spark plug manufacturer/model	TORCH / BN9RSI
	Spark plug clearance	0.95 – 1.05 mm
	Regulating rectifier	Three-phase full-wave rectification
	Stator coil (resistance)	0.2Ω±20%
	Trigger (resistance)	-
	Maximum magneto output power	-

Specification of EFI System Unit: mm

Item	Specification
Engine idle speed (high/low)	2200±100 r /min
Water temperature sensor (output resistance at 20 °C)	2318-2550Ω
TP sensor (idle) output voltage	0.6-0.8 V
Intake pressure voltage: at 35 kPa	1.365-1.459 V
IAT sensor resistance: at 25°C	1.990-2.123KΩ
Fuel injector resistance (20°C/68°F)	12Ω

Fuel system Specification Unit: mm

Item		Specification
Throttle valve body identification number		-
Fuel pressure at idle speed		300±10kpa
Fuel pump flow (at 12V and 300 ± 10 kPa)		≥30L/h
Fuel supply system	Type	BOSCH EFI
	Throttle orifice	44mm
Fuel type	Gasoline	No.95 GB17930 - 2016
Fuel tank capacity		6.5 L

Lubrication System Specifications Unit: mm

Item		Standard value	Ultimate state
Oil capacity	Drain only from the oil drain bolt	1.0 L	-
	Replace the oil fine filter	1.1 L	-
	Replace the oil fine filter and oil strainer	1.2 L	
	Complete disassembly and reassembly	1.35 L	-
Recommended oil	Brand	-	-
	Model	SAE10W-40	-
	Grade	API service category: SL or above (Do not use energy-saving oils marked with the API "donut" symbol)/ JASO T903 Standard: MA/ GB 11121-2006	-
Engine oil filter type		Full flow paper filter element	
Oil pump rotor	Internal and external rotor clearance	0.15	0.20

Cooling System Specification Unit: mm

Item		Specification	Ultimate state
Coolant capacity	Radiator (including all water channels)	1.2 L	-
Radiator cap relief pressure		1.7bar	-

Hydraulic Brake Specifications Unit: mm

Item		Standard	Ultimate state
Front brake	Designated brake fluid	DOT4	-
	Total thickness of brake pads	8.00	To groove
	Brake disc thickness	3.00	2.5
	Brake discs runout	0.08	0.15
	Inner diameter of master cylinder	11.00	-
	Brake caliper piston inner diameter/1	27.00	-
	Brake caliper piston inner diameter/2	30.20	-
Rear brake	Specified brake fluid	DOT4	-
	Total thickness of brake pads	9.60	To groove
	Brake disc thickness	3.00	2.5
	Brake discs runout	0.08	0.15
	Inner diameter of master cylinder	9.52	-
	Inner diameter of brake caliper piston cylinder	22.62	-

Front Wheel/Suspension/Steering System Specifications Unit: mm

Item wheel		Standard	Ultimate state
Tire tread depth		13	Tire wear limit marks at [△] TW1 mark on sidewall and center of tire
Tire pressure		100 kPa(1.0 kgf/cm ³ , 15 psi)	-
Shaft runout		0.05	0.1
Rim runout	Radial	0.8	1.0
	Axial	0.8	1.0
Front shock absorber	Free length of spring	475	-
	Tube runout	-	0.2
	Shock absorber oil specifications	AMSOIL Thunderbolt High-Performance Shock Absorber Oil 10W	
	Shock absorber fluid adding capacity	Shock absorber inner chamber (damper): 260±3 mL Shock absorber outer chamber (spring chamber) 350±3ml Equal amount of filling for both sides	

Rear Wheel/Suspension/System Specifications Unit: mm

Item		Standard	Ultimate state
Tire tread depth		17	Tire wear limit marks at [△] T.W.1 mark on sidewall and center of tire
Tire pressure		100 kPa(1.0 kgf/cm ³ , 15 psi)	
Shaft runout		0.05	0.1
Rim runout	Radial	0.8	1.0
	Axial	0.8	1.0
Drive chain	Size/link	Choho 520ND-114 Link	-
	Slack	35-45	-
Rear shock absorber	Free length of spring	238	
	Shock absorber oil specifications	AMSOIL Thunderbolt High-Performance Shock Absorber Oil 10W	
	Shock absorber oil adding volume	380±3ml	
	Nitrogen volume of gas cylinder	1.2 MPa (standard)	

Battery/Charging System Specifications Unit: mm

Item		Specification	
Battery	Model	HJ12-FPZ	
	Capacity	12V23Ah	
	Leakage value	It can be stored for more than one year at 25 °C, and the higher the temperature, the shorter the storage time.	
	Voltage (28 °C, 68°F)	Fully charged	>13.2V
		Need to be charged	<12.8V
	Charging current	Normal	1.2A
Fast		12A	
Magneto	Charging capacity	8000r/min > 8.5A	
	Charging coil resistance (28 °C, 68 °F)	0.2Ω±20%	

Torque Value—Vehicle Body

Installment position	Specification status	Torque force value N·m	Notes
Seat cushion assembly and rear tailgate	M6	8	
Fuel tank center (seat cushion stopper bushing mounting point)	M5	5	
Fuel tank front trim (left and right) and radiator	M5	5	Step
Front fuel tank trim (left and right) and fuel tank	M5	5	Step
Fuel tank front trim (left and right) and frame	M5	5	Step
Fuel tank front trim (left and right) and subframe	M5	5	Step
Vehicle body (left and right) and subframe	M6	8	Step
Rear tailgate (upper) connected to subframe	M6	8	Step
Rear tailgate (lower) connected to subframe	M6	8	Step
Tailpipe plug and subframe	M6	5	Step
Rear splash guard and front section of rear fender	ST4.8	2	
Front windshield and upper connecting plate	M5	5	Step
Front brake oil pipe clip and lower connecting plate	M6	10	Step
Front fender and lower connecting plate	M6	12	
Front brake hose pressure plate and left front shock absorber trim	M5	3	
Front shock absorber trim (left and right) and front shock absorber bottom cylinder	M6	8	Step
Front wheel axle locking (nut)	M16	88	
Front shock absorber bottom cylinder (left and right) locking	M8	22	
Front brake discs and wheel hub	M6	12	(Sealing)
Front brake caliper and left front shock absorber	M8	32	(Sealing)
Brake hose and front brake caliper	M10x1.25	32	
Brake hose and front brake pump	M10x1.25	32	
Front brake caliper and exhaust bolt	M6	9	
Front brake caliper bracket and main/sub sliding shaft bolts	M8	20	(Sealing and oiling)
Front brake caliper brake pad guide pin	M10	15	
Upper connecting plate and front shock absorber (locking)	M8	22	
Lower connecting plate and front shock absorber (locking)	M8	22	
Handlebar switch (right) and handlebar	M4	4	
Handlebar switch (left) and handlebar	M4	3	
Clutch lever and mounting base	M6	8	
Clutch lever shoulder bolt	M6	6	
Clutch cable adjustment nut (lower)	M8	8	
Throttle and handlebar	M6	8	
Throttle cable adjustment nut (handlebar side)	M6/M7	5	
Throttle cable A/B (throttle end)	M6	4	
Front brake pump body and mounting base	M6	8	

Installment position	Specification status	Torque force value N·m	Notes
Front brake pump reservoir cover mounting screw	M4	1	
Front hand brake lever shoulder bolt	M6	5	
Front brake pump rocker arm adjustment assembly	M5	6	
Steering handlebar and upper/lower socket	M8	22	
Steering handlebar lower socket and upper end of special through bolt	M8	30	(Sealing)
Upper connecting plate and upper end of special through bolt (self-locking nut)	M8	22	
Fastening nut between upper connecting plate and steering stem	M24x1	108	(Shim lubrication)
Engine lower protector and frame	M5	5	Step
Front sprocket cover, chain baffle and engine	M6	10	
OBD diagnostic interface and fuel tank	M5	2	
Front of fuel tank and frame	M6	10	
Rear of fuel tank and frame	M6	10	
Fuel pump and fuel tank	M5	4	
Radiator and radiator grille	M5	5	
Radiator (left and right) and frame	M6	10	
Muffler heat shield mounting screw	M5	5	
Muffler front section and exhaust port (nut)	M8	16	
Muffler rear section and front muffler section (pipe clamp)	M7	22	
Muffler rear section and subframe (front)	M8x20	22	
Muffler rear section and subframe (rear)	M8x20	22	
Regulating rectifier and air filter box housing	M6x20	10	
Battery box and battery box cover	M5	5	Step
Battery terminal mounting bolt	M5	5	
Battery box and frame	M5	8	
Battery box and engine upper suspension (left)	M5	8	Step
Front and rear rim spoke nipple caps	M4	6	
Front and rear tire clamp locking nuts	M8	12	
Guide sprocket and subframe	M8	22	(Sealing)
Fuel injector cap and throttle body	M6x20	8	
Starting motor and engine case	M6x30	10	
Starting motor to positive wire connecting nut	M6	6	
Starter relay terminal installation	M6	5	
Shift rocker arm and engine	M6	10	
Rear brake pedal and brake rocker arm	M5	8	(Sealing)
Rear brake rocker arm and frame	M8	22	(Sealing)
Rear brake pump and frame	M6	12	(Sealing)
Rear brake pump reservoir cover fastening bolt	M4	2	

Installment position	Specification status	Torque force value N·m	Notes
Brake hose and rear brake cylinder	M10x1.25	32	
Rear brake hose and rear brake caliper	M10x1	32	
Rear brake pump push rod adjusting and tightening nut	M6	6	
Oil pipe clamp and swingarm	M5	5	
Rear brake caliper bracket upper and lower slide shaft bolt	M8	20	(Sealing and oiling)
Rear brake pad guide pin (bolt)	M10	15	(Sealing)
Rear brake caliper and exhaust bolt	M6	9	
Rear wheel axle locking nut	M22x1.5	128	
Drive chain adjusting block locking nut	M8	16	
Rear brake discs and wheel hub	M6	12	(Sealing)
Rear sprocket and rear wheel hub	M8	38	
Chain guide and swingarm	M6	10	
Chain guide and chain guide wear block	M5	5	
Chain clip with swingarm	Philips screw	8	(Sealing)
Rear shock absorber upper mount to frame	M10	44	
Rear shock lower mount to triangular cradle	M10x1.25	44	
U swingarm (left and right) and frame	M10x1.25	60	
U swingarm (left and right) and triangular cradle	M12×1.25	60	
Triangular cradle and swingarm	M12	60	
Swingarm axle locking nut	M16x1.5	88	
Drive sprocket locking (bolt)	M10	60	(Sealing)
Lower chain slider and frame	M6	10	
Engine upper suspension (left and right) and engine	M10	54	
Engine upper suspension (left and right) and frame	M8	36	
Engine front suspension (left and right) and frame	M8	26	
Engine front suspension(left and right) and engine	M10	54	
Engine lower-front suspension and frame	M10	54/60	
Engine lower-rear suspension and frame	M10	54/60	
Subframe (upper and lower) and main frame	M8x25	34	(Sealing)
Air filter housing and subframe	M5	5	Step
Throttle eccentric wheel cover	M5	2	

Installation position	Specification status	Torque force value N·m	Notes
Engine water pump drain bolt	M6	10	
Engine oil filter cap	M6	10	
Quick shifting sensor and engine	M5	6	
Gear sensor and engine	M4	6	
Harness pressure plate (left and right) and frame	M6	8	Step
Frame trims (left and right) and frame	M5	5	
Rear fender and rear air filter tank housing	ST4.8	2	
Air filter tank to metal strainer	ST4.8	2	
Air filter intake hose (clamp)	M5	5	
Engine intake pipe assembly (clamp)	M5	5	
Ignition coil baffle and cylinder head	M6	10	
Rear shock absorber spring locking (nut)	M60	44	
Front shock absorber bleed screw	M4	1.3	
Front shock absorber spring chamber adjustment cap	M50	30	
Handlebar grip mounting screw	M5	7	
Steering stem locking nut (4-slot nut, 8-slot nut)	M25x1	First torque to 40N·m, then loosen and torque to 10N·m, and finally back off by 1/4 turn	

Lubrication and sealing points - vehicle body

Material	Position	Notes
High-temperature extreme pressure composite lithium grease (Universal SU-T330Y)	Contact area of upper and lower bearings and steel bowls of steering stem	
	Dust-proof seal of steering bearing	
	Contact area between steering stem locking nut and shim with upper connecting plate	
	Needle roller bearings and thrust bearings inside rear swingarm	
	Needle roller bearing in U swingarm rotation area	
	Needle roller bearing in triangular cradle rotation area	
	Throttle handle cable groove and rolled area	
	Clutch control lever sliding area	
	Rear brake arm pivot rotation area	
	Sliding area of smooth portion of front brake caliper upper and lower guide pins	
	Contact area of smooth portion of guide pin of front brake caliper	
	Contact area of front brake upper pump tappet and piston combination rocker arm	
	Contact area of smooth portion of hand brake lever bolt	
	Sliding area of smooth portion of upper and lower sliding shafts of rear brake caliper	
	Contact area of smooth portion of guide pin of rear brake caliper	
Contact area of push rod and piston of rear brake upper pump		
High-temperature extreme pressure composite lithium grease (Universal SU-T330Y)	Contact area of seal ring lip of front wheel hub bearing	
	Contact area of seal ring lip of rear wheel hub bearing	
	Contact area of oil seal lip of rear swing arm	
	Contact area of oil seal lip of U swingarm bearing	
	Contact area of oil seal lip of triangular cradle bearing	
	O-ring seal in the front/rear wheel shaft bushing	
Use silicone grease	Contact area of dustproof washer, seal ring, and piston of front brake caliper	
	Contact area of front and rear cups and piston of front brake upper pump	
	Contact area of dustproof washer, seal ring, and piston of rear brake caliper	
	Contact area of front and rear cups and piston of rear brake upper pump	
Shock absorber fluid specialized	Seal lip of front shock absorber oil seal	
	Dust-proof seal lip of front shock absorber	
	O-ring of front shock absorber end cover	
Cable lubricant	Clutch cable	
	Seat lock cable	
	Throttle cable	
Special chain lubricant or equivalent	Entire surface of chain	

Material	Position	Notes
Thread locking agent (huitian 7272)	Front/rear brake disc mounting bolts	
	Left and right front engine suspension to frame	
	Engine upper suspension (left and right) - frame	
	Steering handlebar lower socket and special through bolt	
	Driving sprocket mounting bolt	
Thread fastening (huitian 7262)	Front brake caliper bracket and front shock absorber bottom cylinder	
	Subframe (upper and lower) and main frame	
	Rear brake master cylinder and frame	
	Rear brake rocker arm and frame	
	Rear brake rocker arm and pedal	
	Chain clip with swingarm	
	Guide sprocket and subframe	
	Front shock absorber trim (left and right) and shock absorber bottom cylinder	
	Engine lower protector and frame	

Regular maintenance and adjustment

Section 1 Maintenance information	18
Section 2 Maintenance interval table	19
Section 3 Inspection of spark plug	20
Section 4 Inspection and adjustment of valve clearance	21
Section 5 Camshaft decompression system inspection	21
Section 6 Engine oil inspection and replacement	29
Section 7 Inspection and replacement of engine oil filter	30
Section 8 Inspection of exhaust pipe	31
Section 9 Vehicle starting (choke lever)	31
Section 10 Adjustment of front hand brake lever	31
Section 11 Cleaning and replacement of air filter sponge element	32
Section 12 Inspection and adjustment of clutch free play	33
Section 13 Inspection and adjustment of accelerator free stroke	34
Section 14 Lubrication of front brake handle	35
Section 15 Lubrication of rear brake rocker arm	35
Section 16 Lubrication of clutch handle	35
Section 17 Inspection and lubrication of pedal	35
Section 18 Inspection and adjustment of steering head	36
Section 19 Inspection and lubrication of front and rear wheel bearing seal	36
Section 20 Inspection and lubrication of steering head Bearing	37
Section 21 Inspection and Lubrication of triangular cradle	37
Section 22 Inspection and lubrication of swingarm axle	37
Section 23 Inspection and lubrication of U-cradle	37
Section 24 Adjustment of steering handlebar position	38
Section 25 Inspection of front shock absorber	39
Section 26 Inspection of rear shock absorber	39
Section 27 Inspection of shock absorber wear ring	40
Section 28 Adjustment of air pressure inside front shock absorber	40
Section 29 Front shock absorber settings and adjustments	41
Section 30 Rear shock absorber settings and adjustments	42
Section 31 Battery inspection and charging	44

Maintenance Information

Overview:

This chapter contains all relevant information for conducting the recommended inspections and adjustments. Regular implementation of these maintenance procedures will make motorcycle operation smoother, extend its lifespan, and reduce maintenance costs. The information described in this Chapter applies to motorcycles both already in use and sold yet.

All maintenance technicians shall be familiar with all the information described in this Chapter.

Maintenance Interval Table

During each regular maintenance period, please conduct a pre-driving inspection.

I: inspect, clean, adjust, lubricate or replace if necessary. C: Clean. R: Replace. A: Adjust. L: Lubricate.

Item	Frequency	Notes	Each use for approximately 2.5 hours	Every 3 races for approximately 7.5 hours	Every 6 races for approximately 15 hours	Every 9 races for approximately 22.5 hours	Every 12 races for approximately 30 hours
Gasoline pipeline	(Notes 6)		I				R, *
Fuel pump filter element	(Notes 6)						R, *
Accelerator stroke clearance adjustment			I				
Air filter	(Notes 1)		C				
Crankcase vent pipe			I				
Spark plug			I				
Valve clearance	(Notes 4)				I, *		
Engine lubricant	(Notes 3) (Notes 5)		I		R		
Engine oil filter element	(Notes 3)				R		
Engine idle speed check			I				
Piston ring					R, *		
Piston pin					R, *		
Radiator coolant	(Notes 2)		I				
Cooling System			I				
Drive chain			I, L	R			
Chain guide/chain clip			I				
Guide sprocket/guide chain slider			I				
Driving sprocket			I				
Driven sprocket			I				
Brake fluid	(Notes 2)		I				
Brake pad wear			I				
Brake system			I				
Clutch system	(Notes 5)		I				
Control cable			I, L				
Exhaust pipe/muffler			I				
Friction ring			I				
Swingarm/Shock absorber connecting rod mechanism				L, *			
Front shock absorber oil	(Notes 3)					R, *	
Nut and bolt fastener			I, *				
Wheels/tires			I				
Steering head bearing						I, *	

We recommend that you refer to KOVE official maintenance manual to repair these items.

This maintenance plan is based on average riding conditions. Frequent use of the vehicle requires more frequent maintenance.

- Note:**
- Clean your motorcycle promptly after each ride.
 - Replace every two years and mechanical components are required for replacement.
 - Replace after the first running-in period.
 - Inspect after the first running-in period.
 - Replace the engine oil if the clutch friction plate is replaced.
 - Replace annually.

Mark*For safety reasons, we recommend that these items be serviced only by the dealer.

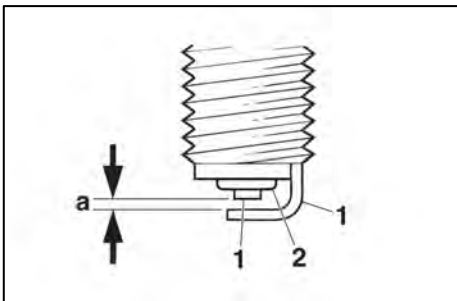
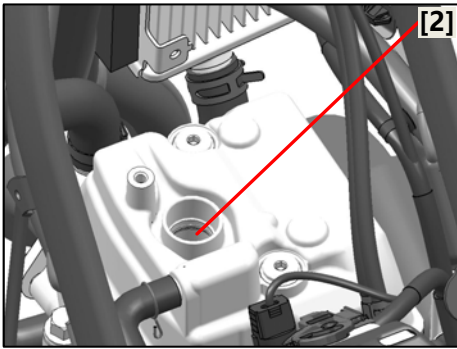
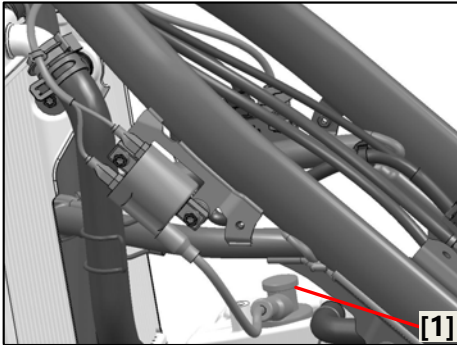

Notes

- Before installing the spark plug, clean the surfaces of the spark plug and the shim first.

※ Inspection of spark plug

1. Stand the vehicle on a flat ground.



- The vehicle shall be supported firmly without the danger of overturning.

2. Disassembly

- Seat cushion assembly
- Front front trim assembly

See "Frame, body trim and exhaust system" on page 45 for details.

- Fuel tank assembly

See "Fuel system" on page 111 for details.

3. Disassembly

- Ignition coil pressure plate screw [1];
- Ignition coil pressure plate [2];
- Plug [3], ignition coil [4], spark plug [5].

Notes

- Before removing the spark plugs, use an air gun to blow around the spark plug seats while ensuring no dust falls into the cylinder.

4. Inspection

- Spark plug type

Mistake → Replace.

Manufacturer/model

TORCH/BN9RSI

5. Inspection

- Electrode "1"

Damage/Consume → Replace the spark plug.

- Insulator "2"

Abnormal color → Replace the spark plug.

The normal color shall be tan or light tan.

6. Cleaning

- Spark plug
(using spark plug detergent or wire brush)

7. Measurement:

- Spark plug clearance "a"
(measured with a feeler gauge)

Non-conformance → Replace.

Spark plug clearance

0.95-1.05 mm

8. Install

- Spark plug and ignition coil pressure plate

Install the above components and tighten them to the specified torque:

Spark plug

22 N·m (2.2 kgf·m, 16 lbf·ft)

Ignition coil pressure plate mounting bolt

10 N·m (1.0 kgf·m, 7.0 lbf·ft)

※ **Valve clearance**

▲ **Note:**

- Before checking or adjusting the valve clearance, ensure the engine is in a cold state (below 35°C/95°F)

□ **Valve clearance inspection**

Remove the motorcycle fuel tank according to the maintenance manual to expose the engine cylinder head cover. Clean the area around the spark plug base with compressed air before disassemble to prevent debris from entering the combustion chamber.

- Disconnect the spark plug cap [1].
- Remove the spark plugs [2].
- Disconnect the cylinder head's breather hose [3] (if the motorcycle is configured to connect to the air filter).
- Disconnect the ignition coil connector (refer to the motorcycle maintenance manual).
- Remove the ignition coil mounting bolt and ignition coil (refer to the motorcycle maintenance manual).
- Remove the cylinder head cover bolt [4], rubber grommet [5], and cylinder head cover [6].

▲ **Note:**

- Prevent the spark plug bore seal ring from falling out[1].
- Check if the seal ring [2] on the cylinder head is damaged.

Remove the timing inspection hole cover [1] and O-ring [2].

Disassemble the left decorative cover [3] and O-ring [4] from the left front cover.

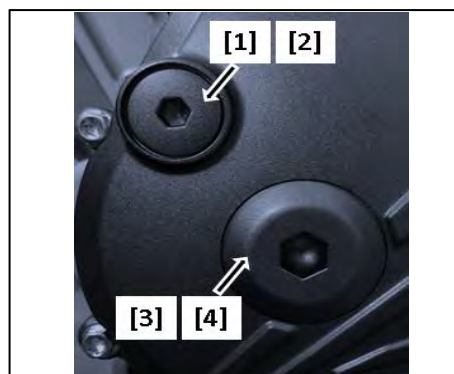
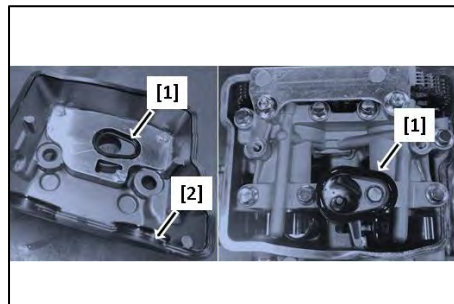
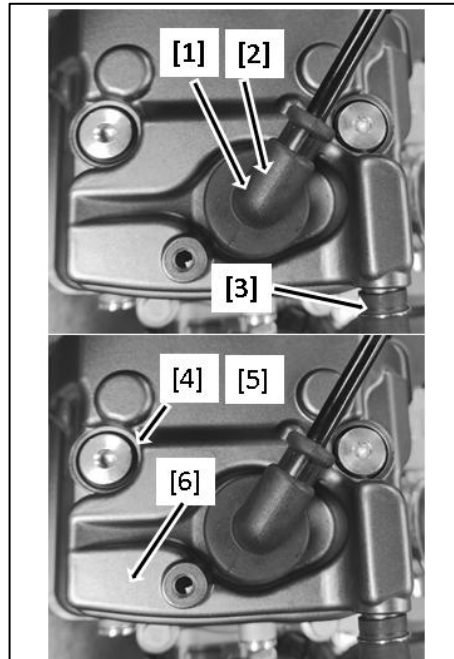

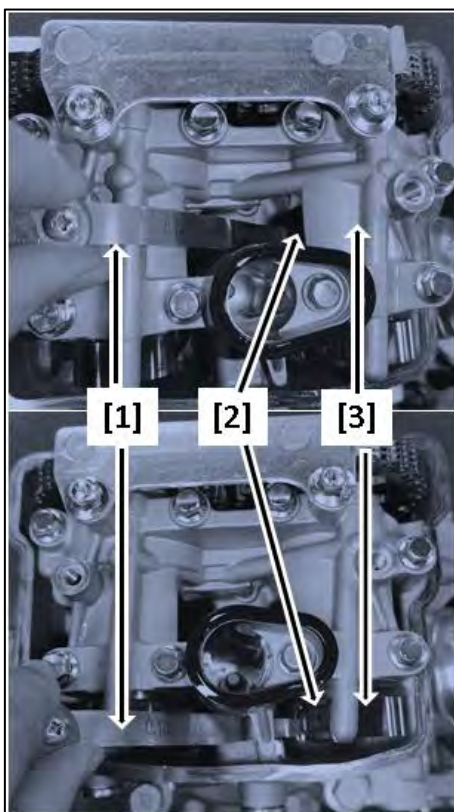
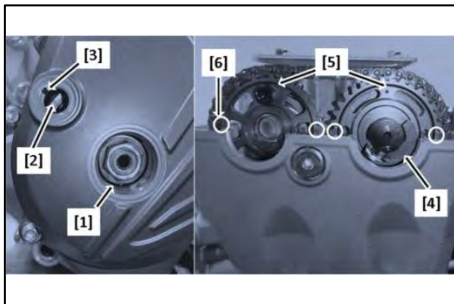

Verify Timing Position

Rotate the magneto flywheel nut [1] counterclockwise to align the timing mark "I" [2] on the flywheel with the timing groove [3] on the left front cover.

Check that the decompression valve flyweight [4] is in the position shown in the figure.

Check the timing mark "O" position [5] and index line position [6] of the camshaft sprocket as shown in the figure.

▲ Note:

- If the decompression valve flyweight is in the position shown in the figure, the piston is at the top dead center (TDC) of the compression stroke.
- If the position of the decompression valve flyweight is opposite, the piston is at TDC of the exhaust stroke. Rotate the crankshaft counterclockwise one full turn, and realign the timing mark on the magneto flywheel with the index line on the left front inspection cover bore.

Check that the timing mark "O" [5] on each camshaft sprocket is positioned at the top, the index line [6] on the intake and exhaust camshaft sprockets are aligned, and flush with the end face of the cylinder head cover.

Use a feeler gauge to check the intake valve clearance.

Insert the feeler gauge [1] between the working arc surface of the intake rocker arm and the base circle surface of the intake camshaft.

Intake valve clearance: 0.1 ± 0.03

▲ Note:

- Be careful not to damage the intake rocker arm.
- If adjustment is required, record the valve clearance for each valve as a reference when selecting shims.

If the clearance does not meet specification, please adjust the valve clearance.

Use a feeler gauge to check the exhaust valve clearance.

Insert the feeler gauge between the exhaust rocker arm working arc surface [3] and the base circle [2] of the exhaust camshaft.

Exhaust valve clearance: 0.2 ± 0.03

▲ Note:

- Be careful not to damage the exhaust rocker arm.
- If adjustment is required, record the valve clearance for each valve as a reference when selecting shims.

If the clearance does not meet specification, please adjust the valve clearance.

Restore after valve clearance inspection

Replace with the new O-ring [1]. Apply engine oil to the O-ring and install it on the inspection cover [2].

Install the inspection cover onto the left front cover and tighten it to the specified torque.

Torque value: 6 N·m

Replace with the new O-ring [3]. Apply engine oil to the O-ring and install it on the left decorative cover [4].

Install the left decorative cover onto the left front cover and tighten it to the specified torque.

Torque value: 15 N·m

Check the spark plug bore seal ring [1] and cylinder head seal ring [2]. If damage or deterioration, replace them.

Install the spark plug bore seal ring [1] and snap it onto the camshaft bracket spark plug bore.

Install the cylinder head seal ring [2] into the groove on the cylinder head mating surface.

As shown in the figure, apply the end sealant to the two semi-circular corner positions of the cylinder head gasket [3].

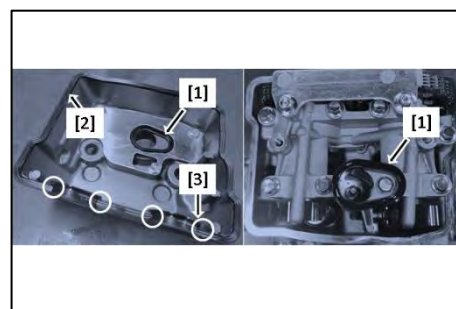
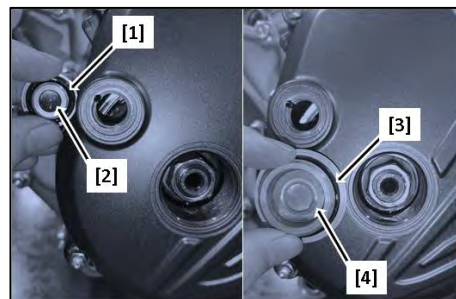
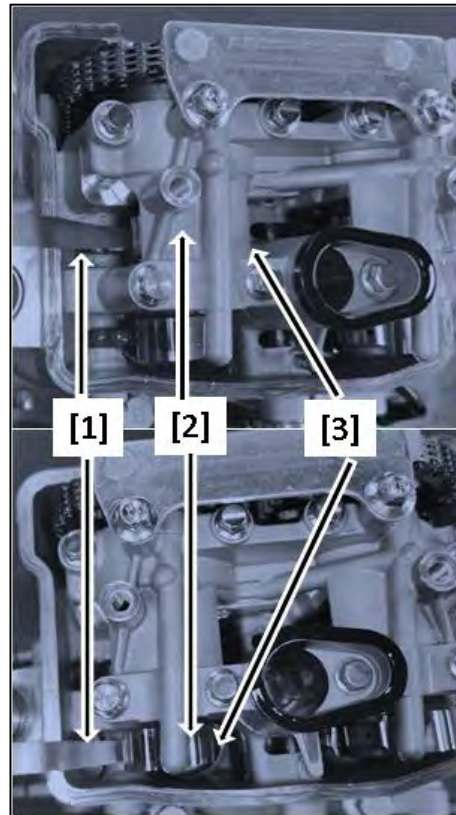

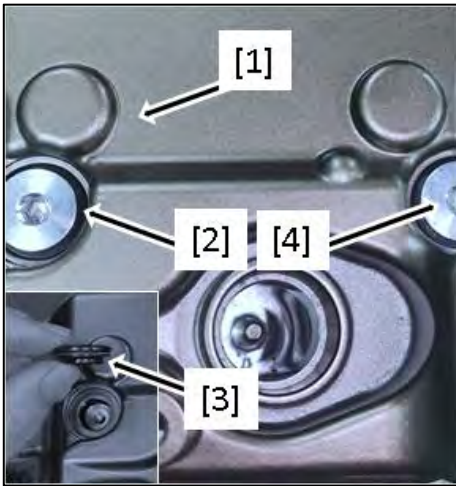

Install the cylinder head cover [1].
Check the bolt rubber grommet [2] and replace if damage or deterioration.

Install the rubber grommet into the groove of the cylinder head fastening bolt with the sealing surface facing downward [3].

Install and tighten the cylinder head bolt [4] to the specified torque.

Torque value: 10 N·m

After that, install the ignition coil according to the motorcycle maintenance manual, connect the ignition coil connector, install the spark plug cap, connect the breather hose between the air filter and the cylinder head (if the motorcycle is configured to connect to the air filter), and reinstall the motorcycle fuel tank.

※ **Valve clearance adjustment**

Disassemble the following parts:

- Left trim cover
- Inspection cover
- Cylinder head cover
- Spark plug
- Muffler

Remove the sprocket pressure plate [1] and bolt [2].

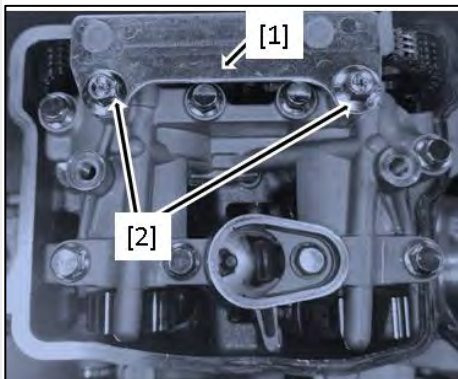

Verify Timing Position

Rotate the magneto flywheel nut [1] counterclockwise to align the timing mark "I" [2] on the flywheel with the timing groove [3] on the left front cover.

Check that the decompression valve flyweight [4] is in the position shown in the figure.

Check the timing mark "O" position [5] and index line position [6] of the camshaft sprocket as shown in the figure.

▲ **Note:**

- If the decompression valve flyweight is in the position shown in the figure, the piston is at the top dead center (TDC) of the compression stroke.
- If the position of the decompression valve flyweight is opposite, the piston is at TDC of the exhaust stroke. Rotate the crankshaft counterclockwise one full turn, and realign the timing mark on the magneto flywheel with the index line on the left front inspection cover bore.

Check that the timing mark "O" [5] on each camshaft sprocket is positioned at the top, the index line [6] on the intake and exhaust camshaft sprockets are aligned, and flush with the end face of the cylinder head cover.

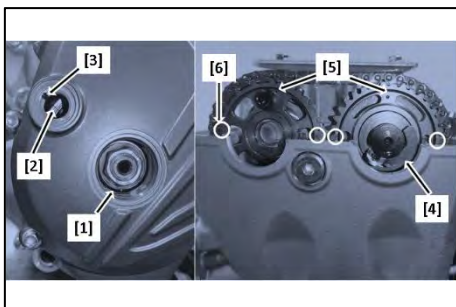

Locking tensioner rod

Remove the tensioner top bolt [1] and shim [2].

Rotate the tensioner clockwise to retract the tensioner rod and lock the tensioner [3].

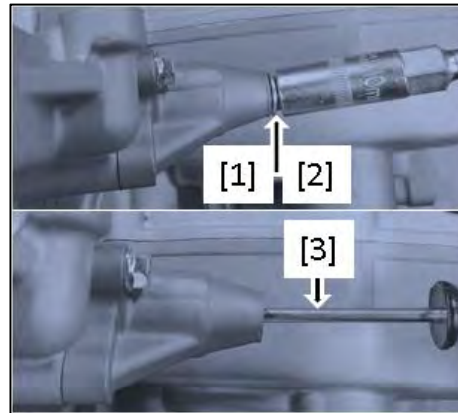

Disassemble camshaft bracket

First, cross inside and loosen the four bolts on the inner side of the cam bracket. Then cross again to the outside, loosen the 4 bolts on the outer periphery of the cam bracket, including 1 exhaust rocker arm shaft stopper bolt [3].

Remove the following components:

- Camshaft bracket bolts [1][2] and exhaust rocker arm shaft stopper bolts [3], totaling 8 pieces.
- One copper washer [4] for the spark plug bore must not be dropped.
- Remove the camshaft bracket [5].

▲ Note:

- When removing the camshaft bracket, ensure the spark plug bore seal ring [6] remains in the camshaft bracket mounting groove and does not fall out.
- Ensure the camshaft bracket dowel pin [7] is not loose or missing.
- Camshaft bracket bolt [1] M6×45, camshaft bracket bolt [2] M6×40.

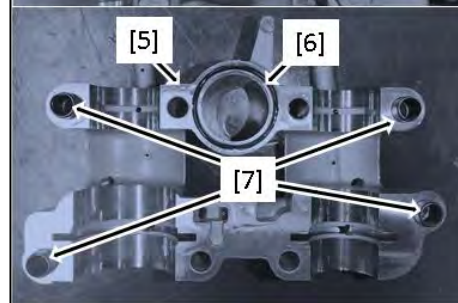
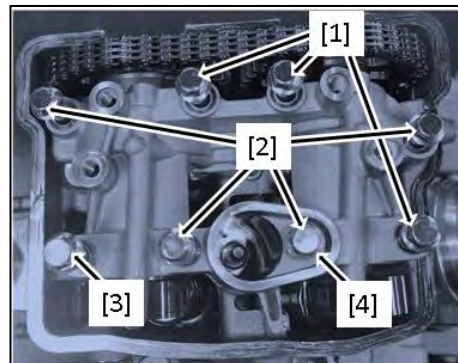

Remove the intake camshaft [1] and exhaust camshaft [2].

Use a steel wire to suspend the timing chain to prevent it from falling into the crankcase.

▲ Note:

- The timing chain must not fall into the crankcase.

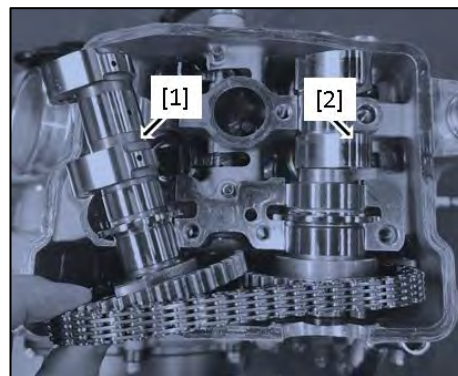

Lift the rocker arm [1].
Remove the valve shim [2].

▲ Note:

- Do not damage the rocker arm.
- Mark the valve washers that need adjustment to ensure the replacement shims are installed into the corresponding valve spring seats.
- The valve shim can be removed using tweezers and a magnet, and must not be dropped into the engine.

Match valve shim

Measure the thickness of the valve shim and record it.

Calculate the thickness of the new shims using the following equation:

$$A = (B - C) + D$$

A: New valve shim thickness

B: Recorded valve clearance value

C: Specified valve clearance value

D: Old valve shim thickness

▲ Note:

- Use a measuring instrument to measure the thickness of the removed valve shim.
- There are 69 shims available with different thicknesses, with an adjacent thickness difference of 0.025mm (ranging from 1.200-2.900mm).

If carbon deposition causes the calculated value to exceed 2.9mm, the valve should be inspected or the valve retainer reconditioned.

Place the matched valve shim into the corresponding valve spring seat groove.

Apply engine oil to the journals and cams of the intake and exhaust camshafts, then reinstall them into the camshaft installation grooves of the cylinder head.

As shown in the figure, install the exhaust camshaft with the decompression valve flyweight [1] facing downward.

▲ Note:

- The timing mark "O" of the intake camshaft and exhaust camshaft is located directly at the top.
- Align the timing marks on both timing sprockets, ensuring they are level with the mating surface of the cylinder head (see "Verify Timing Position").
- Ensure that the lobe tips of the intake camshaft [2] and exhaust camshaft [3] are facing upward.

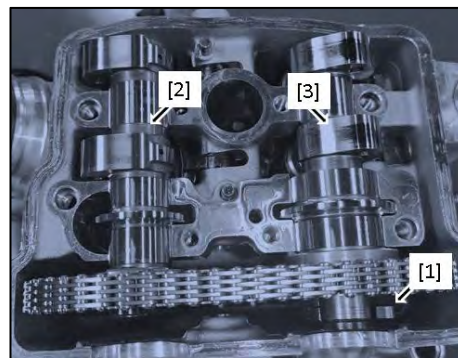
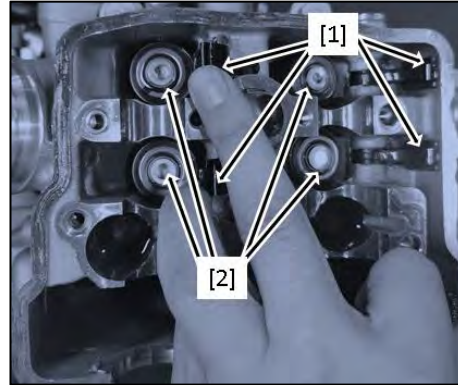

Reassembly after valve clearance adjustment

Replace the spark plug bore seal ring, apply engine oil, and install it in the mounting groove of the cam bracket.

▲ Note:

- Ensure the 4 dowel pins are properly seated in their bores.

Install the camshaft bracket.

Apply engine oil to the threads and mating surfaces of the camshaft bracket bolts and rocker arm shaft stop bolts.

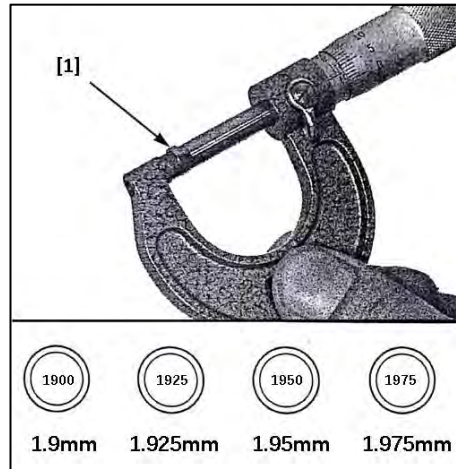

Refer to P25: Disassemble camshaft bracket, and P22: Verify Timing Position, then install the following components in reverse order:

Camshaft bracket bolts [1]M6×45 and [2]M6×40, rocker arm shaft stop bolt [3], and ensure that the exposed length inserted into the camshaft bracket is equivalent. Spark plug bore bolt with 1 copper washer[4].

Tighten the camshaft bracket bolts and rocker arm shaft stop bolts to the specified torque in the order of inner cross first, then outer cross.

Torque value: 13 N·m

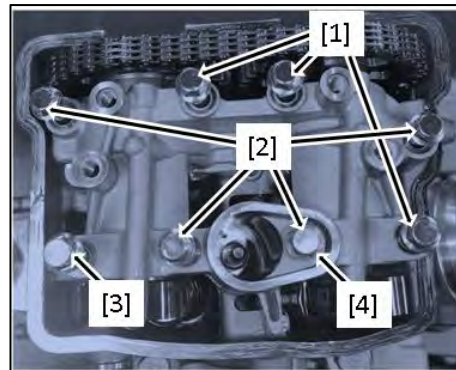

Refer to P25: **Reverse assembly of the tensioner rod** and restore the tensioner:

Release the lock the tensioner rod [1]. Install the top bolt [2] and new shim [3] of the tensioner.

Torque value: 10 N·m

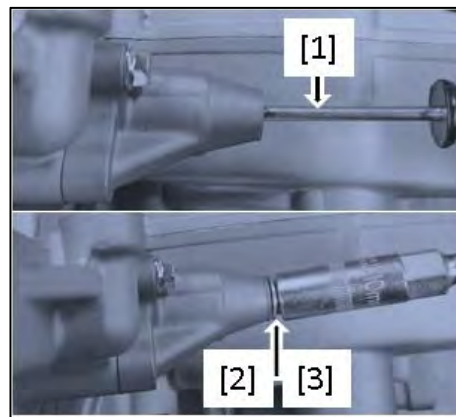

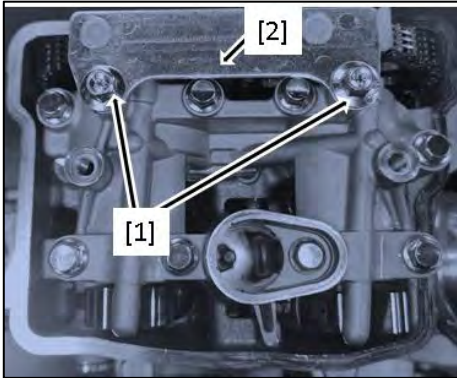

According to P8: Rotate and verify the timing position again to confirm that the engine magneto flywheel and camshaft are in the correct timing position.

Check and adjust the valve clearance to the specified value.

Intake valve clearance: 0.1 ± 0.03

Exhaust valve clearance: 0.2 ± 0.03

Install the timing sprocket pressure plate [1] and bolt [2].

▲ Note:

- Position the nylon block of the sprocket directly above the timing sprocket.

Tighten the sprocket pressure plate bolt to the specified torque.

Torque value: 10 N·m

Reinstall the following components:

- Muffler
- Spark plug
- Cylinder head cover
- Left trim cover
- Inspection cover

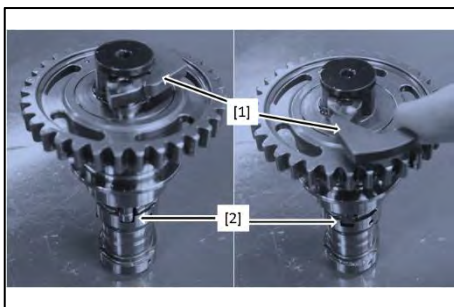

※ **Decompression system**

Remove the camshaft.

Check the operation of the decompression valve:

Use your finger to flip the decompression flyweight [1], and screw the semi-circular bulge [2] on the flyweight into the camshaft hole; release the flyweight, and let it return to its position.

The flyweight moves smoothly and flexibly without getting stuck, indicating that the decompression valve is operating normally.

If the decompression valve malfunctions to reset properly, disassemble, inspect, or replace the decompression system.

If the decompression valve operates normally, install the camshaft according to the "Verify Timing Position."

※ **Engine oil**
Check the oil level

Start the engine and warm it up at idle for 2-3 minutes.

Stop the engine, wait for 2-3 minutes, and place the motorcycle upright on a level surface.

Check the engine oil level through the sight window on the right crankcase cover.

If the oil level is below or near the lower index line [1], add the recommended engine oil to between the upper and lower index lines, but do not exceed the upper index line [2].

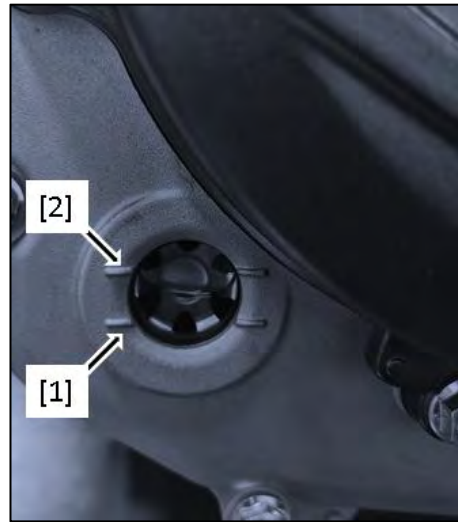

Change the engine oil

Start the engine and warm it up at idle for 2-3 minutes.

Stop the engine, wait for 3 minutes, and place the motorcycle upright on a level surface.

Place a container under the engine to catch the engine oil, then remove the engine oil drain bolt [1] and the sealing gasket [2].

Remove the engine oil plug [4] and O-ring.

Drain the engine oil.

Clean excess oil from the oil drain bolt and replace it with a new gasket.

After completing the oil drainage, install the engine oil drain bolt and tighten it to the specified torque.

Torque value: 23 N·m

Add the recommended engine oil to the specified oil level.

Recommended engine oil:

- SL10W-40
- API Quality Grade: SL or above (do not use the oil marked as energy-saving on the circular API service label).
- JASO T903 Standard: MA
- GB 11121-2006
- Viscosity: SAE10W-40

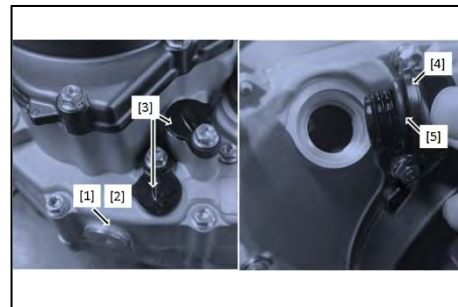

▲ **Note:**

The API classification specifies the quality and performance grade of engine oil. Use SL or higher grade engine oil, excluding those labeled as "Resource Saving" on the API service symbol.

Engine oil capacity:

- 1L: Remove the engine oil drain bolt and drain the engine oil.
- 1.1L: Remove the engine oil drain bolt to drain the engine oil, and replace it with a new oil fine filter.
- 1.2L: Remove the engine oil drain bolt to drain the engine oil, and replace it with a new oil fine filter and engine oil strainer [3].
- 1.35L: Assemble or install a new engine after disassembly.

Check the oil level again.

Confirm there are no oil leaks.

Check the O-ring [5] on the engine oil plug, and replace it with a new one if it is damaged or shows signs of deterioration.

Install the engine oil plug [4].

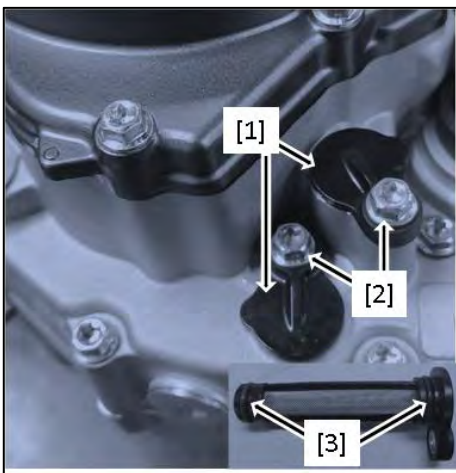
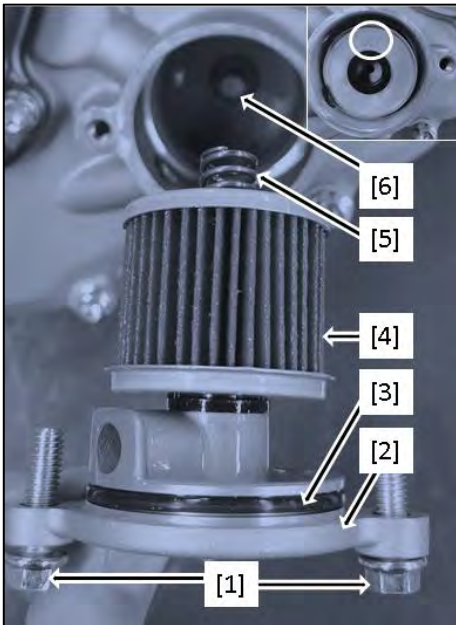

※ Engine oil filter

Check/replace the engine oil fine filter

Drain the engine oil.

Remove the following components:

- Engine oil fine filter cover bolt [1].
- Engine oil fine filter cover [2], O-ring [3] located in the sealing groove of the engine oil fine filter cover.
- Engine oil fine filter [4].
- Spring [5].

Apply engine oil to the contact surface of the oil fine filter spring, install the spring onto the positioning peg [6] in the oil filter chamber of the right crankcase cover, then install the oil fine filter with the "OUT" mark facing outward.

▲ Note:

- Installing the oil fine filter incorrectly can cause severe engine damage.

Replace the new O-ring and apply engine oil, then assembly it into the seal groove of the oil fine filter cover. Install the engine oil fine filter cover and bolts, then tighten the bolts.

Torque value: 10 N·m

Refer to P29: **Engine oil capacity** Fill the engine with the recommended oil.

Check/replace engine oil and oil strainer

Drain the engine oil.

Remove the following components:

- Engine oil strainer[1].
- Engine oil strainer fastening bolt [2].

If the engine oil strainer is severely damaged or blocked, replace the oil strainer.

Replace the new engine oil strainer and coat multi-purpose grease to the two O-rings [3] (if engine oil is applied, clean the excess oil after assembly) to avoid shear damage to the O-rings during assembly.

Fasten the engine oil strainer bolt.

Torque value: 10 N·m

※ **Inspection of Exhaust Pipe**

Notes

- Maintenance shall be carried out more frequently after the throttle is fully opened in the rain, the motorcycle is washed, or reversed. If a sediment layer can be seen in the transparent tube [2], it needs to be cleaned.

Remove the plug of the transparent air tube [3], drain the sediment into an appropriate container, and then reinstall the plug.

Inspect the crankcase vent hose [1]

Crack/damage → Replace.

Loose connection → Correct connection.

※ **Vehicle start (Choke)**

Always follow the correct startup procedure as described below.

Pulling out the knob aids in vehicle starting during cold weather.

Before starting the engine, check the engine oil and coolant levels.

See Page 29 for details

Engine cold start

1. Shift the transmission into neutral
2. If the temperature is 10°C or lower, fully pull out the damper knob before ignition.
3. Start the engine and let it warm up for 2-3 minutes. Push the choke knob all the way back to the closed position.

If the idle speed is unstable, slightly rotate the accelerator handle.

※ **Adjust front brake**

Adjustment

- Front hand brake lever position

The distance between the hand hand brake lever and the accelerator handle can be adjusted by rotating the adjusting bolt.

- a. Loosen the locking nut [1] of the hand brake lever adjusting bolt.
- b. Rotate the adjusting bolt [2] clockwise to increase the distance, and counterclockwise to decrease the distance.
- c. After adjustment, tighten the locking nut of the hand brake lever adjuster.
- d. Torque

6.0 N·m (0.6 kgf·m, 4.4 lbf·ft)

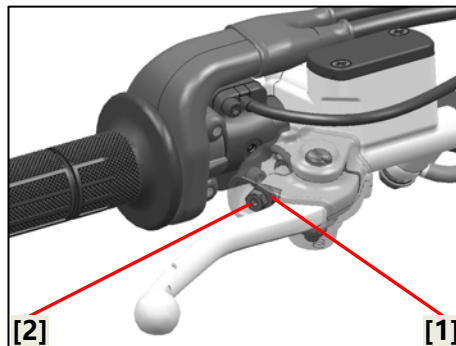
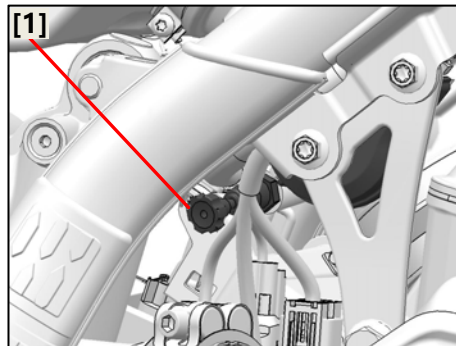
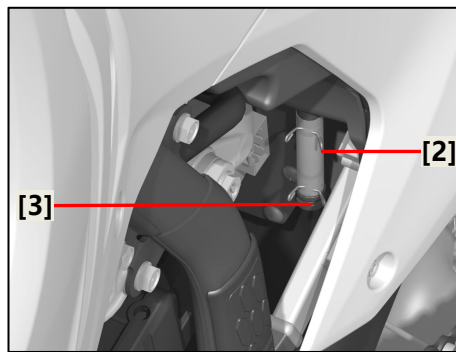
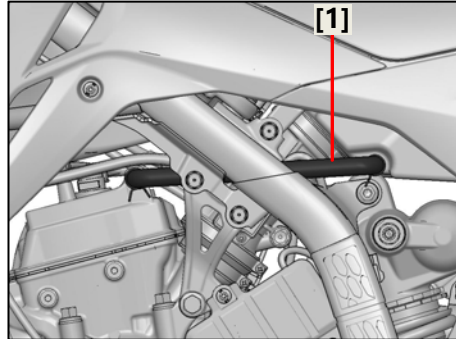

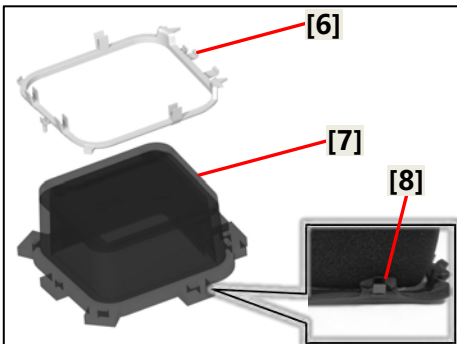
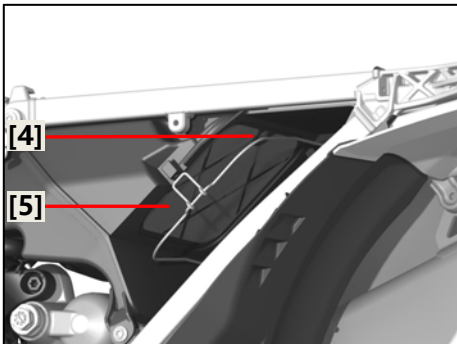
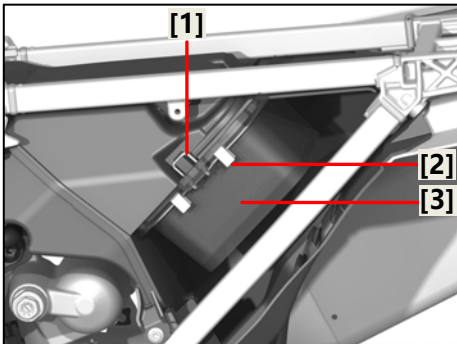

※ Cleaning and replacement of air filter sponge element

①. Sponge filter element and filter element bracket

Disassembly/installation

Disassemble the following parts:

- Release the retaining spring [1] of the sponge filter element;
- Sponge filter element [2] and element bracket [3];
- Remove the screws [4] fixing the metal filter screen;
- Take out the metal strainer [5].

The installation sequence is reversed from the removal sequence.

Note

- Remove the sponge filter element [7] from the filter element bracket [6].

Notes

- Be careful not to damage the sponge filter element [8].

Thoroughly clean the sponge filter element [1] in a cleaning solvent, and then clean it in hot water with detergent or soap solution.

Ensure that there is no dirt or dust in the air filter element. Clean it again if necessary. After cleaning, squeeze out the moisture from the air filter element and let it dry thoroughly.

Notes

- Since gasoline or low-flash-point solvents are highly flammable, it is prohibited to use them to clean the air filter sponge filter element.

Apply 50cm³ of KOVE foam air filter oil or equivalents to the inner side of the sponge filter element.

Put the air filter sponge filter element into a plastic bag and evenly apply the air filter oil with both hands.



- Do not use engine oil on the sponge filter element.

※ **Inspection and adjustment of clutch free play**

Inspect the clutch cable for twists or damage, and lubricate it if necessary.

Inspect the free play [a];

Free play: 10-20mm

Adjust it to the specified range if necessary.

Improper adjustment of the free play will cause premature wear of the clutch.

1. Fine-tune the clutch lever side

Usually, fine-tune at the adjustment knob at the end of the clutch cable. Turning the adjustment knob [1] in the (+) direction will increase the free play, and turning it in the (-) direction will reduce the free play.

(+) Increase free play;

(-) Decrease free play;

One notch of the adjustment knob [1] is 1/4 turn.

If the correct free play cannot be obtained even when the adjustment knob exceeds the adjustment limit, fully screw in and out the adjustment knob for 5 circles, and then make more adjustments on the left case side.

2. Conduct the major adjustment to bend pipe adjustment assembly

Use the bolt [1] at the lower clutch bend pipe adjustment assembly to conduct major adjustments. Loosen the locking nut [2] and turn the adjusting nut as needed to the specified free play. While holding the adjusting assembly bolt [1], tighten the 2 nuts [2]. Then put rubber grommets on the tightened nuts, and press the anti-detachment tab [3] of the clutch cable.

Torque:

Clutch cable adjusting nut

8.0 N·m (0.8 kgf·m, 6.0 lbf.ft)

3. Start the engine, pull the clutch handlebar, shift gears, and ensure that the engine does not stall and the motorcycle does not move unexpectedly. Gradually release the clutch handlebar and open the accelerator. The vehicle shall move smoothly to ensure that the clutch is working properly.

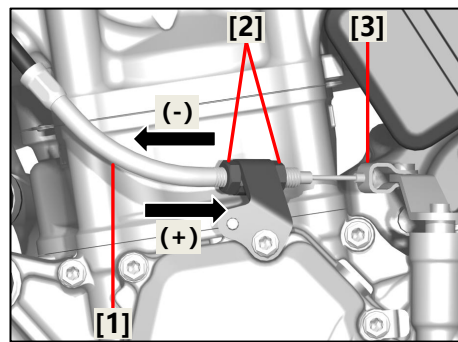
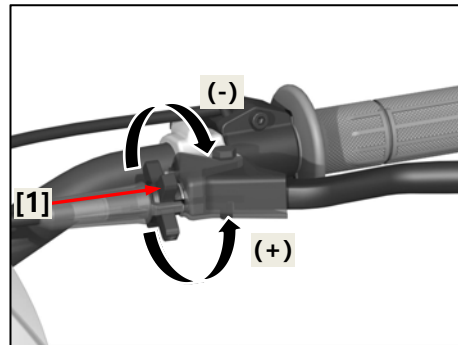
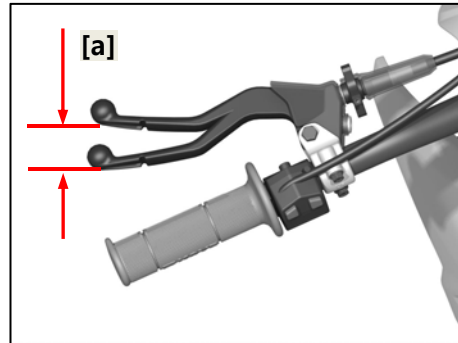

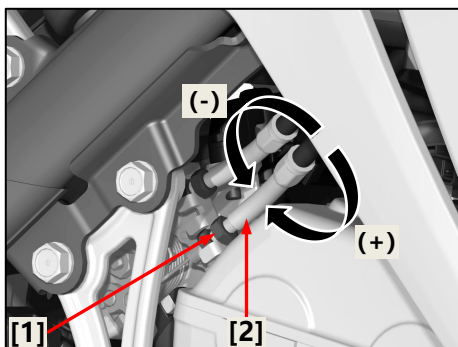
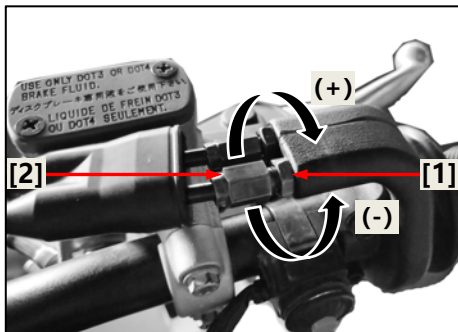
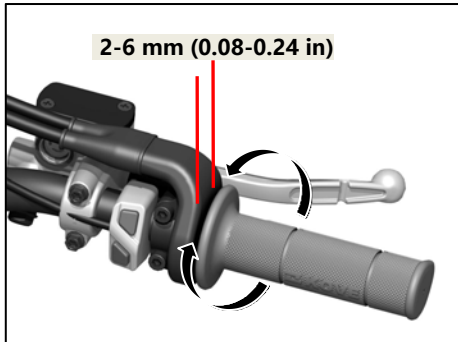

※ **Inspection and adjustment of accelerator free stroke**

Check whether the throttle cable is aged, damaged or kinked. Turn the accelerator handle and check that the throttle opens smoothly and closes automatically in any steering position.

If the accelerator handle does not rotate well, check that the cables are wired correctly, the accelerator is clean with recommended lubricant (engine oil or proper cable lubricant), and the accelerator drum rotates normally.

If Ok, but the throttle does not rotate well, replace the accelerator cable (oil inlet and oil return).

Measure the free play at the accelerator handle flange.

Free play: 2-6mm (0.08-0.24 in)

1. Fine-tune on the accelerator side

Loosen the lock nut [1] and turn the adjuster [2]. Turning the adjuster in the (-) direction will reduce the free play, and turning the adjuster in the (+) direction will increase the free play.

After adjustment, hold the adjuster and tighten the locking nut.

If the correct free play cannot be obtained despite turning the regulator to the end, turn it back in the (+) direction until it lightly touches the end, make one turn in the (-) direction, and then make more adjustments on the throttle side.

Nut [1] torque:

5.0 N·m (0.5 kgf·m, 4.0 lbf·ft)

2. Adequately adjust on the throttle side

Loosen the accelerator cable adjuster lock nut [1] and turn the adjuster [2] in the (-) direction to reduce the free clearance and in the (+) direction to increase the free clearance.

After the adjustment, hold the adjuster and tighten the locking nut of the inlet accelerator cable adjuster to the specified torque.

Torque:

4.0 N·m (0.4 kgf·m, 3.0 lbf·ft)



(The oil inlet and oil return cables are subjected to the same adjustment).

Notes

- Re-check whether the accelerator rotates smoothly or not.

※ **Lubrication of front brake handle**

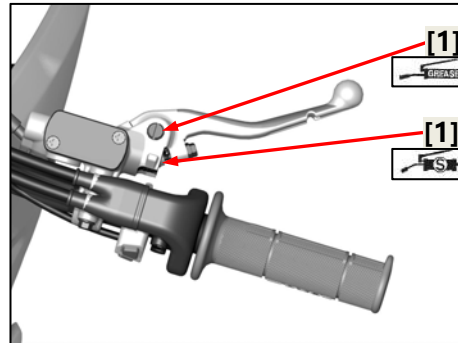

Apply lubrication to the pivot point of the handle and the contact areas of the metal parts [1].

	Recommended lubricating oil Use silicone grease
	Recommended lubricating oil Lithium-based multipurpose grease



※ **Lubrication of rear brake rocker arm**

Apply lubrication to the pivot point of the brake rocker arm and the contact areas of the metal parts [1].

	Recommended lubricating oil Lithium-based multipurpose grease
	Recommended lubricating oil Use silicone grease

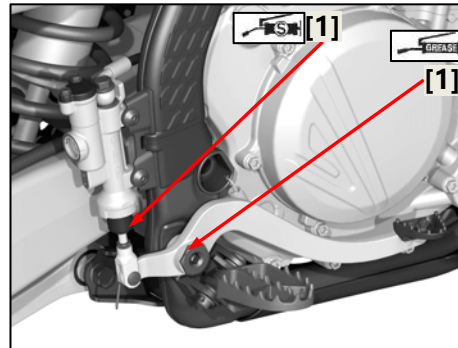

Lubrication of Clutch Handle

Apply lubrication to the pivot point of the handle and the contact areas of the metal parts [1].

	Recommended lubricating oil Lithium-based multipurpose grease
---	--

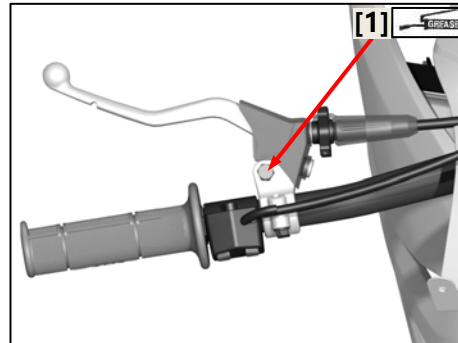

※ **Inspection and lubrication of pedal**

The anti-slip teeth of the pedal can be repaired by filing the grooves between the teeth with a triangular file. However, be aware that filing too much will reduce the lifespan of the sole. Only file the tips of the anti-slip teeth. Filing the grooves too deep will weaken the pedal. Make sure that the bolts can rotate freely and keep the cotter pins of the pivot pins in good condition. Apply lubrication to the pivot point of the pedal and the contact areas of the metal parts [1].

	Recommended lubricating oil Lithium-based multipurpose grease
---	--

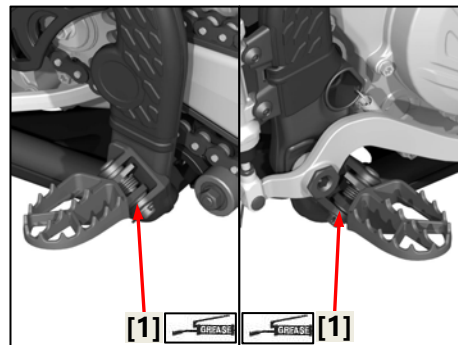

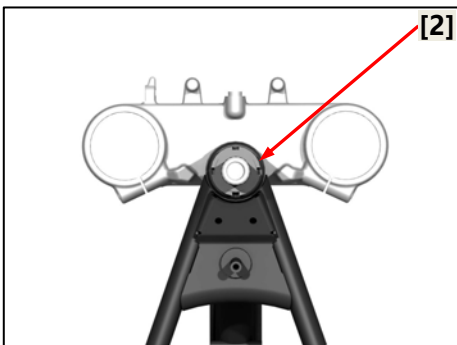
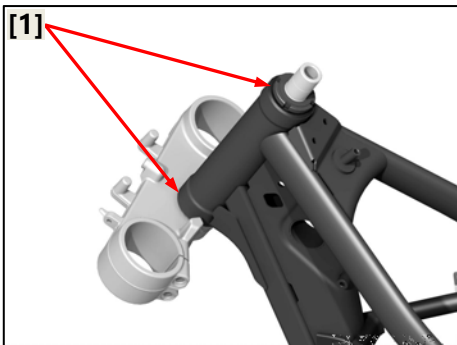

- Do not over-tighten the steering stem 4-slot nut.

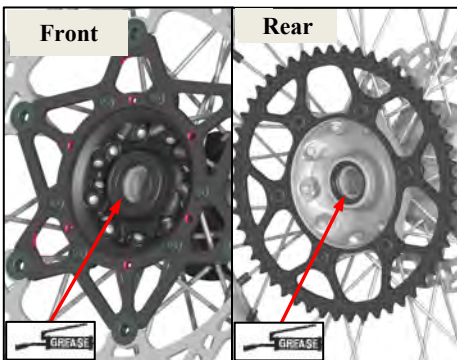

※ **Inspection and adjustment of steering head**

1. Stand the vehicle on a flat ground.



- Ensure that the vehicle is securely supported and not at risk of tipping over.

Note

- Place the vehicle on a suitable bracket to raise the front wheels.

2. Inspection:

Upper and lower dustproof washers [1];
Cracked/broken → Replace.

3. Inspection:

Steering head

Hold the front shock absorber bottom cylinder and gently shake the front fork.

Stuck/loose → Adjust steering head.

4. Disassemble:

Steering handle

Upper connecting plate

5. Adjustment:

Steering head

a. Loosen the steering stem 4-slot nut [2].

b. Use a torque wrench to lock the nut to the specified torque.

Note

- Make sure that the torque wrench is aligned perpendicular to the 4-slot nut socket.

Steering stem 4-slot nut (locking torque)

First torque to 40N·m, then loosen and torque to 10N·m, and finally back off by 1/4 turn.

c. After installing the upper bracket and handlebar, rotate the front shock absorber fully to both sides and check for any looseness or sticking in the steering head. In case of dry sticktion, remove the steering stem assembly from the lower bracket and inspect the upper and lower bearings.

※ **Inspection and lubrication of front and rear wheel bearing seal**

Regularly clean, inspect and lubricate oil seals, particularly when riding on wet, muddy, or dusty roads. Make sure all dustproof seals are in good condition. During installation, apply grease in the groove between the main and auxiliary lips of the oil seal.

Lubricate with high-temperature extreme pressure composite lithium grease (UNIVERSAL SU-T330Y or equivalent).

※ **Inspection and lubrication of steering head Bearing**

Regularly clean, inspect and lubricate steering head bearings, particularly when riding on wet, muddy, or dusty roads.
Lubricate with high-temperature extreme pressure composite lithium grease (UNIVERSAL SU-T330Y or equivalent).

	Recommended lubricating oil Lithium-based multipurpose grease
---	--

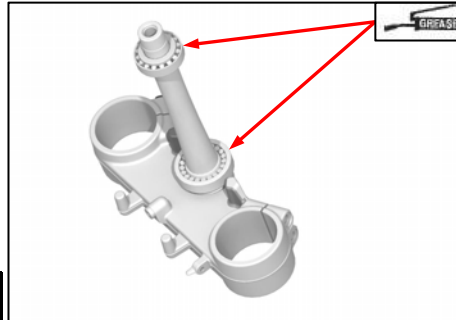

※ **Inspection and Lubrication of triangular cradle**

Clean, inspect and lubricate the triangular cradle bearing regularly. Make sure all dustproof seals are in good condition. During installation, apply grease in the groove between the main and auxiliary lips of the oil seal.
Lubricate with high-temperature extreme pressure composite lithium grease (UNIVERSAL SU-T330Y or equivalent).

	Recommended lubricating oil Lithium-based multipurpose grease
---	--

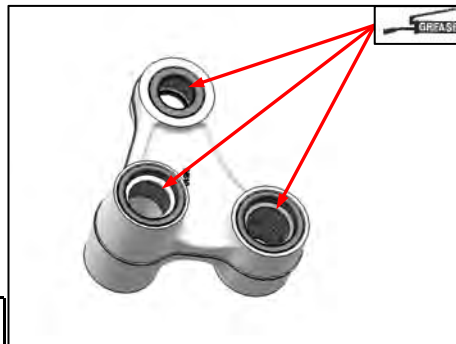

※ **Inspection and lubrication of swingarm axle**
Clean, inspect and lubricate the swingarm bearing regularly. Make sure all dustproof seals are in good condition. Apply the grease in the groove between the main and auxiliary lips of the oil seal. Lubricate with high-temperature extreme pressure composite lithium grease (UNIVERSAL SU-T330Y or equivalent). Do not attempt to weld or repair damaged swingarms, as welding can weaken the strength of the swingarms.

	Recommended lubricating oil Lithium-based multipurpose grease
---	--

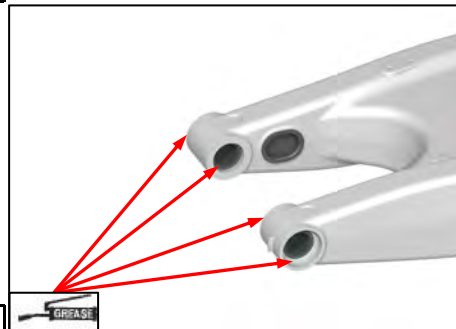

※ **Inspection and Lubrication of U-cradle**
Clean, inspect and lubricate the U-cradle bearing regularly. Make sure all dustproof seals are in good condition. Apply the grease in the groove between the main and auxiliary lips of the oil seal.
Lubricate with high-temperature extreme pressure composite lithium grease (UNIVERSAL SU-T330Y or equivalent).

	Recommended lubricating oil Lithium-based multipurpose grease
---	--

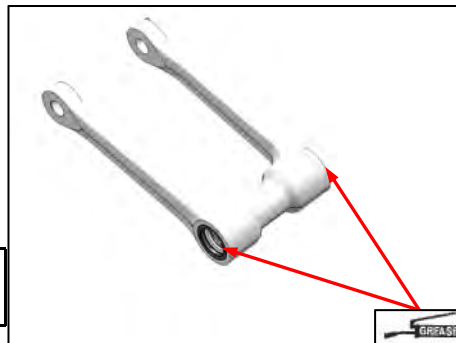

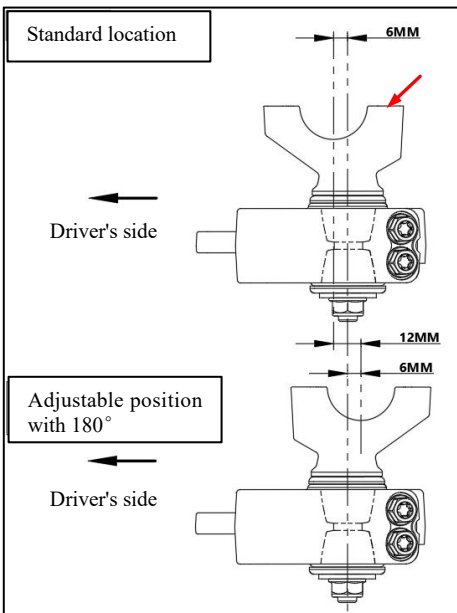
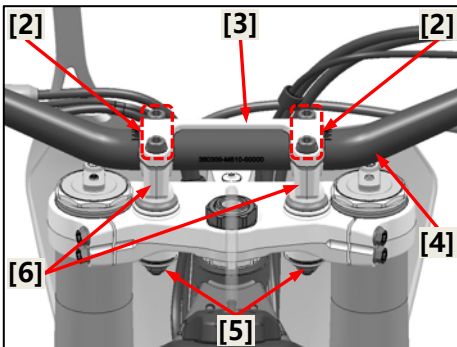

※ Adjustment of steering handlebar position

Notes

- The mounting position of the steering handlebar socket on this motorcycle can be adjusted, allowing a choice between forward and reverse installation.

The steps for adjusting and installing the steering handlebar position are as follows:

1. Disassembly

Steering handlebar chest protector[1];

Bolts [2];

Steering handlebar upper socket [3];

Temporarily remove the steering handlebar [4];

Lower socket bolt and flat gasket [5];

Lower socket [6].

2. Adjustment

After adjusting the distance of the lower socket on the steering handlebar, install the steering handlebar in the optional position.

3. Installation

The installation sequence is reversed from the removal sequence.

Torque:

Steering handlebar and upper/lower socket

22 N·m (2.2 kgf·m, 16 lbf·ft)

Upper connecting plate and lower double-threaded stud (self-locking nut)

22 N·m (2.2 kgf·m, 16 lbf·ft)

The handlebar distance position can be adjusted by changing the direction of the lower socket [1].

Notes

- The steering handlebar lower socket is offset by 6 mm from the centerline of the socket. The steering handlebar socket position can be set with an offset distance of 12 mm, positioned behind the standard location.

※ **Inspection of front shock absorber**

1. Stand the vehicle on a flat ground.



- Support the vehicle firmly so as not to turn over.

2. Inspection:

- Front fork tube

Damage/scratch → Replace.

- Front shock absorber bottom cylinder

Oil leaks between fork tube and outer cylinder
→ Replace oil seal.

3. Keep the vehicle upright and engage the front brake.

4. Inspection:

- Front shock absorber actuation

Press down firmly on the handlebar several times to check for smooth rebound of the front shock absorber.

Unsmooth movement → Maintenance.

See "Front Wheels, Suspension, Steering" on page 127 for details.



※ **Inspection of rear shock absorber**



1. Stand the vehicle on a flat ground.

- Support the vehicle firmly so as not to turn over.

2. Inspection:

- Rear shock absorber inner rod

Bend/damage → Replace rear shock absorber.

- Rear shock absorber

Oil leaks → Replace rear shock absorber.

- Spring

Damage/wear → Replace rear shock absorber.

- Size of Bolts

Bend/damage/wear → Replace.

3. Inspection:

- Rear shock absorber actuation

Press down firmly on the rear of the vehicle seat cushion several times to check for smooth rebound of the rear shock absorber.

Irregular movement → Adjust.

See "Regular Maintenance and Adjustment" on page 17 for details.



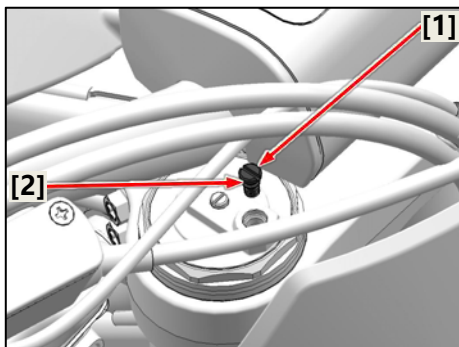
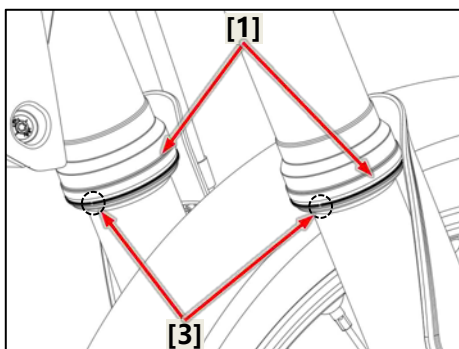
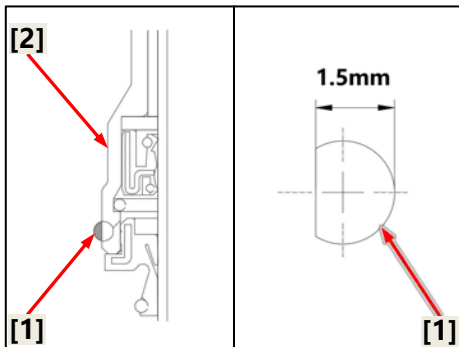

※ Inspection of front shock absorber wear ring

Check the operation of the front shock absorber by operating the front brake and compressing the front shock absorber several times.

Check the entire front shock absorber assembly for signs of leakage, damage, or loose fasteners. Check if the decorative protector and the dustproof seal ring of the front shock absorber are clean, free of dirt or dust. Remove the dirt or dust accumulated at the bottom of the front shock absorber seal.

Check the wear ring [1] for wear or damage. If the wear ring is less than 1.5 mm or flush with the front fork tube [2], replace the wear ring.

Ensure that the end clearance [3] of the wear ring faces backward.

※ Adjustment of air pressure inside front shock absorber

The shock absorber generates internal air pressure during operation, which acts like a progressive resistance, subsequently affecting the performance of the shock absorber. So as the race conducts, the front shock absorber on this motorcycle will become stiff.

After the race or practice, it is necessary to release the accumulated air pressure in the front shock absorber in a timely manner.

Ensure the front shock absorber is fully extended, the front wheel is off the ground, and completely loosen the front shock absorber bleed bolt [1]. Check if the O-ring [2] of the bleed bolt is damaged, and replace it if necessary. Apply the recommended grease to the O-ring.

Install and tighten the front bleed bolt to the specified torque.

1.3 N·m (0.1 kgf·m, 1.0 lbf·ft)

※ **Front shock absorber settings and adjustments**

1. Compression Damping Adjustment

The adjustment of the compression damping affects the speed at which the front shock absorber compresses. The front shock absorber features 22 stages of compression damping. Each segment is a quarter turn. Turning the compression damping adjustment bolt one full turn will rotate the adjuster by 4 segments.

The compression damping increases when the adjuster is rotated clockwise (H), and the compression damping decreases when the adjuster is rotated counterclockwise (S).

Set standard compression damping:

1. Clockwise rotate the compression damping adjuster until it cannot be rotated.
2. Rotate the adjusting bolt in a counterclockwise direction (lightly). The standard compression damping is to rotate 10 segments counterclockwise from the hardest position (the position where a click sound is heard).

You can make adjustments based on your weight and riding conditions. Ensure that the adjustment bolt stops at the click position and both ends are set to the same level after each adjustment.

2. Rebound damping adjustment

The adjustment of rebound damping will affect the rebound speed of the front shock absorber. The front shock absorber features 22 stages of rebound damping. Each segment is a quarter turn. Rotating the rebound damping adjustment bolt one full turn will advance the adjuster by 4 stages.

Turn the adjustment bolt clockwise to increase the rebound damping (hard), and turn it counterclockwise to decrease the rebound damping (soft).

Set the standard rebound damping:

1. Rotate the rebound damping adjustment bolt clockwise until it can no longer be turned.
2. Rotate the adjusting bolt in a counterclockwise direction (lightly). The standard rebound damping is to rotate 10 segments counterclockwise from the hardest position (the position where a click sound is heard).

You can make adjustments based on your weight and riding conditions. Ensure that the adjustment bolt stops at the click position and both ends are set to the same level after each adjustment.

Notes

- Gently rotate the adjusting bolt to prevent damage to the shock absorber.
- When adjusting rebound damping or rebound damping, be sure to use the appropriate size of the tool to avoid damage to the device.
- Do not continue to rotate the adjusting bolt after it has been turned to the bottom, otherwise it may damage the adjusting device. The adjusting torque shall not exceed 0.5N·m.

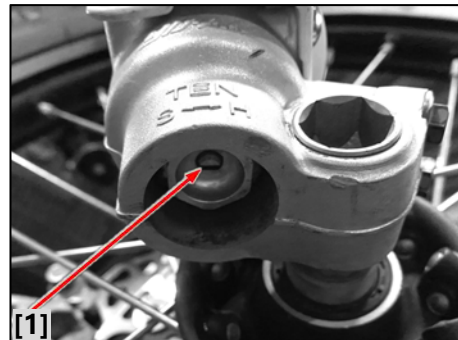
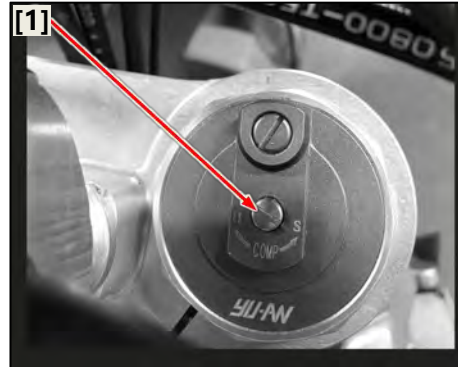

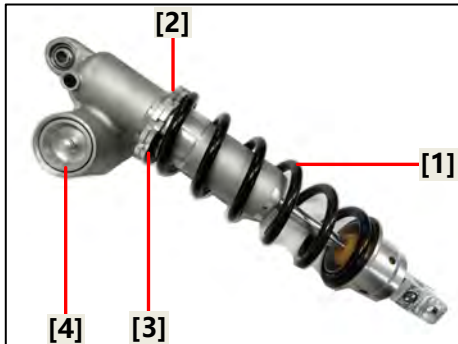

※ Rear shock absorber settings and adjustments



- The rear shock absorber includes a shock absorber gas cylinder [4] containing high pressure nitrogen. Do not attempt to remove, repair or dispose of the device. Piercing or exposure to flame may also cause an explosion, causing serious injury. Repair or disposal shall be completed by special repair shop.

Spring preload adjustment

Adjustment method:

1. Securely support your motorcycle with a maintenance bracket or a crane and lift the rear wheels off the ground.
2. Check whether the spring preload is in the standard length. (228mm)
3. Loosen the shock absorber spring locking nut [2] and rotate the adjusting nut. The spring [1] length will change by 1.5 mm for each turn of the adjusting nut.
4. Make corresponding adjustments as needed.
5. After the adjustment is completed, hold the adjusting nut [2] and tighten the shock absorber spring locking nut [3].

Torque: 44 N·m

Increase spring preload:

Loosen the shock absorber spring locking nut [2] with a special tool, rotate the adjusting nut [3], and shorten the spring [1] length. The minimum length shall not be less than 220mm.

Reduce spring preload:

Loosen the shock absorber spring locking nut [2] with a special tool, rotate the adjusting nut [3], and increase the spring [1] length. The minimum length shall not be higher than 235mm.

Each turn of the adjusting nut will change the spring length and spring preload.

Rear shock compression damping adjustment

The compression damping can be adjusted separately for the bolt to conduct high-speed compression damping and low-speed compression damping. You can adjust it according to your weight and riding conditions.

1. High-speed compression damping adjustment

The high-speed compression damping adjuster is effective when rebound damping adjustment is needed for high-speed operation. High-speed damping can be adjusted by rotating the hexagonal part of the compression damping adjuster. The high-speed compression damping adjuster is incremented in 1/4-turn steps. Ensure the high-speed adjuster is securely in the braking position, not between positions.

Adjust to the standard position:

1. Turn the adjusting bolt [1] clockwise (H) until it no longer rotates (hardest position).
2. Rotate the adjusting bolt [1] counterclockwise for 2 turns from the hardest position.

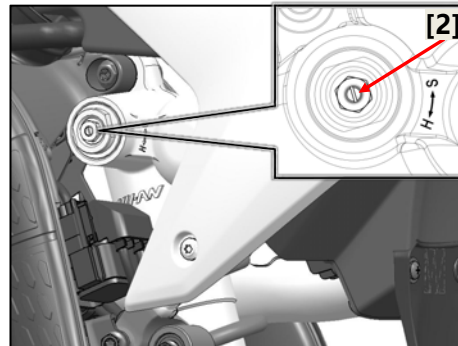
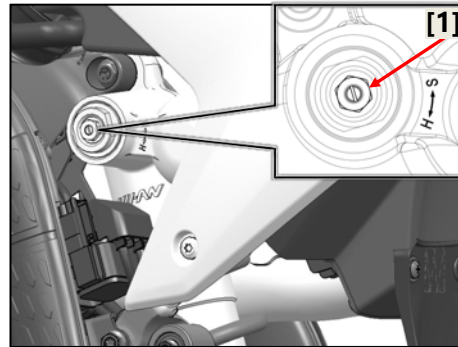

2. Low-speed compression damping adjustment

When damping adjustment is required at a relatively low speed, the low-speed compression damping adjusting bolt should be used. The low-speed compression damping adjuster has 16 segments, each with a 1/4 turn.

Turning clockwise (H) increases damping and makes the shock absorber stiffer, while rotating counterclockwise (S) increases damping and makes the shock absorber softer.

Adjust to the standard position:

1. Rotate the adjusting bolt [2] clockwise (H) until it no longer turns (maximum hardness).
2. Rotate the adjusting bolt [2] for 8 segments counterclockwise from the hardest position (until a click sound is heard).

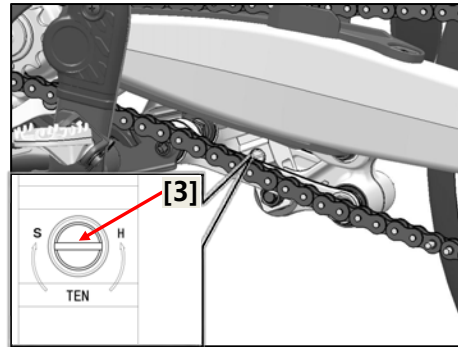

3. Rebound damping adjustment

The rebound damping adjusting bolt is located at the left lower end of the rear shock absorber with 24 segments in total. The rebound damping increases when the adjuster is rotated clockwise (H), and the rebound damping decreases when the adjuster is rotated counterclockwise (S).

Set the standard rebound damping:

1. Rotate the rebound damping adjusting bolt (H) clockwise until it stops rotating.
2. Turn the adjusting bolt counterclockwise (S, lighter) to set the standard rebound damping by rotating it 8 segments from the hardest position, stopping at the click sound.

Notes

- Gently rotate the adjusting bolt to prevent damage to the shock absorber.
- When adjusting rebound damping or rebound damping, be sure to use the appropriate size of the tool to avoid damage to the device.
- Do not continue to rotate the adjusting bolt after it has been turned to the bottom, otherwise it may damage the adjusting device. The adjusting torque shall not exceed 0.5N·m.

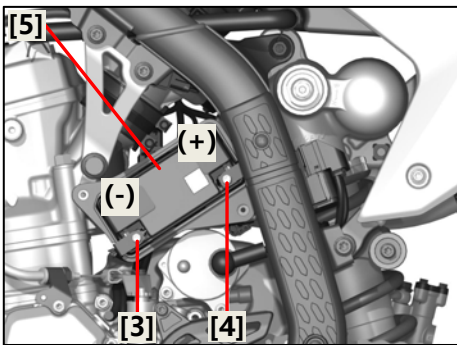
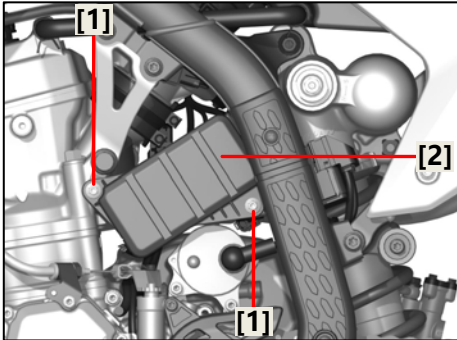

Torque:
 Battery box cover mounting bolts
 5.0 N·m (0.5 kgf·m, 3.7 lbf·ft)
 Battery terminal mounting screw
 5.0 N·m (0.5 kgf·m, 3.7 lbf·ft)

Battery specification:

Battery model: HJ12-FPZ (lithium battery)
 Full charging voltage: > 13.2V
 Required charging voltage: < 12.8V
 Charging current: standard 1.2A, max. 12.0A
 Operating temperature: -20°C - 60°C
 Battery capacity: 12V/2.3Ah
 Overall dimension: Length x Width x Height: 112x49x85(±1mm)

※ **Battery Inspection and Charging**



- The negative wire must be disconnected before disassembling the battery, otherwise the battery will be short-circuited.

Disassembly/installation

Disassemble the following parts:

- After the vehicle get stall;
- Step screw [1];
- Battery box cover [2];
- Disconnect the negative battery electrode (-) cable with screw [3].
- Disconnects the positive (+) cable with screw [4];
- Remove the battery rubber grommet [5].

Note

- Battery is designed with over-charge protection, and the voltage for over-charge protection is 15.3V-15.9V.

Charging

- Turn off the vehicle and disconnect the positive and negative electrodes of the battery from the battery terminals.
- Remove battery;
- Connect the charger to the battery, turn on the charger

When the charging is completed, turn off the charger, and unplug it from the battery;

Notes

- If the vehicle is not in use, recharge its battery every 3 months.

Check charging voltage

The battery must function properly and be fully charged.

Start the vehicle for a voltage test;

Measuring point positive (+), measuring point grounding (-).

Notes

- When measuring the battery voltage after charging, it shall be maintained for at least 30 minutes, otherwise accurate results cannot be obtained due to battery voltage fluctuations after charging.

Charging voltage	
5000rpm	13.9-14.9 V

Frame, Body Trim, Exhaust System

Section 1 Maintenance instructions	46
Section 2 Body trim position	47
Section 3 Seat cushion assembly	48
Section 4 Battery box cover	48
Section 5 Front fuel tank trims - left and right	49
Section 6 Vehicle body - left and right	49
Section 7 Rear tailgate	50
Section 8 Tailpipe plug	50
Section 9 Front windshield	50
Section 10 Front fender	51
Section 11 Front shock absorber trims (left and right), oil pipe pressure plate	51
Section 12 Engine lower protector	52
Section 13 Engine front sprocket cover and chain pressure plate	52
Section 14 Rear splash guard	52
Section 15 Chain guide/chain clip	53
Section 16 Guide sprocket and guide chain slider	54
Section 17 Frame trim-left and right	54
Section 18 Pedal assembly/oil pipe clamp/gear shift assembly	55
Section 19 Handle switch-left and right	56
Section 20 Engine control unit (ECU) / split-type ignition coil	57
Section 21 Regulating rectifier/starting relay/main relay	58
Section 22 Battery box	59
Section 23 Muffler assembly	60
Section 24 Subframe and air filter assembly	61
Section 25 Rear fender	61
Section 26 Frame serial number and engine number	62

Maintenance Instructions

Overview:

- This section describes the disassembly and reassembly of body trim and exhaust system;
- For disassembly, mark and store the mounting fasteners to ensure that they are reinstalled in their original positions;
- For bonnet installation, ensure that the matching areas are correctly aligned before tightening the fasteners;
- After removing the exhaust system, be sure to use new washers;
- When installing the exhaust system, loosen all fasteners first. Be sure to tighten the exhaust pipe joint nut before tightening the mounting bolts;
- Be sure to check the exhaust system for leaks after installation.

Troubleshooting

- Excessive exhaust noise.
- Exhaust system damage;
- Inadequate exhaust gas leak performance;
- Exhaust system deformation;
- Exhaust pipe blockage.

Body Trim Position

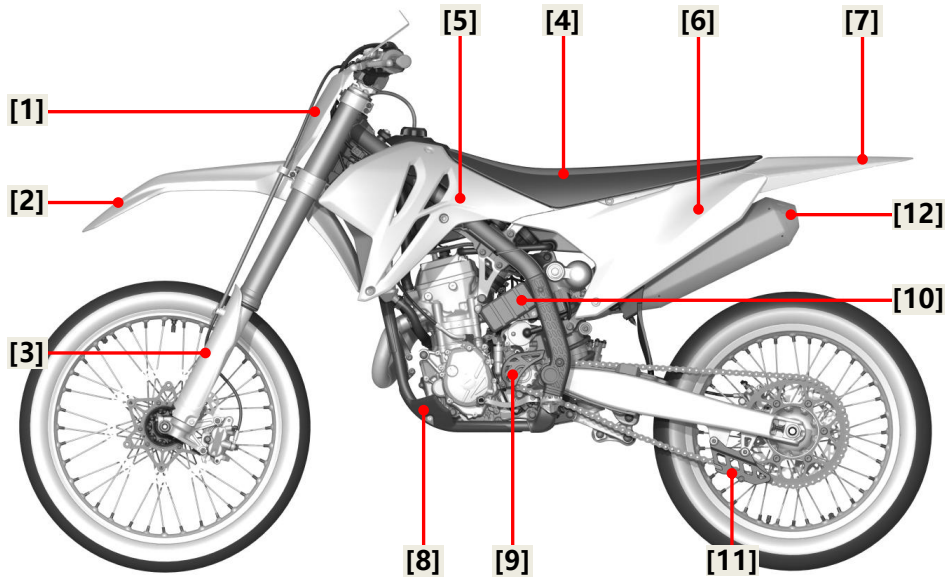

(1) Windshield (number plate)	(5) Fuel tank front trim	(9) Engine front sprocket cover
(2) Front fender	(6) Vehicle body (left and right)	(10) Battery box cover
(3) Front shock absorber trim (left and right)	(7) Rear tailgate	(11) Chain guide assembly
(4) Seat cushion assembly	(8) Engine lower protector	(12) Muffler/exhaust pipe

After the motorcycle is powered off, carry out disassembly in this order below:

Seat cushion assembly → Front fuel tank trim (left and right) → Vehicle body (left and right) → Tailgate → Front windshield → Front fender → Front shock absorber trim (left and right) → Engine lower protector → Engine front sprocket cover → Gear shift arm assembly → Front brake assembly → Front wheel assembly → Front shock absorber → Steering handlebar (assembly) → Upper connecting plate → Lower connecting plate and steering stem assembly → Rear wheel assembly → Rear brake assembly → Rear brake pedal assembly → Suspension components → Drive chain → Rear shock absorber → Swingarm → Chain guide assembly → Rear splash guard → Muffler/exhaust pipe assembly → Radiator hose → Radiator (left and right) → OBD diagnostic interface → Fuel tank assembly → ECU control unit → Exhaust pipe → Regulating rectifier → Subframe → Air filter assembly → Full vehicle wiring harness and electrical components → Throttle valve body assembly → Battery box → Engine assembly.

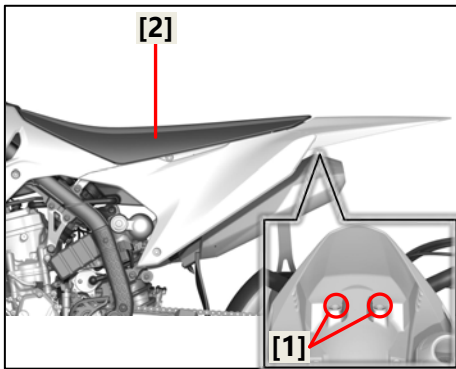

※ **Seat cushion assembly**

Disassembly/installation

Disassemble the following parts:

- Remove 2 hexalobular pan head bolts [1];
- Press down and then push back to remove the seat cushion [2].

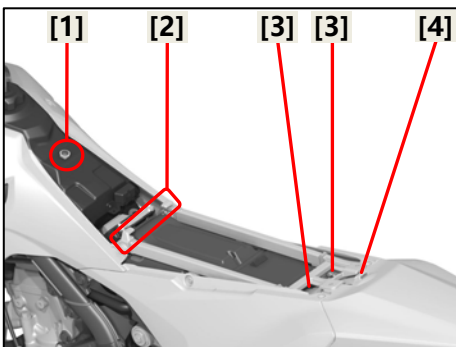

Install the following components:

Insert the seat cushion's bottom rod into frames [1], [2], [3], and [4] in sequence, then install the rear tailgate cushion locking bolt.

Torque :

Seat cushion assembly and rear tailgate
8.0 N·m (0.8 kgf·m, 6.0 lbf.ft)

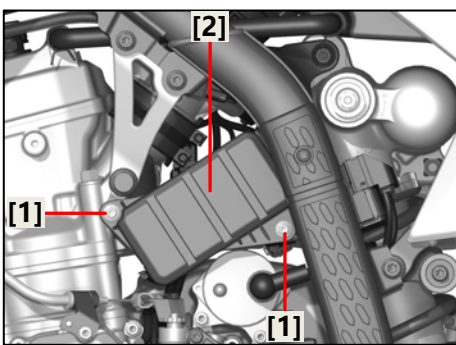

※ **Battery box cover**

Disassembly/installation

Disassemble the following parts:

- Hexalobular pan head bolt[1];
- Battery box cover [2].

The installation sequence is reversed from the removal sequence.

Torque :

Battery box cover mounting bolts
5.0 N·m (0.5 kgf·m, 3.7 lbf.ft)

※ **Front tank trim (left and right)**

Disassembly/installation

Disassemble the following parts:

- Hexalobular pan head bolt [1], [2], [3], [4];
- Front fuel tank trim - left [5].

The installation sequence is reversed from the removal sequence.

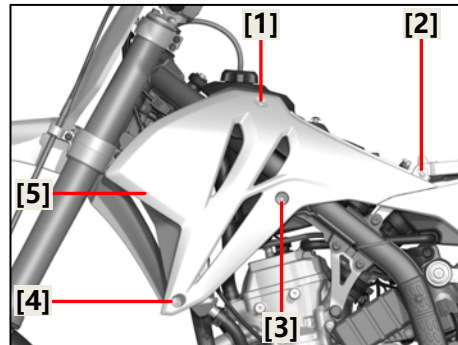

Notes

- Front fuel tank trim - right: The disassembly and installation method are the same as above.

Torque:

Front fuel tank trim - left and right with fuel tank

Front fuel tank trim - left and right with subframe

Front fuel tank trim - left and right with frame

Front fuel tank trim - left and right with radiator

5.0 N·m (0.5 kgf·m, 3.7 lbf·ft)

※ **Vehicle body (left and right)**

Disassembly/installation

Disassemble the following parts:

- Hexalobular pan head bolts [1], [2], [3];
- Vehicle body - right [4].

The installation sequence is reversed from the removal sequence.

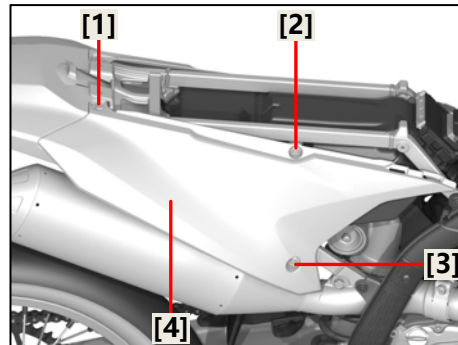

Notes

- Vehicle body - left: The disassembly and installation method is the same as above.

Torque:

Vehicle body - left and right with subframe

8.0 N·m (0.8 kgf·m, 6.0 lbf.ft)

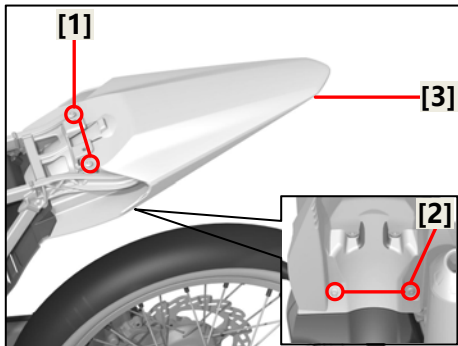

※ **Rear tailgate**

Disassembly/installation

Disassemble the following parts:

- Hexalobular pan head step screw [1];
- Hexalobular pan head step screw[2];
- Rear tailgate [3].

The installation sequence is reversed from the removal sequence.

Torque :

Rear tailgate (lower) and subframe

Rear tailgate (upper) and subframe

8.0 N·m (0.8 kgf·m, 6.0 lbf.ft)

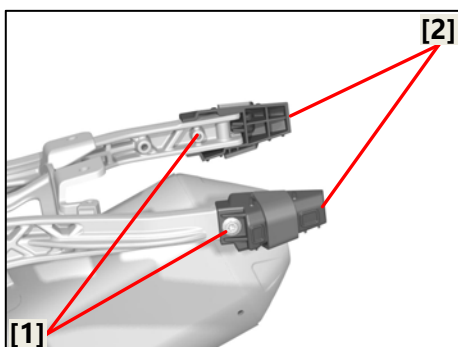

※ **Tailpipe plug**

Disassembly/installation

Disassemble the following parts:

- Hexalobular pan head step screw[1];
- Subframe tailpipe plug[2].

The installation sequence is reversed from the removal sequence.

Torque :

Rear tailgate plug and subframe

5.0 N·m (0.5 kgf·m, 3.7 lbf.ft)

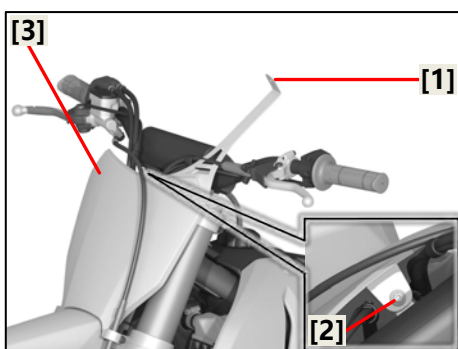

※ **Windshield (number plate)**

Disassembly/installation

Disassemble the following parts:

- Remove the strap[1] from the back of the windshield;
- Hexalobular pan head step screw[2];
- Front windshield[3].

The installation sequence is reversed from the removal sequence.

Torque :

Front windshield and upper connecting plate

5.0 N·m (0.5 kgf·m, 3.7 lbf.ft)

※ **Front fender**

Disassembly/installation

Disassemble the following parts:

- Bolt, flat gasket, flanged bushing [1];
- Front fender [2].

The installation sequence is reversed from the removal sequence.

Torque:

Front fender and lower connecting plate

12 N·m (1.2 kgf·m, 9.0 lbf·ft)

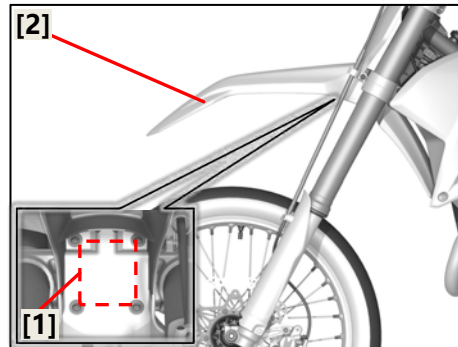

※ **Front shock absorber trims (left and right), oil pipe pressure plate**

1. Oil pipe pressure plate

Disassembly/installation

Disassemble the following parts:

- Screw [1]
- Remove the pressure plate [2].

The installation sequence is reversed from the removal sequence.

Torque:

Brake hose pressure plate mounting screw

8.0 N·m (0.8 kgf·m, 6.0 lbf.ft)

2. Front shock absorber trim

Disassembly/installation

Disassemble the following parts:

- Hexalobular pan head step screw [1],[2];
- Front shock absorber trim [3], [4].

The installation sequence is reversed from the removal sequence.

Torque:

Mounting bolts of front shock absorber trims

8.0 N·m (0.8 kgf·m, 6.0 lbf.ft)

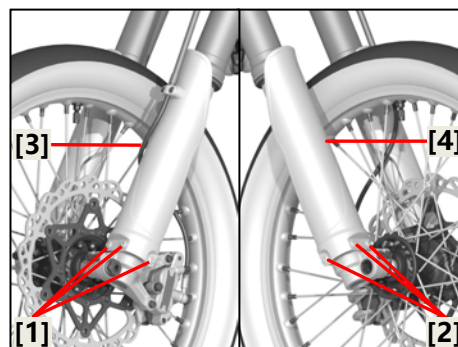
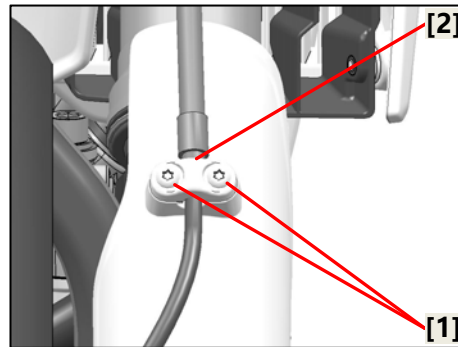

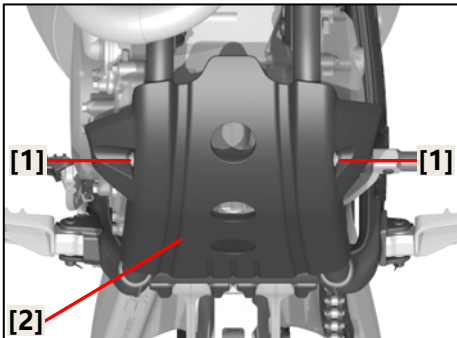

※ **Engine lower protector**

Disassembly/installation

Disassemble the following parts:

- Hexalobular pan head bolt [1];
- Engine lower protector [2].

The installation sequence is reversed from the removal sequence.

Torque:

Engine lower protector mounting screws
5.0 N·m (0.5 kgf·m, 3.7 lbf·ft)

※ **Engine front sprocket cover and chain pressure plate**

Disassembly/installation

Disassemble the following parts:

- Bolt [1];
- Front sprocket cover and chain baffle [2].

The installation sequence is reversed from the removal sequence.

Torque:

Front sprocket cover mounting bolt
10 N·m (1.0 kgf·m, 7.0 lbf·ft)

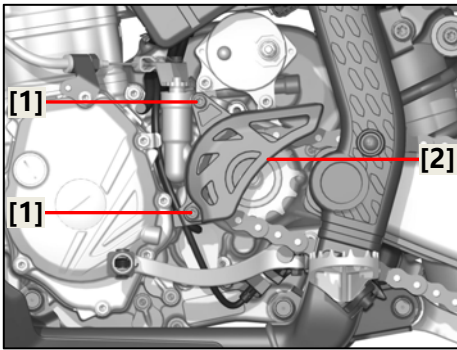

※ **Rear splash guard**

Disassembly/installation

Disassemble the following parts:

- Self-tapping screw ST4.8x15 [1];
- Rear splash guard.

The installation sequence is reversed from the removal sequence.

Torque:

Rear splash guard self-tapping screw
2.0 N·m (0.2 kgf·m, 1.5 lbf·ft)

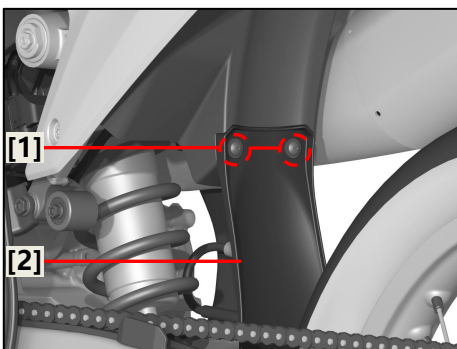

Note: Replace the rear splash guard promptly if it is damaged or cracked.

※ **Chain guide**

Disassembly/installation

Disassemble the following parts:

- Guide slider wear block mounting bolt [1];
- Guide slider wear block [2];
- Bolt [3];
- Chain guide [4].

The installation sequence is reversed from the removal sequence.

Torque:

Chain guide mounting bolt

10 N·m (1.0 kgf·m, 7.0 lbf·ft)

Guide slider wear block mounting bolt

5.0 N·m (0.5 kgf·m, 3.7 lbf·ft)

Check if the chain guide [1] is deformed or damaged.

Notes

- If the frame of the chain guide box is deformed, it may hit the drive chain, causing the drive chain to fall off, wear or generate noise.
- Check if the wear block [2] of the chain slider has wear.
- If the wear block of the guide chain wears down to the position at the bottom [3], replace the wear block of the drive chain guide.

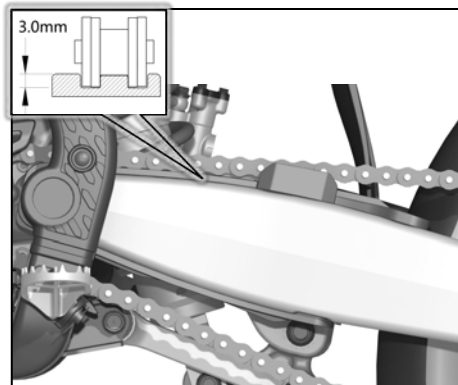
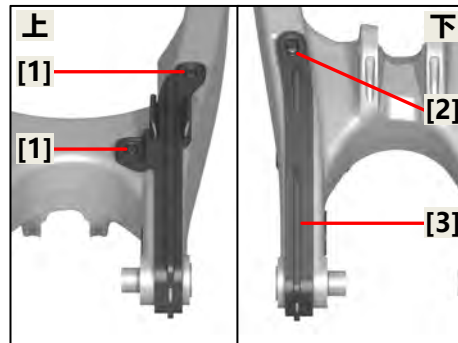
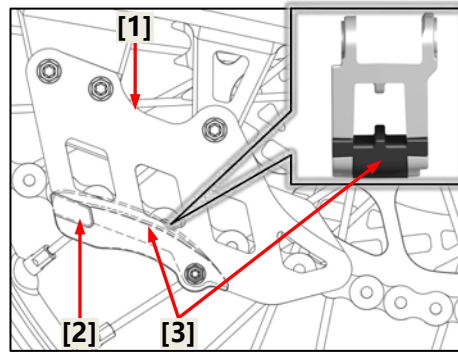
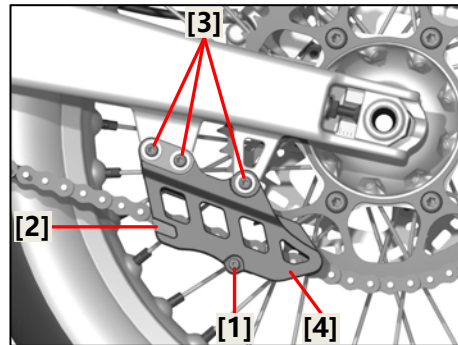

※ **Chain guard clip**

Disassembly/installation

Disassemble the following parts:

- Screw and pressure plate [1];
- Screw and pressure plate [2];
- Chain clip [3].

The installation sequence is reversed from the removal sequence.

Torque:

Chain clip mounting screw

8.0 N·m (0.8 kgf·m, 6.0 lbf.ft)

Inspect the chain clip for excessive wear.

Wear limit not exceed:

Top: 3mm

Bottom: 2mm

Notes

- Please replace the chain clip in time if it exceeds the wear limit.
- If the chain clip reaches its wear limit or is damaged, it can lead to damage in the swingarm or drive chain.

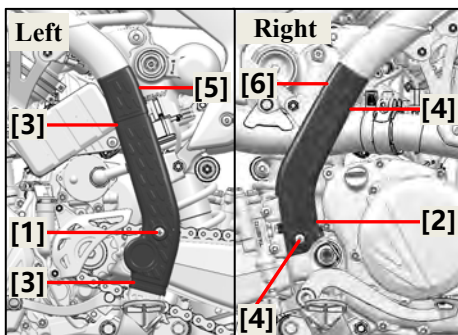
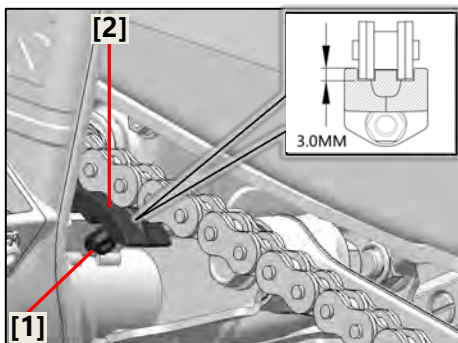
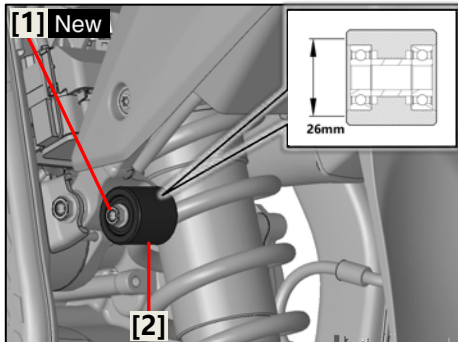

※ **Guide sprocket and guide chain slider**

Disassembly/installation

Disassemble the following parts:

- Screw [1]
- Guide sprocket [2].

Inspection

Check if the sprocket (black) is excessively worn or stuck.

Wear limit not less than:

Diameter: 26 mm

Notes

- Each time you disassemble the guide sprocket bolt, replace it with a new one.
- The installation sequence is reversed from the removal sequence.

Torque :

Guide sprocket and subframe

22 N·m (2.2 kgf·m, 16 lbf·ft)

Chain slider and frame

10 N·m (1.0 kgf·m, 7.0 lbf·ft)

※ **Frame trim (left and right)**

Disassembly/installation

Disassemble the following parts:

- Screw [1][2];
- Cable ties [3], [4];
- Frame trim - left and right [5][6].

The installation sequence is reversed from the removal sequence.

Notes

- If the frame trim is worn or damaged, please replace it promptly.

Torque :

Frame trims (left and right) and frame

5.0 N·m (0.5 kgf·m, 3.7 lbf·ft)

※ **Pedal assembly**

Disassembly/installation

Disassemble the following parts:

- Cotter pin and shim [1];
- Pedal pin [2];
- Left and right pedals [3].

The installation sequence is reversed from the removal sequence.

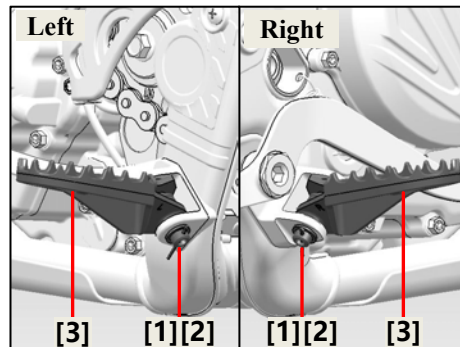

※ **Oil pipe clip**

Disassembly/installation

Disassemble the following parts:

- Bolt [1];
- Front brake hose clamp [2];

The installation sequence is reversed from the removal sequence.

Torque:

Oil pipe clamp and lower connecting plate

10 N·m (1.0 kgf·m, 7.0 lbf·ft)

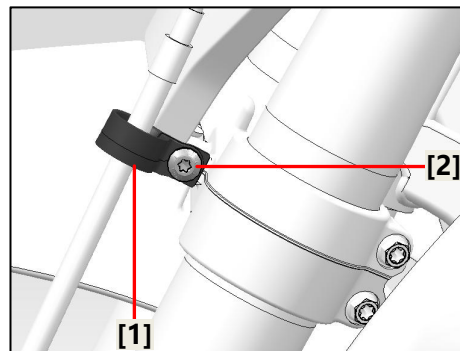

※ **Gear shift assembly**

Disassembly/installation

Disassemble the following parts:

- Bolt [1];
- Gear shift rocker arm assembly [2].

The installation sequence is reversed from the removal sequence.

Torque:

Shift rocker arm and engine

10 N·m (1.0 kgf·m, 7.0 lbf·ft)

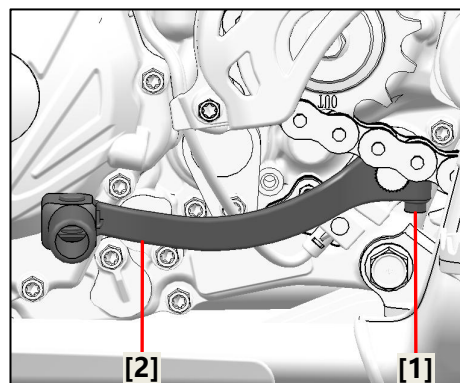

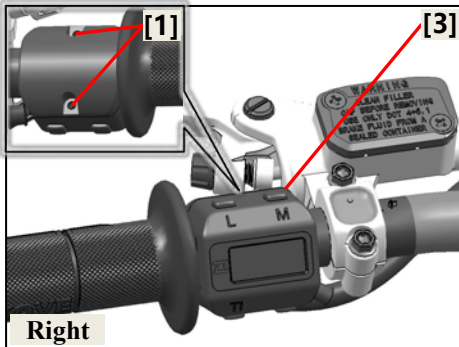

※ **Handlebar switch-left**

Disassembly/installation

Disassemble the following parts:

- Screw [1]
- Cable plug [2];
- Left handlebar switch assembly [3].

The installation sequence is reversed from the removal sequence.

Torque:

Handlebar switch - left mounting screw
3.0 N·m (0.3 kgf·m, 2.2 lbf·ft)

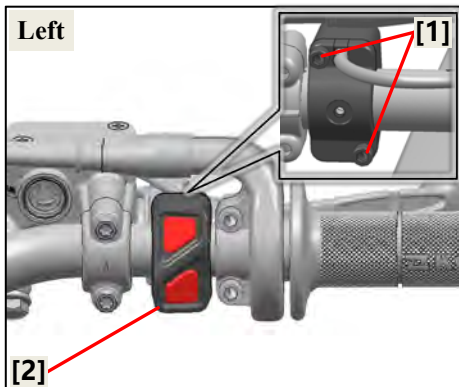
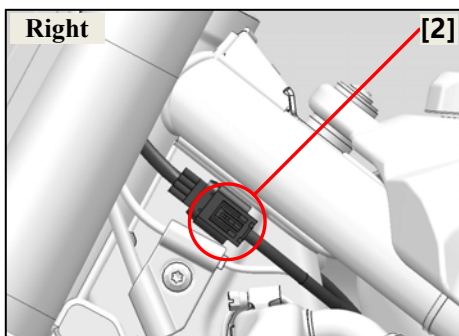

※ **Handle switch-right**

Disassembly/installation

Disassemble the following parts:

- Screw [1]
- Cable plug [2];
- Handlebar switch - right [3].

The installation sequence is reversed from the removal sequence.

Torque:

Handlebar switch - right mounting screw
4.0 N·m (0.4 kgf·m, 3.0 lbf.ft)

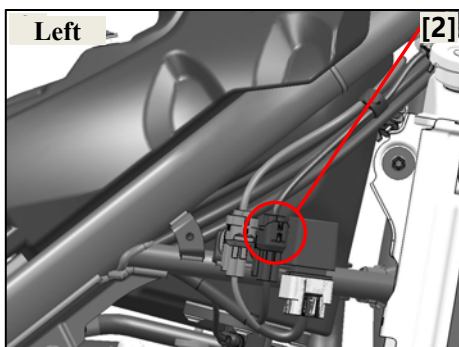

※ **Electronic control unit (ECU)**

Disassembly/installation

Disassemble the following parts:

- Press position [1] while simultaneously turning position [2] clockwise to disconnect ECU from the connection plug [3];
- Remove ECU control unit and rubber grommet from the clip [4].

The installation sequence is reversed from the removal sequence.

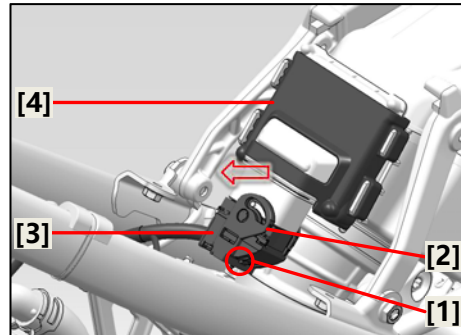

※ **Split-type ignition coil**

Disassembly/installation

Disassemble the following parts:

- Plug [1];
- Clip [2];
- Screw [3];
- High-voltage coil [4];
- Spark plug cap [5].

The installation sequence is reversed from the removal sequence.

Torque:

High-voltage coil mounting bolt

10 N·m (1.0 kgf·m, 7.0 lbf·ft)

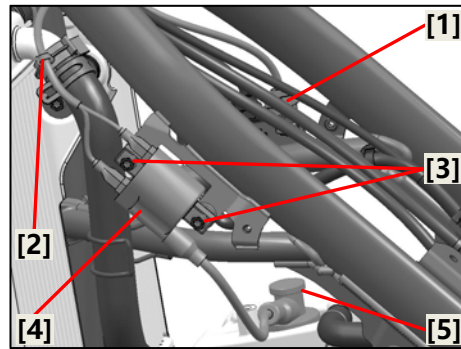

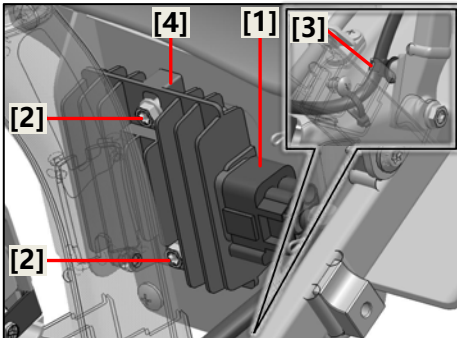

※ **Regulating rectifier**

Disassembly/installation

Disassemble the following parts:

- 6-pin plug [1];
- Screw [2];
- Wire clip [3];
- Regulating rectifier [4].

The installation sequence is reversed from the removal sequence.

Torque:

Regulating rectifier and air filter tank

10 N·m (1.0 kgf·m, 7.0 lbf·ft)

※ **Starting relay**

Disassembly/installation

Disassemble the following parts:

- 4-pin plug [1];
- Bolts [2];
- Starting relay and rubber grommet [3].

The installation sequence is reversed from the removal sequence.

Torque:

Starting relay connecting bolt

5.0 N·m (0.5 kgf·m, 3.7 lbf·ft)

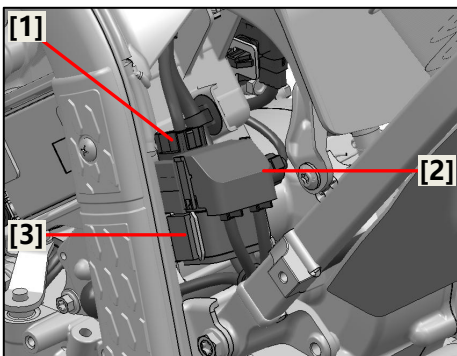

※ **Main relay**

Disassembly/installation

Disassemble the following parts:

- 8-pin plug [1];
- Main relay and rubber grommet [2].

The installation sequence is reversed from the removal sequence.

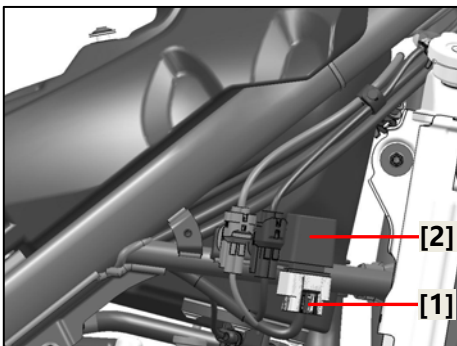

※ **Battery box**



- Disassemble only after disconnecting the negative battery terminal.

1. Disassemble:

- Seat cushion assembly
- Front tank trim (left)

See "Frame, Body Trim, Exhaust System" on page 39 for details.

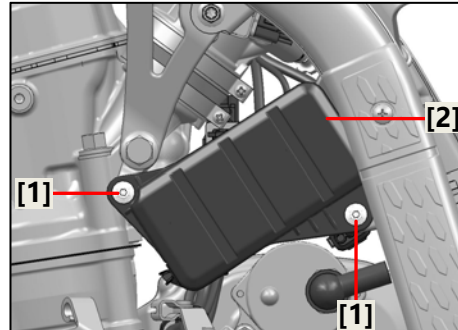

2. Disassemble:

Battery box

- Screw [1]
- Battery box cover [2];
- Negative battery cable [3];
- Positive battery cable [4];
- Battery [5];
- Rubber gasket [6];
- Wire clip [7];
- Connector bracket [8];
- Main cable wire clip [9];
- Bolt [10];
- Battery box [11].

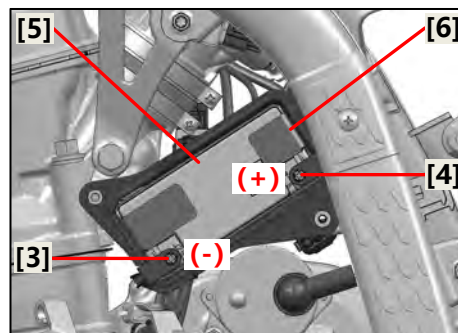

The installation sequence is reversed from the removal sequence.

Notes

- When installing, correctly route the wiring harness and plugs.

Torque:

Battery box cover mounting bolts

5.0 N·m (0.5 kgf·m, 3.7 lbf·ft)

Battery terminal mounting screw

5.0 N·m (0.5 kgf·m, 3.7 lbf·ft)

Battery box and frame

Battery box and engine upper suspension - left

8.0 N·m (0.8 kgf·m, 6.0 lbf.ft)

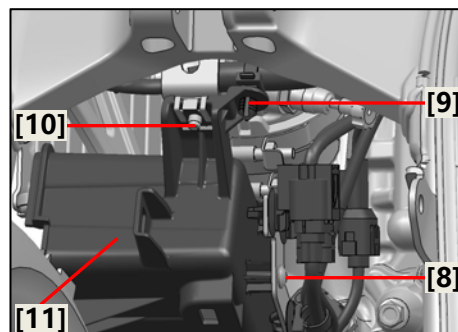

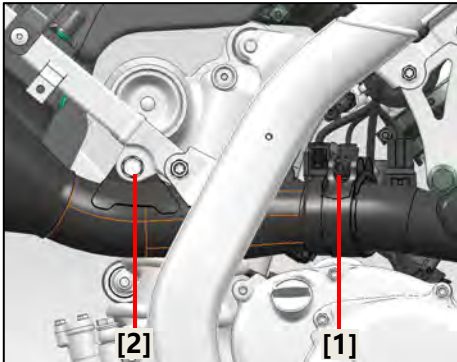

※ **Muffler assembly**



- Wait for the muffler to cool down before disassembly to avoid burns.

1. Disassembly

Muffler rear section

- Pipe clamp locking bolt [1];
- Bolts [2];
- Bracket mounting bolt [3];
- Muffler rear section [4].

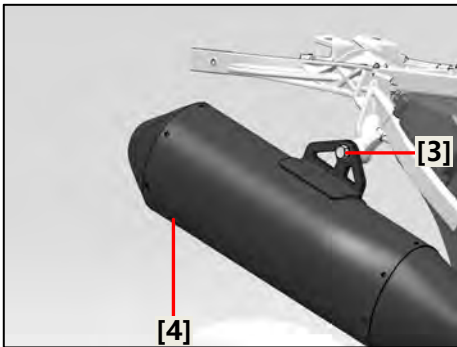

2. Disassembly

Muffler front section

- Nut [5];
- Muffler front section [6].

3. Inspection:

- Muffler gasket
Exhaust leakage → Replace
- Muffler pipe
Crack/damage → Replace.

4. Installation

The installation sequence is reversed from the removal sequence.

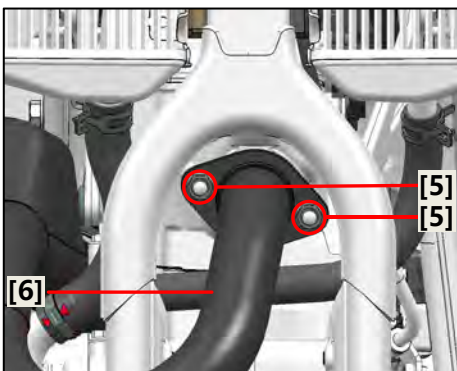

Notes

- If the muffler becomes louder after the vehicle has been used for a period of time, please contact your local dealer promptly for inspection or repair.

Torque:

Muffler front section guard mounting screw

5.0 N·m (0.5 kgf·m, 3.7 lbf·ft)

Muffler front section and engine exhaust port (nut)

16 N·m (1.6 kgf·m, 12 lbf·ft)

Muffler rear section and subframe

Muffler rear section and subframe (rear)

22 N·m (2.2 kgf·m, 16 lbf·ft)

Muffler front and rear section (clamp)

22 N·m (2.2 kgf·m, 16 lbf·ft)

※ **Subframe and air filter assembly**

Disassembly/installation
Disassemble the following parts:

- Clamp [1];
- Exhaust pipe [2];
 - Right bolt [3];
 - Left bolt [4];
 - Subframe and air filter assembly [5];
 - Screw [6];
 - Air filter assembly [7].

The installation sequence is reversed from the removal sequence.

Inspection

As shown in Figures 2 and 3:

- Check if the mounting bolts and clamps of the air filter tank are loose.

Loose → Tighten.

- Replace the air filter element according to the maintenance schedule or whenever

Too dirty or damaged → Replace.

Note

- If you frequently ride in wet or dusty areas, maintain the air filter more frequently.

Torque:

Air filter and subframe mounting bolt

5.0 N·m (0.5 kgf·m, 3.7 lbf·ft)

Connecting bolt between subframe and main frame

34 N·m (3.4 kgf·m, 18 lbf·ft)

※ **Rear fender**

Disassembly/installation
Disassemble the following parts:

- ST4.8x15 self-tapping screws [1]-[5], [6].
- Rear fender [7].

The installation sequence is reversed from the removal sequence.

Torque:

Rear fender and air filter (rear housing)

2.0 N·m (0.2 kgf·m, 1.5 lbf·ft)

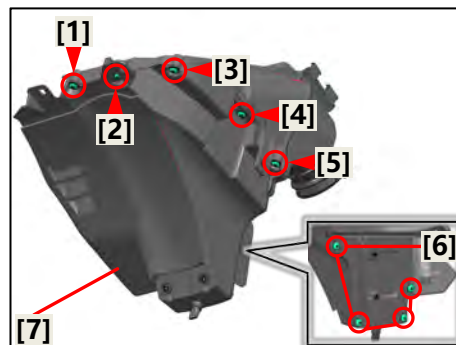
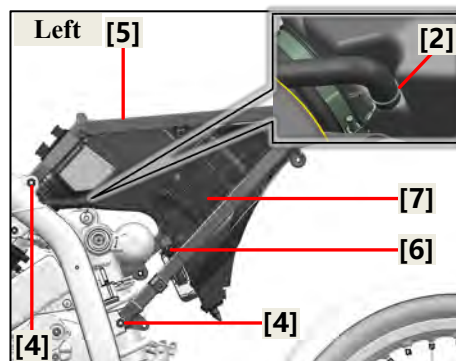
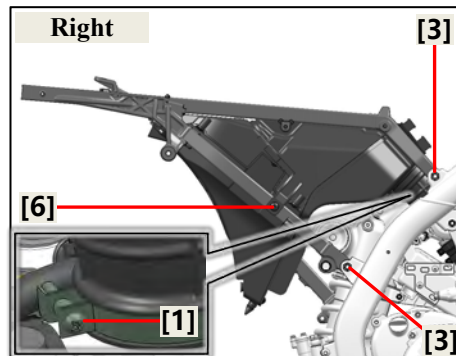

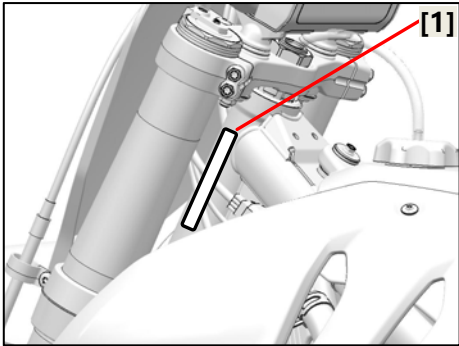

※ **Frame serial number and engine number**

When registering a motorcycle, the frame number and engine number need to be provided. These numbers are unique and used to identify your vehicle. (Tampering without informing is strictly prohibited.) They may also be required when ordering accessories. You can record this number in this manual.

The VIN [1] is printed on the right side of the frame's head tube.

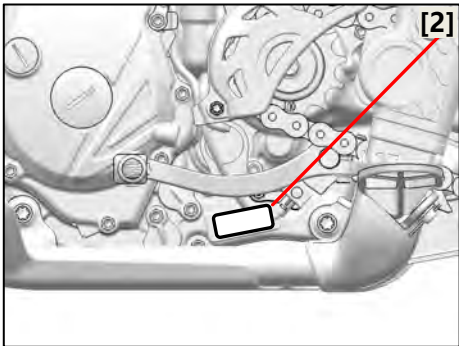

The engine SN [2] is printed on the left-hand crankcase.

Cooling System

Section 1 Maintenance instructions	64
Section 2 Troubleshooting	65
Section 4 Cooling system test	66
Section 5 Coolant replacement/exhausting	67
Section 6 Pressure relief pipe and pressure relief fixing socket	68
Section 7 Radiator inlet and outlet pipes and connecting pipes for left and right radiators	68
Section 8 Radiator, radiator grille	69
Section 9 Engine water pump	70

Maintenance Instructions

Overview:



- Do not remove the radiator cap before the engine and radiator have cooled down, to prevent the coolant from splashing and scalding people.

Note:

Using tap water will cause engine damage.

- Do not disassemble the radiator cap except when adding or draining the coolant.
- It is not necessary to remove the engine from the frame when servicing the cooling system.
- Avoid spilling coolant on painted surfaces.

Cooling system specification

Item		Specification
Coolant capacity	Radiator and engine	1.2 L
Radiator cap relief pressure		1.7bar
Recommended coolant		Ethanol-containing silicate-free coolant
Standard coolant concentration		Mix with distilled water in a 1:1 ratio.

Troubleshooting

Engine temperature too high

- Water temperature sensor failure
- Insufficient coolant
- Radiator outlet
- Radiator passages, hoses, water pipes blocked
- Circulatory system intake
- Water pump failure
- Insufficient coolant

Coolant leakage

- Defects in water pump mechanical mechanism
- O-ring seal ring aged
- Radiator outlet
- Leakage or damage of cylinder head gasket
- Loosen connection of hose or untightened clamp
- Hoses damaged or aged
- Radiator damaged
- Thermostat cover and water pump cover pipe joints loose

Flow Chart of Cooling System

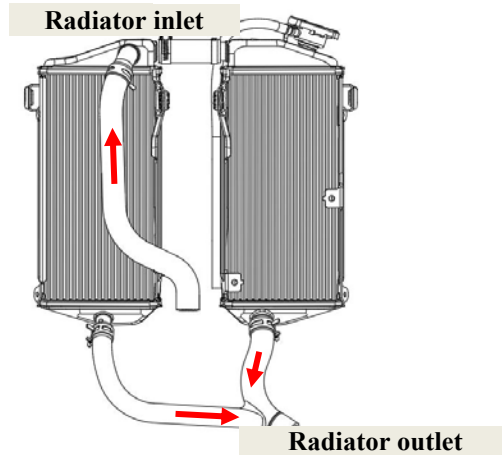

※ Cooling system test

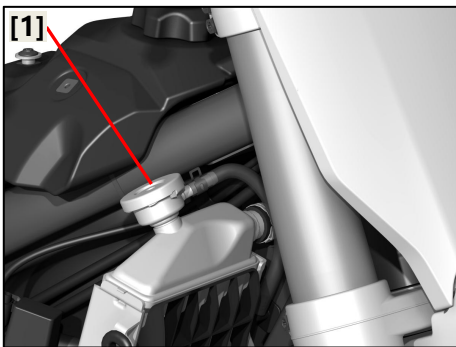

Radiator cap/system pressure detection
- Remove the radiator cap [1].

Install the radiator cap tester [1] and radiator cap tester adapter [2] to the radiator cap [3].

Pressurize the radiator cap with a tester.

If the radiator cap cannot maintain the pressure or the released pressure is too high or too low, replace the radiator cap.

The radiator cap must maintain the specified pressure for at least 6 seconds.

Release the pressure of the radiator cap : 130-170Kpa(Standard value: 1.7bar)

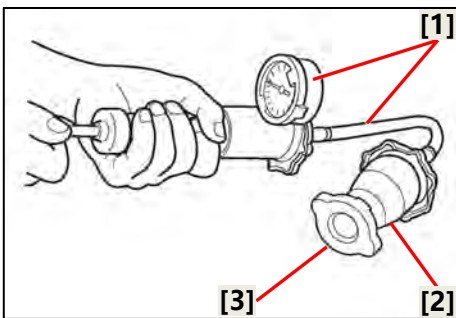

Connect the detector to the radiator.

Use the detector to pressurize the radiator, engine and hose to check their air tightness.

Notes

- This operation shall be conducted when the vehicle is in cold status.
- Excessive pressure will damage cooling system components. Do not exceed 170kPa.
- If the system cannot maintain the specified pressure for at least 6s, repair or replace the component.

※ **Coolant replacement**

1. Stand the vehicle on a flat ground.

Note

- Place the motorcycle on the appropriate bracket.
- Make sure the motorcycle stays upright.



- The pressure of the hot radiator will rise. Therefore do not remove the radiator cap when the engine is hot. Serious injury may occur when hot liquid and vapor are sprayed out. Wait for the engine to cool, then open the radiator cap as follows:

Cover the radiator cap with a thick cloth such as a towel, rotate the cap slowly counterclockwise until it touches the detent, allowing residual pressure to release. Wait for the hissing sound to stop before pressing down on the radiator cap and rotating it counterclockwise to remove it.

2. Disassemble:

- Remove water pump drain bolt [1] and flat gasket [2].
- Remove the radiator cap and drain the coolant.

Torque:

Water pump drain bolt

10 N·m (1.0 kgf·m, 7.0 lbf·ft)

3. Adding:

- Using the water hole, fill the cooling system with the recommended coolant up to the neck [1].

Recommended antifreeze:

Ethanol-containing silicate-free coolant

Radiator (including all lines)

Filling: 1200 mL (milliliters)



- If coolant splashes on your eyes, please rinse your eyes thoroughly with clear water and seek medical advice.

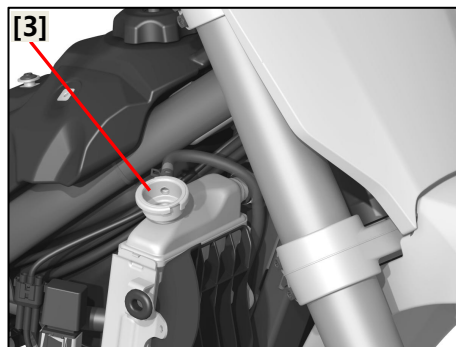
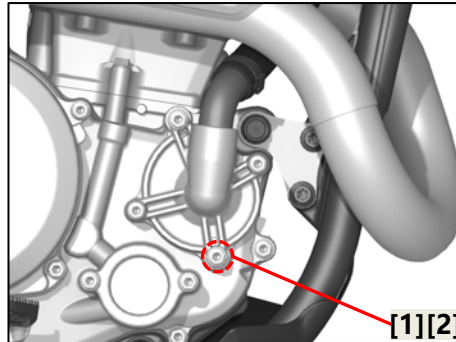

Notes

- If water is used instead of coolant, check and correct the coolant concentration if necessary.
- Use distilled water only. In the absence of distilled water, soft water can be used as an alternative.
- Ensure not to mix different types of coolants.

Air venting inside the radiator

Exhaust air from the radiator system as follows:

1. Shift the engine into neutral, start it, and let it idle for 2-3 minutes.
2. Open and close the throttle 3 or 4 times to remove the air inside completely.
3. Install the radiator cap.
4. Turn off the engine and, if necessary, add coolant to the radiator up to the neck.
5. Check the coolant for leaks.

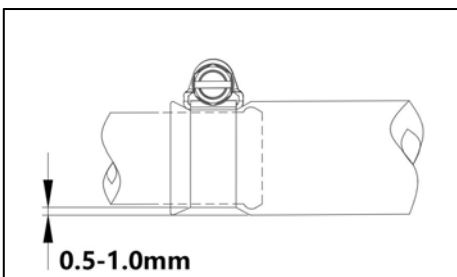
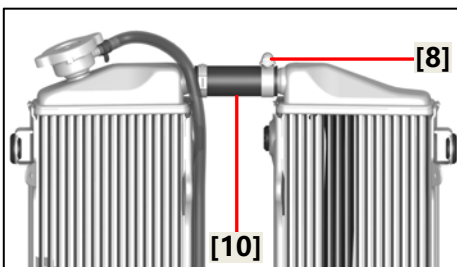
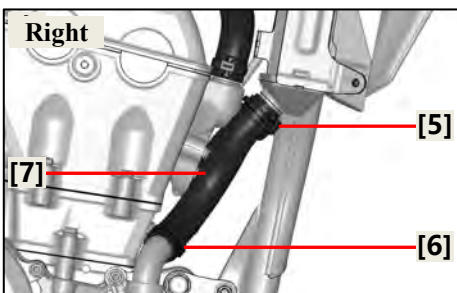
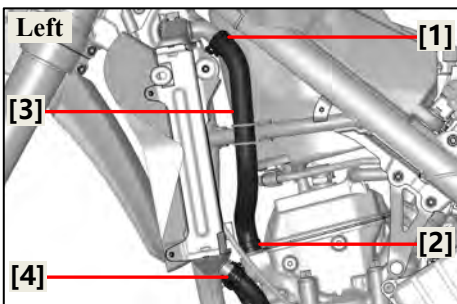
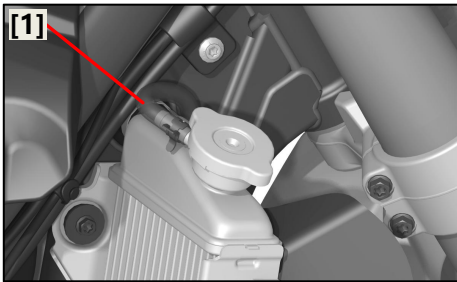

※ **Pressure relief pipe**

Notes

- Try to operate when the engine is in cold status.

Disassembly/installation

Disassemble the following parts:

- Pressure relief pipe fixing socket [1].

※ **Radiator inlet pipe, outlet pipe, and left/right radiator connecting pipes**

Note

- Use special water pipe clamps and similar tools for disassembly and assembly.

1. Disassembly

Radiator inlet pipe

- Inlet pipe spring clamp [1];
- Inlet single-ear clamp [2];
- Radiator inlet pipe [3].

Radiator outlet pipe

- Outlet pipe spring clamp [4], [5];
- Outlet pipe single-ear clamp [6];
- Radiator outlet pipe [7].

Left and right radiator connecting pipes

- Connecting pipe threaded clamp [8];
- Connecting pipe single-ear clamp [9];
- Left/right radiator connecting pipes [10].

2. Inspection

- Radiator hose

Crack/damage → Replace.

- Radiator hose connection

Coolant leakage → repair or replace.

3. Installation

The installation sequence is reversed from the removal sequence.

Notes

- Try to operate when the engine is in cold status, while drain the radiator and antifreeze in the water channel in advance.

As shown in the left figure: It is a diagram of the connecting pipe clamps of the left and right radiators.

※ **Radiator, Radiator Grille**

1. Disassembly

Right radiator and grille

- Screw [1]
- Radiator grille [2];
- Radiator mounting bolts [3], [4];
- Radiator [5]

Left radiator and grille

- Screw [1]
- Radiator grille [2];
- Radiator mounting bolts [3], [4];
- Radiator [5]

2. Inspection

- Heat sink

Blocked → Stuck.

Purged the rear of the radiator with compressed air.

Damage → Repair or replace.

Note

- Use a fine flat-head screwdriver to straighten the flattened radiator pieces.

3. Installation

The installation sequence is reversed from the removal sequence.

Radiator and radiator grille

5.0 N·m (0.5 kgf·m, 3.7 lbf·ft)

Connecting bolts between left radiator and frame

10 N·m (1.0 kgf·m, 7.0 lbf·ft)

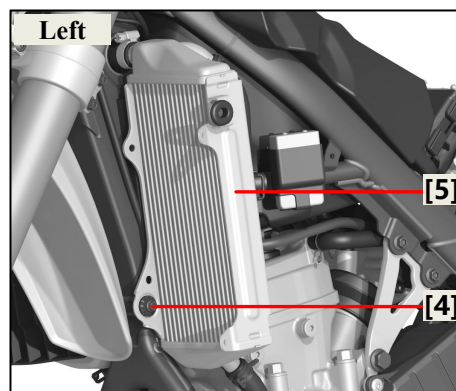
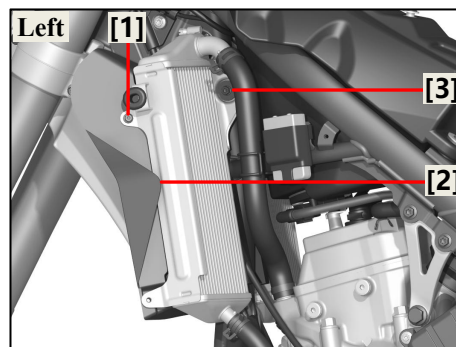
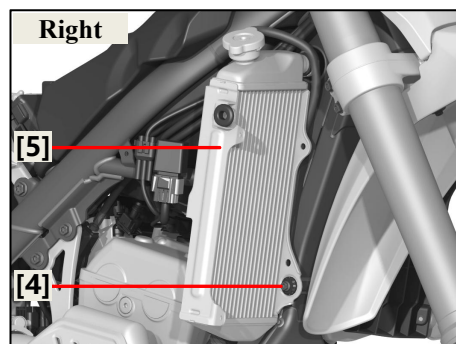
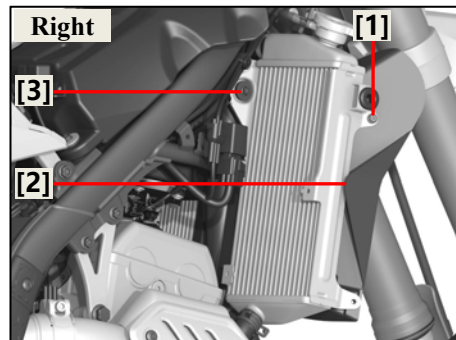

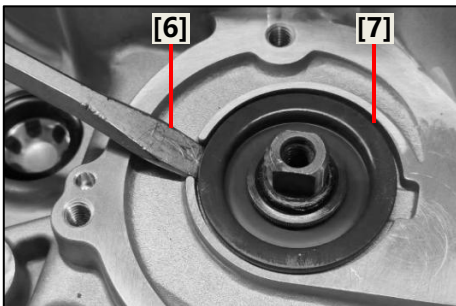
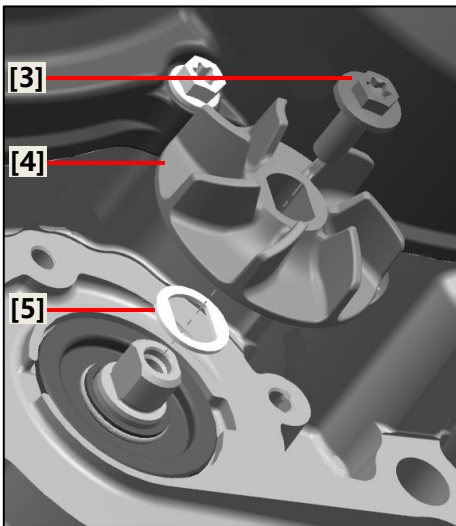
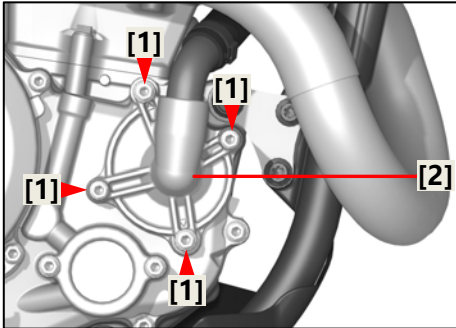

※ Water pump

Disassembly/installation

Disassemble the following parts:

- Drain the coolant.
- 5 water pump cover fastening bolts [1],
- Water pump cover [2] (including the sealing ring);

- Water pump cover [2] (including the sealing ring);
- Water pump impeller [4].
- Flat washer [5].

Notes

- If the clutch assembly has been disassembled when removing the water pump cover impeller fastening bolt, the clutch housing needs to be reinstalled to fix the oil pump drive sprocket. Do not touch the water pump impeller during disassembly to prevent injury.

- Use a slotted screwdriver [6] to remove the oil-water seal through the process disassembly position. Do not damage the sealing surface of the water pump cover on the box body.

- The installation sequence is reversed from the removal sequence.

Torque:

Water pump cover fastening bolt

Water pump impeller fastening bolt

10 N·m (1.0 kgf·m, 7.0 lbf·ft)

Engine

Section 1 Maintenance instructions	72
Section 2 Position of components	73
Section 3 Inspection of engine intake pipe	74
Section 4 Removing and installing of engine	75
Section 5 Engine parameter specifications	78
Section 6 Torque value - engine torque value	81
Section 7 Engine lubrication and sealing position	83
Section 8 Engine idle speed check	85
Section 9 Piston, piston ring, piston pin	85
Section 10 Radiator coolant	92
Section 11 Cooling System	93
Section 12 Drive sprocket	93
Section 13 Clutch	94

Maintenance Instructions

1. Please use the parts, lubricating oils or other auxiliary materials produced by or approved and recommended by Xinchiyue Power Equipment Co., Ltd. If the materials used fail to meet the specifications or requirements, the motorcycle may be damaged.
2. Do not use the non-metric tools at the time of maintenance. Metric bolts, nuts and screws cannot be interchanged with inch fasteners.
3. When reassembling, replace the washer, O-ring, cotter pin and lock plate with new ones.
4. When tightening bolts or nuts, first tighten the larger diameter bolts or the inner bolts. Then gradually tighten each bolt to its specified torque value in a diagonal sequence, unless a special order is specified.
5. Use detergent to clean the removed components. Before assembly, apply lubricating oil to the sliding surfaces of the parts.
6. After reassembly, check the parts in each part for correct installation, proper operation, rotation and movement.
7. During maintenance, it is necessary to conduct coolant, engine oil, discarded components, and other pollutants in accordance with national environmental protection requirements.

Position of Components

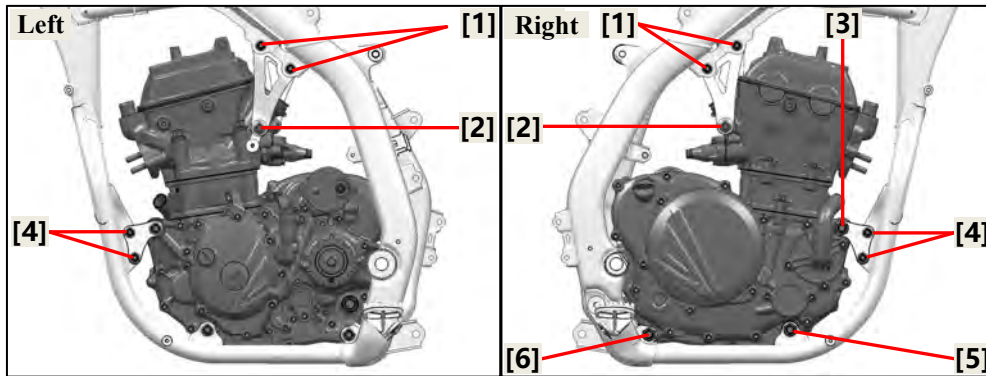

Tightening torque by position and name:

S/N	Installment position	Quantity	Specification status	Torque force value N·m
1	Engine upper suspension and frame	4		36
2	Engine upper suspension and engine	2		54
3	Engine front suspension and engine	1		54
4	Engine front suspension and frame	4		26
5	Engine lower-front suspension and frame	1		54
6	Engine lower-rear suspension and frame	1		54

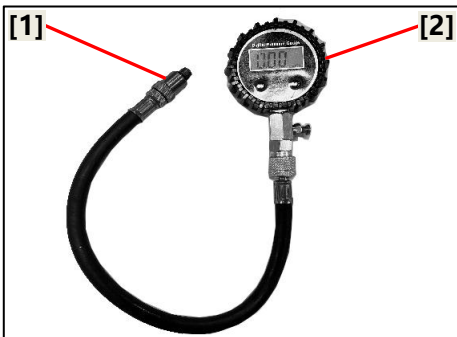
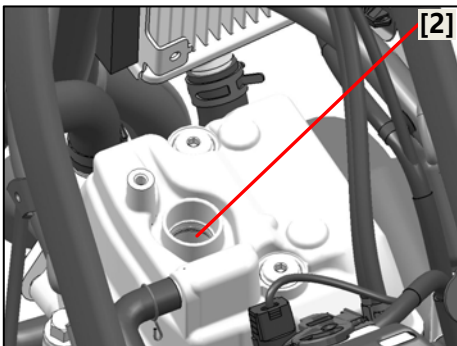
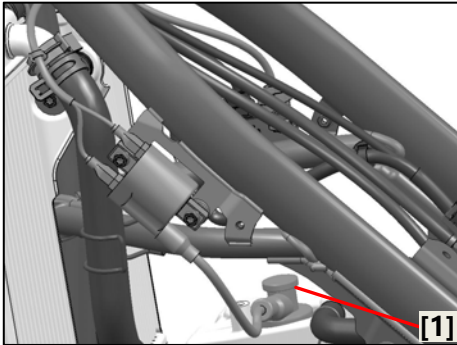

Cylinder pressure (after pouring oil into the cylinder)	
Reading	Diagnosis
Higher than when no oil is poured	The piston ring is worn or damaged → Repair.
The same as when no oil is poured	The piston, valve, cylinder head gasket or piston ring may be damaged → Repair

※ **Inspection of engine intake pipe**

Measurement of cylinder pressure
The following steps apply to all cylinders.

Note

- Insufficient cylinder pressure will cause the engine performance to decline.

1. Measurement:
– Valve clearance

Off-specification → Adjust.

See "**Valve clearance adjustment**" on page 21 for details.

2. Start the engine, warm the motorcycle for several minutes and then turn off the engine.

3. Disassemble:

- Spark plug cap [1];

4. Disassemble:

- Spark plug [2].

Notes

- Before removing the spark plug, blow off the dust accumulated around the spark plug hole with compressed air to prevent dust from falling into the cylinder.

5. Install:

- Adapter [1]
- Cylinder pressure gauge [2]

6. Measurement:

- Cylinder pressure

Off-specification → See steps (c) and (d) for details.

Compression pressure value:

400–600 kPa/390 rpm

- a. Press the vehicle start button.
- b. Fully open the accelerator and let the starting motor run until the reading on the pressure gauge is stable.

Warning

- To avoid sparks, make sure to disconnect all spark plug connectors before starting the engine.

c. If the cylinder pressure exceeds the specified upper limit, check whether there is carbon deposit on the cylinder head, valve surface and piston top. Carbon deposit → Clean up.

d. If the cylinder pressure is below the specified lower limit, pour a small amount of engine oil into the spark plug hole and then measure it again. Please refer to the table on the left.

7. Install:

- Spark plug
- Spark plug
22 N·m (2.2 kgf·m, 16 lb·ft)

※ **Removing and installing of engine**

1. Stand the vehicle on a flat ground.



- Ensure that the vehicle is securely supported and not at risk of tipping over.

2. Disassembly: as shown in Figure 1

- Seat cushion assembly [1];
- Front fuel tank trim - left and right [2];
- Vehicle body - left and right [3];
- Frame trim - left and right [4];
- Front sprocket cover and chain baffle [5];
- Engine lower protector [6].

See "Frame, body trim, exhaust system" on page 45 for details.

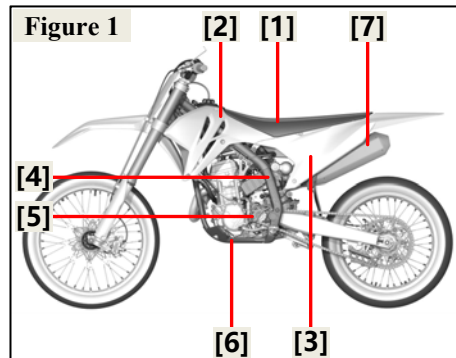

3. Disassembly: as shown in Figure 2

- Battery box cover [1];
- Disconnect the positive and negative terminals of the Battery;
- Battery;
- Shift pedal assembly [2];

See "Frame, body trim, exhaust system" on page 45 for details.

- OBD detection interface [3];
 - Fuel tank assembly [4];
- See "Fuel system" on page 111 for details.

- Radiator assembly - left and right [5];
- Front sprocket (driving sprocket) [6].

See "Drive Sprocket" on page 93 for details.

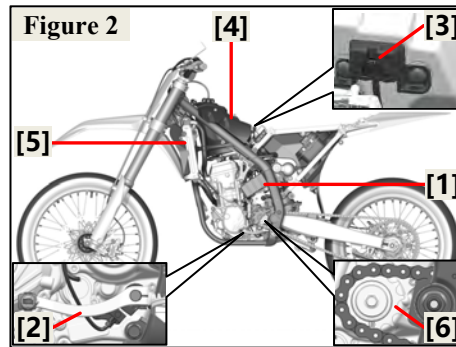

4. Disassembly: as shown in Figure 3

- Clutch cable [1];

See "Regular inspection and adjustment" on page 33 for details.

- Regulating rectifier [2];
- Starting Relay [3];
- ECU control unit [4];

See "Frame, body trim, exhaust system" on page 45 for details.

- Remove the engine harness plug,
- Exhaust pipe, spark plug cap [5];
- Subframe and air filter assembly [6].

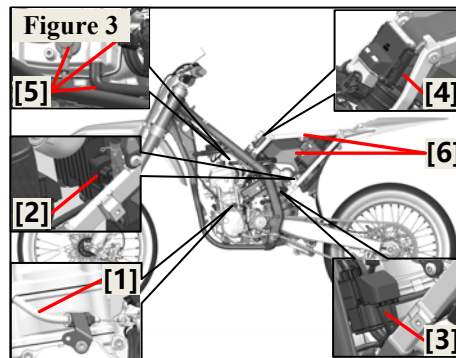

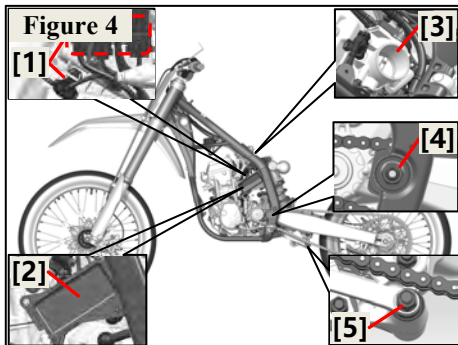

5. Disassembly: as shown in Figure 4

- Plug on the back of the battery box [1];
 - Battery box [2];
- See "Frame, body trim, exhaust system" on page 45 for details.
- Throttle body assembly[3];
- See "Fuel system" on page 111 for details.
- Swingarm axle[4];
 - U swingarm bolt [5].
- See "Rear wheel, suspension" on page 139 for details.

Note

- Place the engine on a jack or other adjustable bracket under the frame;
- The height of the jack must be adjusted continuously to reduce the pressure and facilitate the installation of the bolt;

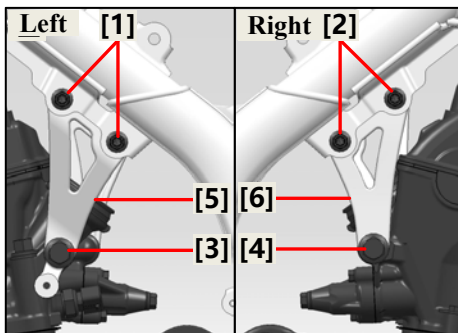

6. Disassembly

- Engine upper suspension bracket/left and right
- Engine upper suspension bracket and frame mounting bolt [1]
 - Engine upper suspension bracket and frame mounting bolt [2]
 - Engine upper suspension bracket and engine mounting bolt [3]
 - Engine upper suspension bracket and engine mounting bolt [4]
 - Engine upper suspension bracket/left and right [5],[6].

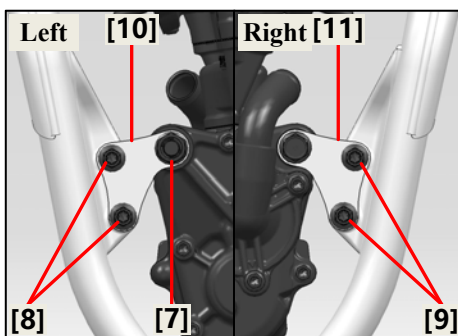

7. Disassembly

- Engine front suspension bracket/left and right
- Engine front suspension bracket and engine mounting nut [7]
 - Engine front suspension bracket and frame mounting bolt [8]
 - Engine front suspension bracket and frame mounting bolt [9]
 - Engine suspension bracket/left and right [10], [11]

8. Disassembly

- Engine lower front and rear mounting brackets (bolts/nuts)
- Engine lower front mounting bracket bolt [12]
 - Engine lower rear mounting bracket bolt [13]
 - Engine lower right mounting bracket bushing [14]
 - Engine assembly [15].

9. Installation

- The installation sequence is reversed from the removal sequence.
 - Torque of engine mounting bolts
- See "Engine disassembly" on page 77 for details

Notes

- The following parts require thread fastening application.
(Huitian 7272)

Engine front suspension - left and right and frame mounting bolts [4]

Engine upper suspension - left and right and frame mounting bolts [5]

Torque:

Connecting bolt between upper engine suspension and frame

36 N·m (3.6 kgf·m, 27 lbf·ft)

Connecting bolt between upper engine suspension and engine

54 N·m (5.4 kgf·m, 40 lbf·ft)

Connecting bolt between front engine suspension and engine

54 N·m (5.4 kgf·m, 40 lbf·ft)

Connecting bolt between front engine suspension and frame

26 N·m (2.6 kgf·m, 19 lbf·ft)

Connecting bolt between lower front engine suspension and frame

54 N·m (5.4 kgf·m, 40 lbf·ft)

Connecting bolt between lower rear engine suspension and frame

54 N·m (5.4 kgf·m, 40 lbf·ft)

Engine installation

Precautions:

- The height of the jack must be adjusted continuously to reduce the pressure and facilitate the installation of the bolt;
- Carefully align the engine mounting points with the frame to prevent damage to the engine and frame;
- First, align the engine lower front and rear suspension mounting points, upper suspension bracket, and front suspension bracket with the frame mounting bores in sequence, then tighten the bolts (nuts).
- Finally, tighten the bolts and nuts to the specified torque.

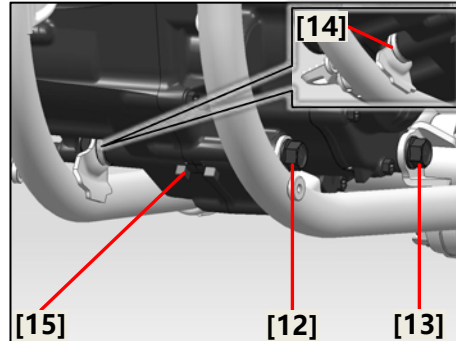

Cylinder head/valve specification Unit: mm

Item		Standard value	Maintenance limit value
Electric starting cylinder pressure		600kPa	—
Valve clearance		Intake valve	0.1±0.03
		Exhaust valve	0.2±0.03
Rocker arm, rockerarm shaft	Rockerarm inner diameter	Intake/exhaust	8.013-8.028
	Rockerarm shaft outer diameter	Intake/exhaust	7.983-7.995
	Clearance between the rocker arm and rockerarm shaft	Intake/exhaust	0.018-0.045
Camshaft	Cam lobe tip height	Intake	33.72-33.79
		Exhaust	32.9-32.935
	Journal-to-bore clearance		0.028-0.069
	Runout		—
Valve, valve conduit	Valve rod diameter	Intake	4.975-4.990
		Exhaust	4.965-4.980
	Inner diameter of valve guide	Intake/exhaust	5.000-5.012
	Clearance between valve rod and valve guide	Intake	0.01-0.037
		Exhaust	0.02-0.047
	Valve seat width	Intake	0.90-1.10
Exhaust		1.0-1.20	
Free length of valve spring		Intake inner spring	34
		Intake outer spring	37.3
		Exhaust outer spring	40.5
Flatness of cylinder head		—	0.10

Specification of Clutch and Shift Mechanism Unit: mm

Item		Standard value	Maintenance limit value
Free stroke of clutch handle		10-20	—
Clutch	Free length of spring	47.5	46.5
	Thickness of driving friction plate	2.9-3.1	2.8
	Flatness of driven friction plate	0.10	-
Clutch bushing	Inner diameter	20.000-20.021	20.031
	Outer diameter	24.962-24.98	24.952
Clutch bushing main shaft outer diameter		19.959-19.980	19.949

Specifications of Magneto and Starting Clutch Unit: mm

Item	Standard value	Maintenance limit value
Outer diameter of overrunning clutch shaft sleeve	25.979-26	25.959
inner diameter of disc gear shaft sleeve	30-30.027	30.047
Outer diameter of disc gear shaft sleeve	39.622-39.635	39.602

Specification of Housing and Transmission Unit: mm

Item		Standard value	Maintenance limit value
Transmission drum, shift fork, shift fork shaft	Outer diameter of main shaft shift fork shaft	10.966-11.984	10.956
	Inner diameter of main shaft shift fork	11.000-11.018	11.028
	Thickness of main shaft shift fork tip	4.93-5	4.9
	Outer diameter of counter shaft shift fork shaft	11.966-11.984	11.956
	Inner diameter of counter shaft shift fork	12.000-12.018	12.028
	Thickness of countershaft shift fork tip	4.93-5	4.9
	Transmission drum shaft diameter (left)	24.959-24.98	24.949
	Transmission drum shaft diameter (right)	24.959-24.98	24.949
Crankshaft	Connecting rod big end side clearance	0.2-0.65	0.8
	Connecting rod big end axial pin clearance	0.006-0.014	0.05
	Runout	0.03	0.08

**Specifications of Crankshaft, Piston, Cylinder Block and
Balance Shaft** Unit: mm

Item		Standard value	Maintenance limit value	
Cylinder	Cylinder diameter	79.000-79.01	79.1	
	Out-of-roundness	—	0.10	
	Taper	—	0.10	
	Flatness	—	0.10	
Piston, piston pin, piston ring	Diameter of piston base circle	78.945-78.955	78.875	
	Pin hole diameter	16.002-16.008	16.02	
	Piston pin diameter	15.994-16.000	15.98	
	Clearance between piston and piston pin	0.002-0.014	0.04	
	Closed clearance of piston ring	First ring	0.18-0.30	0.40
		Oil ring	0.15-0.60	0.80
Clearance between piston ring and ring groove	Clearance between the first ring and the groove	0.030-0.060	0.10	
Cylinder clearance		0.045-0.065	0.10	
Inner diameter of connecting rod small end		16.021-16.032	16.04	
Fit clearance between connecting rod and pin		0.021-0.038	0.05	

Torque value

Standard torque value

Fastener Type	Torque Value N·m	Fastener Type	Torque Value N·m
5mm bolt and nut	5	5mm Screw	4
6mm bolt and nut	10	6mm Screw	9
8mm bolt and nut	22	6mm flange bolt (8mm head, small flange)	10
10mm bolt and nut	34	6mm flange bolt (8mm head, large flange)	10
12mm bolt and nut	54	6mm flange bolt (10mm head) and nuts	10
		8mm Flange Bolt and Nut	27
		10mm flange bolt and nut	39

Engine torque value

Item	Quantity	Thread diameter mm	Torque Value N·m	Notes
Spark plug	1	10	22	
Left trim cover	1	30	15	
Inspection cover	1	14	6	
Engine fuel drain bolt	1	14	23	

Cooling system

Item	Quantity	Thread diameter mm	Torque Value N·m	Notes
Water pump mounting bolt	3	6	10	
Water pump cover bolt (including drain bolt)	1	6	10	

Cylinder head and valve

Item	Quantity	Thread diameter mm	Torque Value N·m	Notes
Cylinder head bolt	4	10	48	Oil on threads and seating surfaces
Camshaft bracket bolt	8	6	13	
Valve rockerarm shaft bolt	3	10	18	
Cylinder head cover bolts	2	6	10	
Cylinder block connecting bolt	2	6	10	

Clutch and shift mechanism

Item	Quantity	Thread diameter mm	Torque Value N·m	Notes
Center bushing locking nut	1	18	120	Threads coated with oil
Primary driving sprocket bolt	1	18	110	Oil on threads and seating surfaces
Stop plate bolt	1	6	12	Apply fastening glue to the threads
Five-star shift plate positioning bolt	1	8	22	Apply fastening glue to the threads
Five-star plate retainer bolt	2	6	10	Apply fastening glue to the threads
Shift arm positioning bolt	1	8	20	
Right crankcase cover bolts	11	6	10	

Magneto and starting clutch

Item	Quantity	Thread diameter mm	Torque Value N·m	Notes
Magneto rotor nut	1	14	110	Oil on threads and seating surfaces
Magneto spindle bolt	3	6	10	Apply fastening glue to the threads
Trigger fixing bolt	2	5	7	Apply fastening glue to the threads
Left crankcase cover bolts	8	6	10	

Case and transmission system

Item	Quantity	Thread diameter mm	Torque Value N·m	Notes
Balance shaft/main shaft/crankshaft/transmission drum bearing pressure plate	8	6	10	Apply fastening glue to the threads
Crankcase 6mm bolt	16	6	10	
Counter shaft driving sprocket	1	8	31	

Balance shaft

Item	Quantity	Thread diameter mm	Torque Value N·m	Notes
Balance shaft nut	1	12	70	Oil on threads and seating surfaces

Lubrication point

Material	Position	Notes
Engine oil	Rockerarm curved surface and rockerarm bore surface Rockerarm shaft surface Camshaft assembly surface and working surface Decompression valve mating surface Cylinder head camshaft assembly surface Valve rod sliding surface and top end Valve adjustment shim Valve spring and valve spring upper/lower seats Entire surface of timing chain Inner surface of cylinder bore Piston outer surface, piston pin hole, and piston ring groove; piston pin outer surface; piston ring entire surface. Crankshaft connecting rod big end Connecting rod small end bores on both sides of the crankshaft crank pin Entire surface of clutch friction plate Clutch rod sliding surface Clutch rod contact surfaces at both ends Entire surfaces of the oil pump shaft and the inner and outer rotors of the oil pump Shift shaft rod part and shift plate Entire surface of dual gear shaft Starting overrunning clutch bearing contact surface and roller disc tooth sliding surface Entire surface of shift fork shaft Gear teeth (primary drive, crankcase, starting reduction) Each bearing Other rotating areas on the surface of each O-ring	
Multipurpose grease	Starter motor seal ring Gear display switch sensor seal ring Engine oil strainer mating end face	
Degreaser	All joint surfaces	

Sealing position

Material	Position	Specification
Sealing washer	Cylinder head rocker arm shaft bolt	M10, 3 pcs
	Cylinder head cam bracket spark plug bore bolt	M6, 1 pc
	Cylinder block and case mating surface bolt	M6, 1 pc
	Right crankcase cover chain cavity bolt	M6, 2 pcs
	Cooling pump cover drain bore bolt	M6, 2 pcs
	Cylinder head and cylinder block mating surface	/
	Clutch cover and right crankcase cover mating surface	/
	Right crankcase cover and right crankcase case mating surface	/
	Left front cover and left crankcase mating surface	/
Seal ring	Cylinder head cover bolt shoulder	D20, d11, thickness 3.9 mm
	Cylinder head cover	Alien
	Camshaft bracket spark plug bore	Alien
	Oil passage pipe (both ends)	D=9.8, d=1.9
	Oil passage from oil pump to right crankcase cover	D=9.8, d=1.9
	Engine oil dipstick/oil filler plug	D=18, d=3-3.5
	Cooling pump cover	Alien
	Fine filter cover	D=39.7, d=2.5
	Left trim cover	D=27.4, d=2.4
	Ispection cover	D=13.8, d=2.5
	Output shaft bushing	Widened type, d=23.75
Oil seal	Right crankcase cover: crankshaft oil passage seal	d=14, D=22, b=5
	Left crankcase: crankshaft bushing oil seal	d=31, D=45, b=7
	Right crankcase: driving balance gear oil seal	d=39, D=56, b=7.5
	Balance shaft: driven balance gear oil seal	d=24, D=36, b=7
	Cooling pump: oil seal for cooling pump shaft	d=12, D=22, b=5
	Shift shaft oil seal	d=14, D=22, b=5
	Clutch lever oil seal	d=12, D=18, b=5
Sealant 1596	Crankcase joint surface, cylinder head camshaft bore with two semi-circular openings, magneto outlet port on left front cover	

※ **Engine idle speed check**

▲ Note:

- The engine must be preheated to conduct an accurate Idle speed check.
- When checking the engine idle, if the throttle valve body has an choke knob, please push it in completely.
- Use a tachometer to measure, preferably with a smaller scale, to accurately indicate the speed.

Shift the engine to neutral and securely support the motorcycle.

Start the engine and warm it up.

Stop the engine, install the tachometer, and operate it according to the manufacturer's instructions.

Start the engine and let it idle.

Check the engine idle speed and adjust the idle bolt on the throttle valve body if necessary.

Idle speed: 2000 ± 100 rpm

The more the idle bolt extends, the higher the idle speed, and vice versa.

If the engine idle speed cannot be adjusted, please refer to this manual and conduct maintenance at our authorized dealer.

※ **Piston, piston ring, piston pin**

Before inspecting the piston, it is necessary to drain the coolant and disassemble some of the motorcycle components.

- Disassemble the engine cover.
- Support the motorcycle upright on a flat surface.
- Remove the drain bolt [1] and gasket [2].
- Slowly disassemble the bolts and radiator cap from the radiator cover.

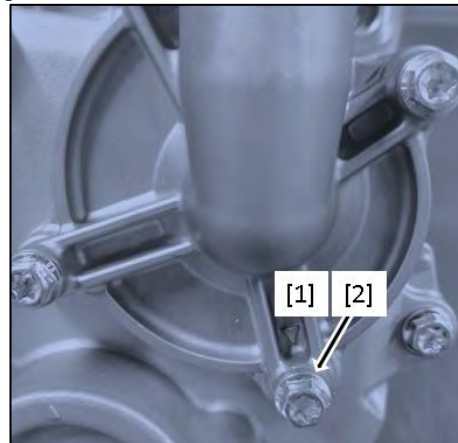

▲ Warning: Always ensure the engine and radiator to cool before opening the radiator cap.

Tilt the engine left and right several times to drain the coolant from the engine.

Disassemble the following parts:

- Exhaust pipe
- Rear suspension
- Air filter
- Body panels
- Fuel tank

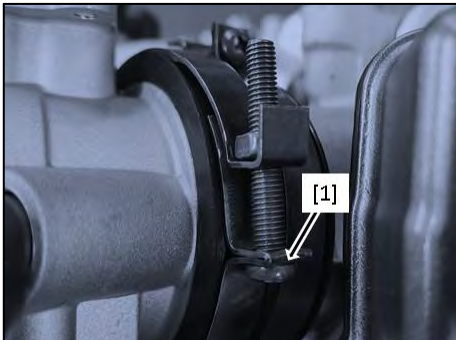

According to P21: **Valve clearance inspection** Disassemble the cylinder head cover, camshaft, and timing chain, etc. Disconnect the water temperature sensor. Loosen the pipe clamp with pliers and disconnect the radiator hose from the cylinder head. Loosen the intake pipe fastening screw [1]. Remove the throttle valve body.

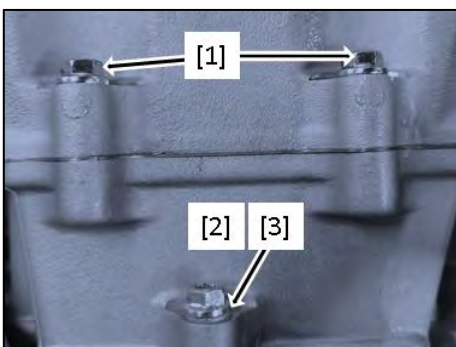

▲ Note:
 • Do not suspend the throttle valve body on the cable to avoid gasoline leakage.
 Remove the left cylinder head mounting plate and bolt.
 Remove the right cylinder head mounting plate and bolt.
 Remove the two M6 bolts [1] connecting the cylinder head and cylinder block.
 Remove the connecting bolt [2] and sealing gasket [3] between the cylinder block and the crankcase.

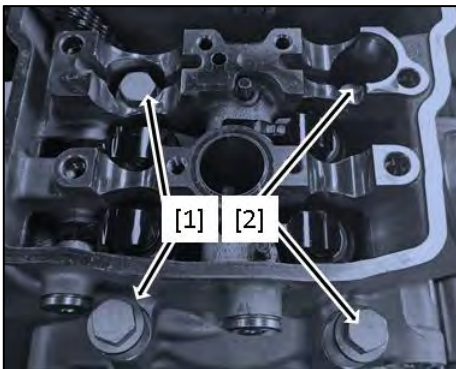

Loosen the M10 bolt for fastening the cylinder head in a crisscross pattern, in two to three steps.
 Remove the cylinder head fastening bolt [1] and shim [2].

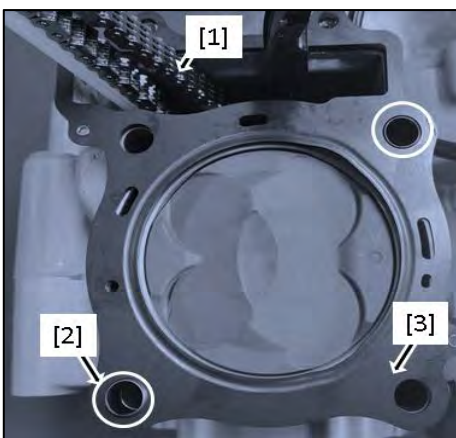

▲ Note:
 • Please do not drop the shim into the crankcase.
 Remove the cylinder head.
 ▲ Note:
 • Please do not drop the timing chain [1] into the crankcase.
 Remove the cylinder head $\phi 12$ dowel pin [2] and cylinder head gasket [3].
 ▲ Note:
 • Please do not drop the dowel pin into the crankcase.

Remove the cylinder block [1] while holding the piston [2].

▲ Note:

- Please do not drop the timing chain [3] into the crankcase.

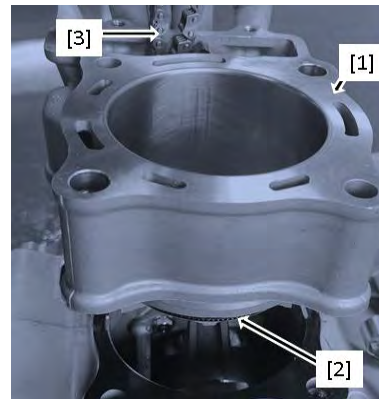

Remove the cylinder block $\phi 12$ dowel pin [1] and cylinder block gasket [2].

▲ Note:

- Please do not drop the dowel pin into the crankcase.

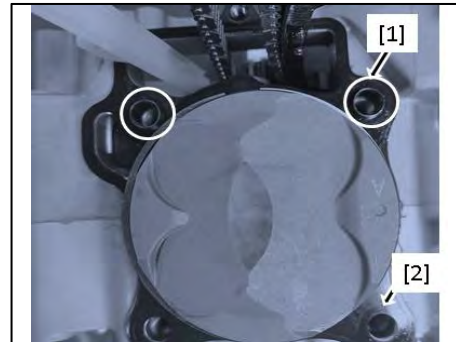

Place a clean, lint-free cloth over the piston bore in the crankcase.

▲ Note:

- Prevent the piston pin retainer from falling into the crankcase.

Use pliers to remove the piston pin retainer [1].

Press the piston pin [2] out of the piston and remove the piston [3].

▲ Note:

- Do not damage the piston pin.

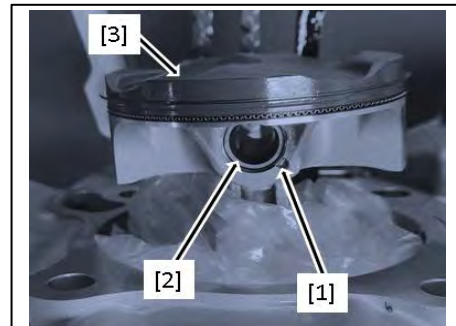

Expand the piston ring and lift it from the side opposite the ring gap.

▲ Note:

- Do not expand the ends of the piston ring too much to avoid damage to the piston ring gap.

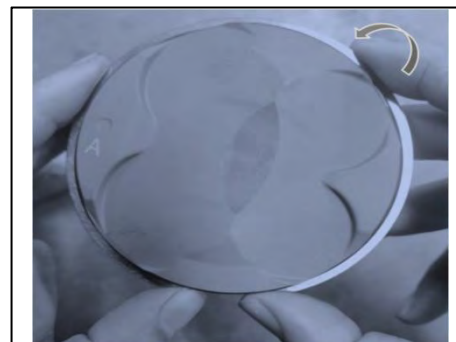

Piston/piston ring/piston pin/connecting rod small end inspection

Check the following components for abrasions, damage, abnormal wear, and deformation.

- Cylinder block
- Piston
- Piston ring
- Piston pin
- Connecting rod small end

Measure each part and calculate the clearance according to the cylinder block/piston specifications.

If the usage limit is exceeded, replace the component.

▲ Note:

- Properly place the piston pin, as wear may cause engine damage.

Cylinder block/piston standards:

- Cylinder block Bore diameter
Standard: 79.000-79.010 mm
Usage limit: 79.100 mm
- Perpendicularity
Usage limit: $\phi 0.05$ mm

Piston/piston pin/piston ring

- Piston outer diameter: 8 mm up from the bottom of the skirt.

Standard: 78.945-78.955 mm

Usage limit: 78.845 mm

- Piston pin bore diameter:

Standard: 16.002-16.008 mm

Usage limit: 16.020 mm

- Outer diameter of piston pin:

Standard: 15.994-16.000 mm

Usage limit: 15.980 mm

- First ring opening gap:

Standard: 0.18-0.30 mm

Usage limit: 0.40 mm

- Oil ring wiper ring opening clearance:

Standard: 0.15-0.60 mm

Usage limit: 0.8 mm

- Clearance between the first ring and the groove:

Standard: 0.030-0.060 mm

- Inner diameter of the connecting rod small end:

Standard: 16.021-16.032 mm

Usage limit: 16.04 mm

Install piston, piston pin, and piston ring

Thoroughly clean the piston's groove.

▲ Note:

- When cleaning the piston ring groove, do not damage the piston.

Apply engine oil to the entire surface of each piston ring.

First, install the oil ring lining ring [1] onto the piston [3], then install the oil ring wiper ring [2] onto the piston.

Install the first ring [4] on the piston with the "DY" mark [5] facing upward.

▲ Note:

- Do not expand the ends of the first ring too much to avoid damaging the piston ring.
- When installing the piston ring, be careful not to damage it.
- The wiper ring gap is 180° apart, with the lowest wiper ring located on the exhaust side.
- The oil ring is positioned on the left/right sides, with the wiper ring gap at a 90° angle.
- The first ring gap is at a 90° angle to the wiper ring gap.
- After installation, check if the oil ring rotates smoothly without any sticking.

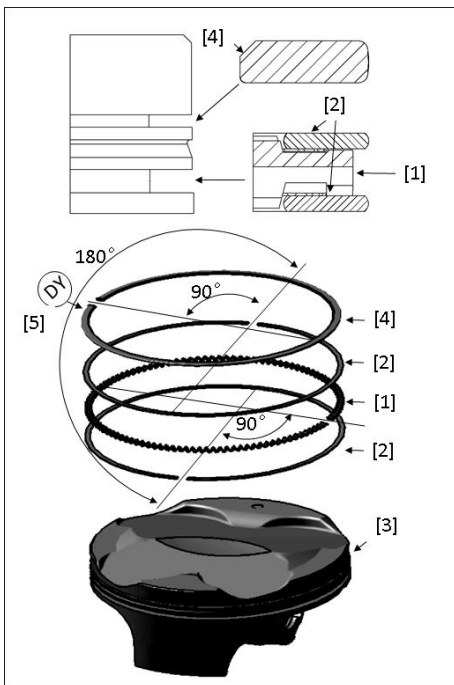

Cover the piston bore of the crankcase with a clean, lint-free cloth to prevent the piston pin retainer from falling into the crankcase. Apply engine oil to the inner surface of the connecting rod small end [1].

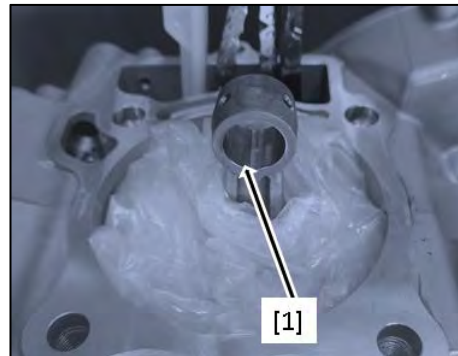

Apply engine oil to the outer surface of the piston [1] and the piston pin bore. Apply engine oil to the surface of the piston pin [2]. The piston top with the "O" marking [3] faces the intake direction [4].

▲ Note:

- Do not damage the piston pin.
- Be careful not to drop the piston pin retainer [5] into the crankcase.
- Do not align the piston pin retainer opening with the piston bore.
- Ensure the piston pin retainer is securely seated in the groove [6].

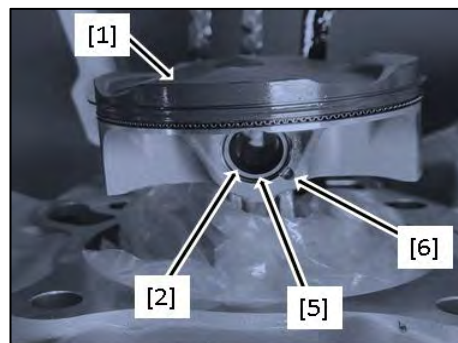

Clean the mating surface of the crankcase cylinder block [1], including the cylinder block gasket sealing material. Apply 1596 sealant to the three-surface intersection [2] where the crankcase and cylinder block meet.

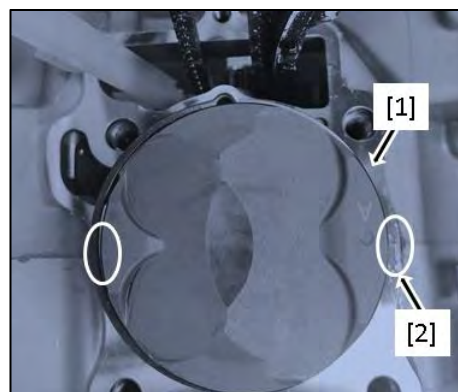

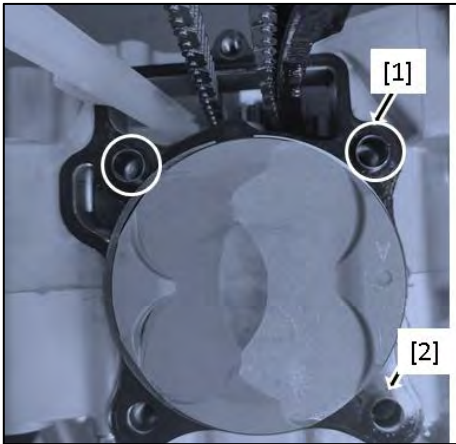

Install the cylinder block $\phi 12$ dowel pin [1] and the new cylinder block gasket [2].

▲ Note:

- Do not drop the dowel pin into the crankcase.

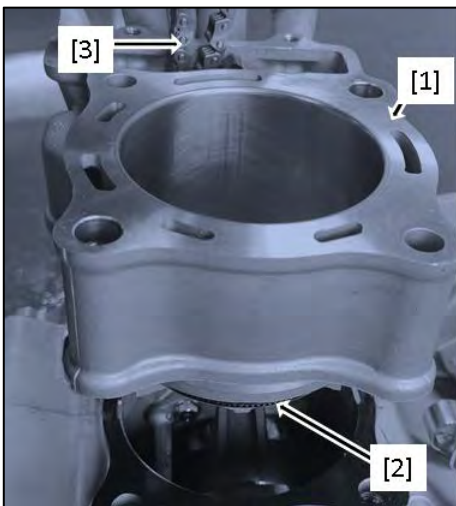

Apply engine oil to the inner surface of the cylinder block wall, the outer surface of the piston, and the entire surface of the piston ring. Assemble the timing chain [3], tensioning panel, and guide panel through the cylinder block chain cavity while compressing the piston ring [2] and assembling the cylinder block [1].

▲ Note:

- Do not damage the piston ring and cylinder wall.

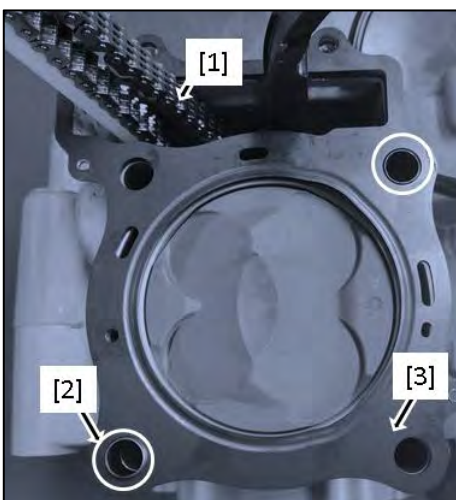

Install the cylinder head $\phi 12$ dowel pin [2] and the new cylinder head gasket [3].

▲ Note:

- Do not drop the timing chain and dowel pin into the crankcase.

Install the cylinder head onto the cylinder block.

▲ Note:

Do not drop the timing chain into the crankcase.

Apply engine oil to the thread and mating surface of the M10 bolt on the cylinder head. Install the cylinder head bolt [1] and shim [2].

Tighten the M10 bolt in a crisscross pattern in two to three steps to the specified torque.

Torque value: 48 N·m

▲ Note:

- Do not drop the washer into the crankcase.

Install the connecting bolts [1] between the cylinder head and cylinder block, and tighten them in two to three steps.

Install the cylinder block bolt [2] and gasket [3].

Tighten the cylinder block bolt.

According to P22: Align the timing position and assemble the camshaft.

According to P23: After checking the valve clearance, reassemble and reinstall the valve back into the engine.

Install the suspension plates and bolts on the left and right sides of the cylinder head.

Install the throttle valve body.

▲ Note:

- Align the throttle valve body lug with the intake pipe groove [1].

Align the intake pipe clamp bore with the positioning bulge [2] on the intake pipe.

Tighten the intake pipe clamp screw until the clamp is fastened.

Install the radiator hose to the cylinder head outlet and adjust the pipe clamp with pliers to secure it in place.

Connect the water temperature sensor.

Support the motorcycle upright on a flat surface.

Install the drain bolt [2] with a new gasket [1] and tighten it.

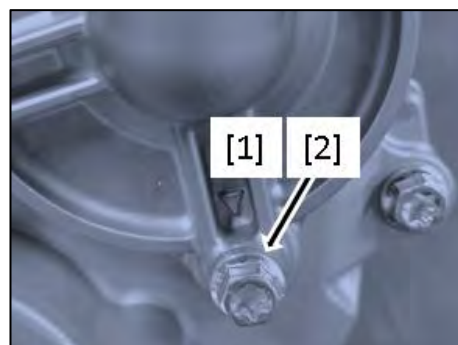
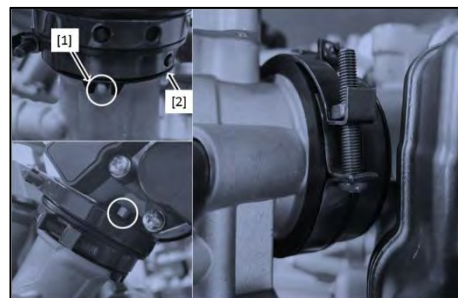
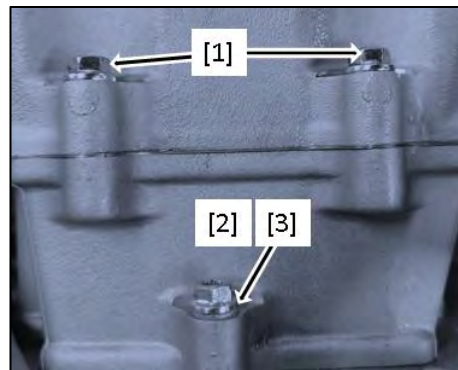
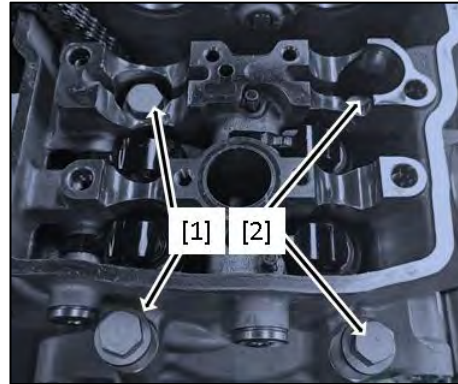

Fill the radiator with the recommended coolant.

Recommended coolant: Ethanol-containing, silicate-free coolant.

Standard coolant concentration: Mix with distilled water in a 1:1 ratio.

Capacity: Please add according to the recommended capacity in the motorcycle instruction manual, generally less than 1.2L.

Tilt the motorcycle left and right by approximately 20° several times to remove air from the cooling system.

If the coolant level drops, continue to add coolant and repeat the exhaust process.

Install the radiator cap according to the motorcycle maintenance manual.

▲ Note:

- If the radiator cap is not installed properly, it can cause abnormal coolant loss, which may lead to overheating or engine damage.
- Install the radiator cap.

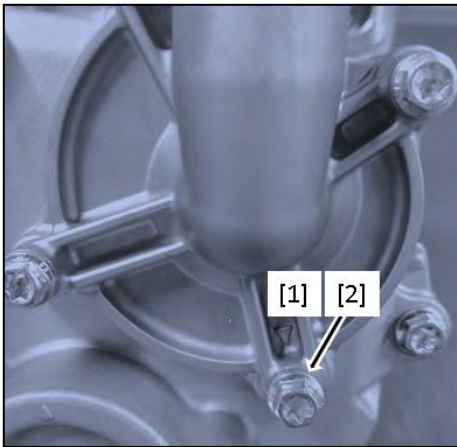

※ Radiator coolant

▲ Note:

- A loss of 20-60 ml of coolant through the radiator overflow pipe is normal. If coolant loss exceeds this value, please check the cooling system.
- Follow the precautions on the radiator.
- When replenishing coolant at the competition site, if coolant is unavailable, high-quality soft water such as drinking water may be used as a temporary substitute. In this case, please replace the water with coolant as soon as possible.
- When the motorcycle is not used for a long time in winter or cold areas, remove the drain bolt [1] and gasket [2] on the water pump cover to drain the coolant.

Remove the bolt and radiator cap from the radiator cover.

▲ Warning:

- Before removing the radiator cap, always allow the engine and radiator to cool.

Check if the coolant is filled up to the radiator neck.

If the coolant level is too low, fill it with the recommended coolant to the neck as needed.

Recommended coolant:

Recommended coolant: Ethanol-containing, silicate-free coolant.

Standard coolant concentration: Mix with distilled water in a 1:1 ratio.

Securely install the radiator cap.

Install the radiator cap.

※ **Cooling System**

Before the match and practice, please check the following:

Coolant leakage.

- When the water pipe is damaged or deteriorated, if the clamp is loose, please replace the clamp.

- Radiator installation status.

Check the water pump bore for any signs of leakage.

When operating the engine, ensure there is no continuous coolant leakage.

▲ Note:

- A small amount of coolant draining from the drain bore is normal.

If the drain bore shows a linear oil or water leak, please visit an authorized dealer to conduct maintenance and adjustment.

Inspect the radiator inlet and outlet pipes, as well as the overflow pipe, for cracks or deterioration, and conduct maintenance or replace according to the motorcycle's user manual.



Drive sprocket

Disassemble the drive sprocket fastening bolt [1], the left rear engine cover [2], and the support plate [3].

Check the gear teeth of the driving sprocket [4] for any wear or damage, and replace if necessary.

Check drive sprocket and bolts

If the sprocket has looseness, tighten it to the specified torque value.

Torque value: 31 N·m.

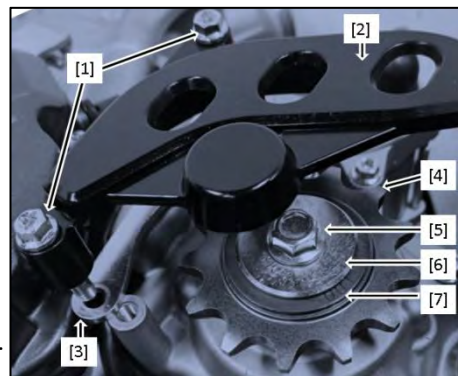

Replace drive sprocket

Disassemble the fastening bolt [4], step shim [5], and disc shim [6].

▲ Note:

- The "OUT SIDE" marking on the disc shim faces outward.

Never use a new drive chain on a wear sprocket. Both the sprocket and chain must be in good condition; otherwise, the newly replaced chain will wear out more quickly.

Install the engine left rear cover [2], support plate [3], and fastening bolt [1].

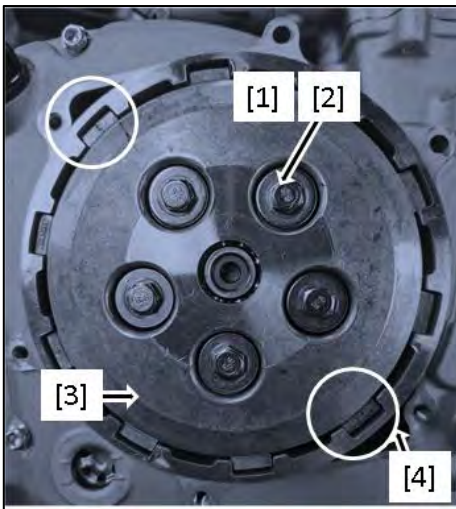
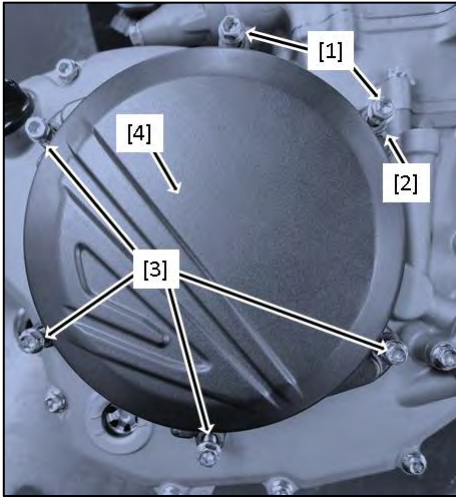

※ **Clutch**

□ **Clutch free play inspection**

Inspect the clutch cable for twists or damage, and lubricate it if necessary.

Measure the free play of the clutch lever at the end of the lever.

Free play: 10-20mm

If the free play is not within the specified range, refer to "Regular inspection and adjustment" on page 33 to conduct the adjustment.

Replace clutch friction plate

Follow the "Oil replacement" procedure to drain the engine oil.

Loosen the following clutch cover bolts:

- 2 M6×45 bolts [1], 1 bolt with gasket at chain cavity position [2].
- 4 M6×20 bolts [3].

Remove the clutch cover bolts, gasket, and clutch cover [4].

▲ **Note:**

- Install 2 M6×45 bolts at the chain cavity position and its attachments.

Loosen the 5 clutch bolt shim assemblies/clutch springs of the pressure plate in a cross pattern, completing the process in two to three steps.

Remove the following components:

- Clutch bolt shim assembly [1].
- Clutch spring [2].
- Clutch pressure plate [3].

▲ **Note:**

- Adjust the clutch friction plate to the position shown in Figure 4, then disassemble the clutch bolt and shim assembly.

Remove the clutch rod [1] and the tappet rod [2].

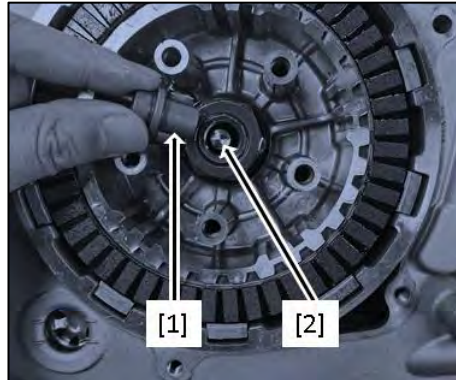

Remove the following components:

- 7 clutch driving friction plates (wide)[1]
- 7 clutch driven friction plates [2]
- 1 clutch driving friction plate (narrow) [3]
- Disc shim[4]
- Flat washer [5]

Inspect the following components for any scratches, damage, abnormal wear, and deformation.

- Clutch spring
- Clutch pressure plate
- Push rod
- Tappet rod
- Clutch driving friction plate and driven friction plate
- Disc spring
- Flat washer

Measure each component according to the clutch specified standard.

Replace component out of usage limits.

▲ Note:

- Clutch springs should be replaced as a set, not individually.
- The clutch driving friction plate and driven friction plate should be replaced as a set, not individually.

Clutch specified standard:

- Clutch driving friction plate thickness
Standard: 2.9–3.1 mm
Usage limit: 2.8 mm
- Clutch driven friction plate flatness
Standard: 0.10 mm
- Clutch spring free length
Standard: 47.5 mm
Usage limit: 46.5 mm

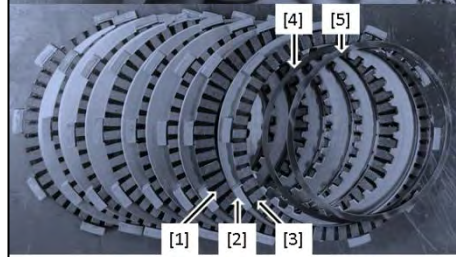

Install flat washers and disc springs.

▲ Note:

- The disc shim is installed with the bowl side facing outward.

Apply engine oil to the clutch's driving friction plate.

Install the driving friction plate (narrow). Starting from the driven friction plate, alternately install the driving friction plate (wide) and the driven friction plate.

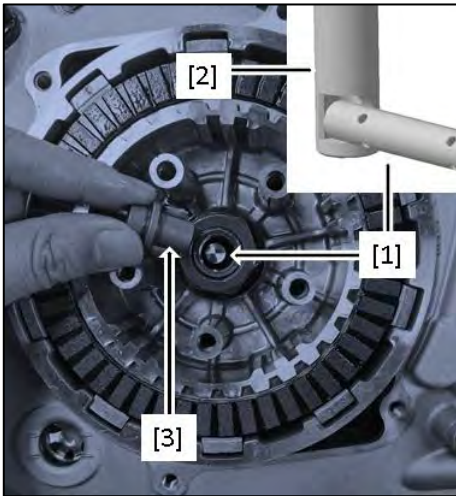

Insert the clutch tappet rod [1] into the main shaft.

▲ Note:

- Rotate the clutch control arm to ensure the tappet rod is properly engaged with the control arm [2] on the left crankcase.

Install the clutch push rod [3].

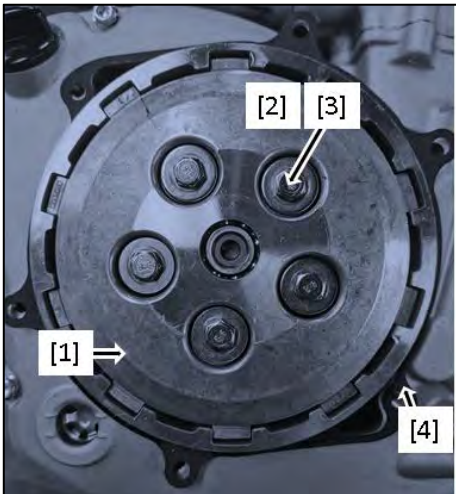

Install the clutch pressure plate [1].

Install the clutch spring [2] and clutch bolt shim [3] assembly.

Tighten the clutch bolt and shim assembly to the specified torque in two to three alternating steps.

Torque value: 10 N·m

Confirm that the clutch control arm can drive the clutch push rod.

Check the clutch cover gasket for any damage, bending, or missing sealing material. If any issues are found, replace it with a new clutch cover gasket [4].

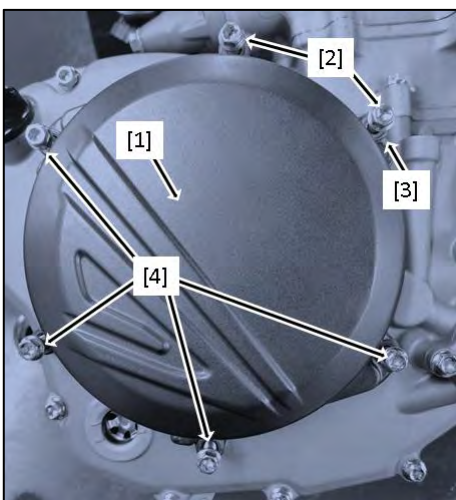

Install the clutch cover [1] and clutch cover gasket onto the right crankcase cover.

Install the following components:

- 2 M6×45 bolts [2], 1 bolt with gasket at chain cavity position [3].
- 4 M6×20 bolts [4]

Tighten the clutch cover bolts in two to three steps in a stagger pattern.

Electronic Fuel Injection (EFI) System

Section 1 Maintenance information	98
Section 2 Position of components	99
Section 3 Introduction of system troubleshooting	100
Section 4 Maintenance and troubleshooting process	104
Section 5 Troubleshoot according to fault codes	104
Section 6 Troubleshoot according to fault phenomena	107
Section 7 Attachment/Fault Code List	110

Maintenance Information

Overview:

- This section introduces UMC's MSE6.0 EFI system equipped with self-diagnostic capabilities. For troubleshooting, please check and rectify faults according to DTC.
- EFI system failures are usually caused by connector disconnection or connector corrosion. Please check the connector before troubleshooting.

Precautions:

- During maintenance, it is forbidden to disassemble the parts of EFI system.
- During maintenance, extreme care shall be exercised on work with electronic components (ECUs, sensors, etc.) to prevent missing. Furthermore, do not touch the pins of electrical components at will to avoid damage caused by electrostatic breakdown.
- Do not remove the connectors of any components of the EFI system from their installation positions without authorization, to avoid accidental damage or foreign matters such as water and oil entering the connectors, which may affect the normal operation of the EFI system.
- When disconnecting or connecting the connector, always ensure the vehicle is in a stalled state to prevent damage to electrical components.
- Since idle speed adjustment is completely completed by EFI system, manual adjustment is not needed. The limit screw of the throttle body has been adjusted at the factory, and the user is not allowed to change its initial position at will.
- This vehicle uses **24-2** teeth trigger signal to identify the speed.

Position of Components

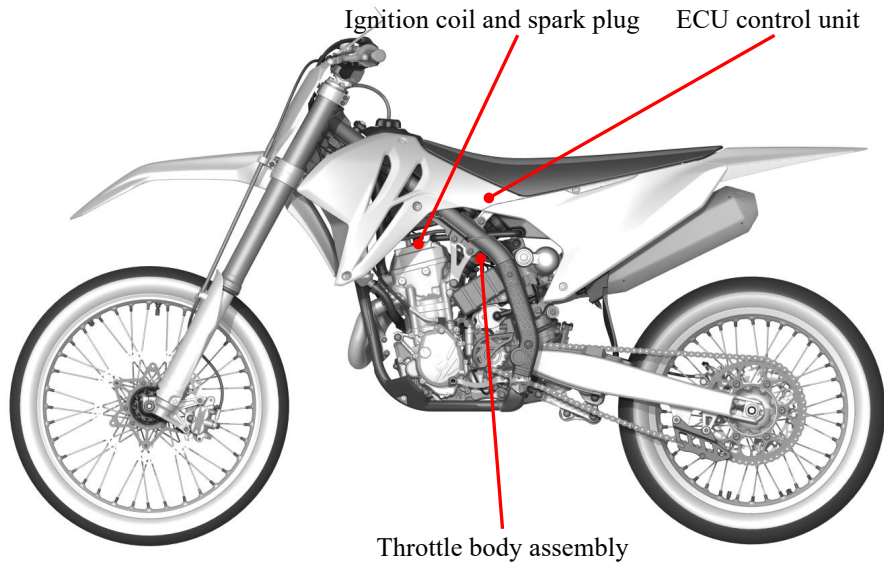

Introduction of System Troubleshooting

On-board diagnosis system (OBD system) refers to the diagnosis system integrated in the engine control system, which can monitor the components that affect exhaust emissions and the main functional states of the engine. It has the function of identifying and storing EFI faults. When repairing vehicles with OBD system, maintenance personnel can quickly and accurately locate the faulty parts through diagnostic instrument, which greatly improves the efficiency and quality of maintenance.

OBD technology involves many brand-new concepts. First of all, some basic knowledge related to OBD technology is introduced in order to facilitate understanding.

Fault information record

The ECU constantly monitors sensors, actuators, related circuits, fault indicators, battery voltages, etc., and even the ECU itself, and detects the reliability of sensor output signals, actuator drive signals and internal signals (such as closed-loop control, coolant temperature, idle speed control, etc.). Once any fault is identified, or any signal value exceeds the normal range, the electronic control unit immediately records the fault information in the fault memory of RAM. Fault information is stored in the form of fault code and displayed in the order of fault occurrence.

Faults can be divided into "current faults" and "historical faults" according to their occurrence time.

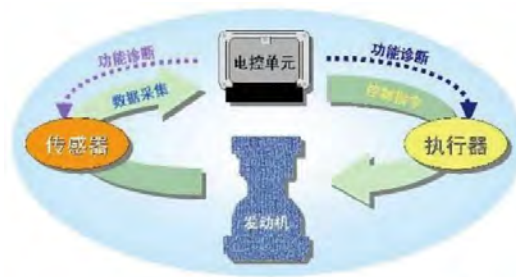

Schematic of Fault Diagnosis of EFI System

Introduction of OBD interface

For keyless power-on, connecting the diagnostic instrument to read faults requires shorting pins L4 and F3 or starting the vehicle. The pins for connecting the engine management system (EMS) are pins 4, 7 and 16 on the OBD diagnostic interface. Pin 4 of the standard diagnostic connector is connected to the battery negative terminal. Pin 7 is connected to pins E3 of ECU, that is, the "K" line of ECU. Pin 16 is connected to the battery positive terminal.

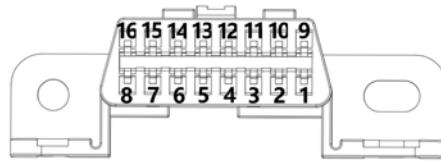

ISO9141-2 Standard Diagnostic Interface Pin Sequence Number

The diagnostic instrument can communicate with the ECU through the "K" line and can read the following information:

- **Version information display**

ECU hardware number, ECU software number.

- **Fault code display**

Intake pressure sensor, IAT sensor, engine water temperature sensor, TP sensor, fuel injector, fuel pump relay, system voltage, ECU, fault lamp, and other fault information.

- **Engine parameter display**

Battery voltage, engine speed, target idle speed, vehicle speed, engine temperature, engine temperature sensor signal voltage, intake air temperature, IAT sensor signal voltage, intake pressure, intake volume, TP sensor signal voltage, throttle opening, relative throttle position, charging time, fuel injection pulse width, ignition advance angle, engine relative load, ambient pressure, altitude correction factor, fuel injection phase, and other parameters.

List of Maintenance Tools



Tool name:

Diagnostic instrument for EFI system:
(XCM-PT100X/PT300X)

Function:

This diagnostic instrument can perform data brushing, read fault and data flow, etc. The diagnostic instrument kit includes diagnostic instrument, USB cable and OBD cable.



Tool name:

Adapter of EFI system

Function:

Check the electrical signal of each ECU pin, check the circuit condition, etc.



Tool name:

Ignition timing lamp

Function:

Check engine ignition timing, etc.



Tool name:

Digital multimeter

Function:

Check the characteristic parameters such as voltage, current and resistance in EFI system.

Tool name:

Vacuum meter

Function:

Check the pressure in the intake manifold.



Tool name:

Cylinder pressure gauge

Function:

Check the cylinder pressure of each cylinder.



Tool name:

Fuel pressure gauge

Function:

Check the pressure of the fuel system for finding out the working conditions of the fuel pump and fuel pressure regulator in the fuel system.

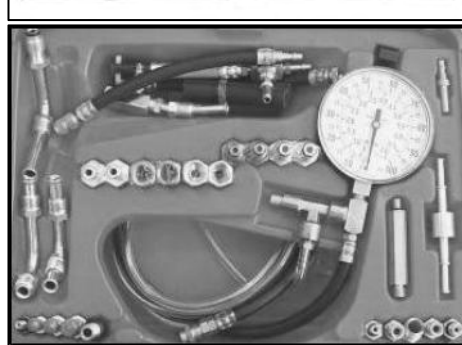

Tool name:

Exhaust gas analyzer

Function:

Checking vehicle exhaust emission is helpful to troubleshooting of EFI system.



Tool name:

Fuel injector cleaning analyzer

Function:

The fuel injector can be cleaned and analyzed.



Maintenance and Troubleshooting Process

Usage of diagnostic instrument

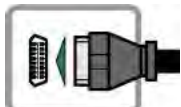

1. Connect the diagnostic instrument to the diagnostic interface.



2. Press the "Electric starter button" to start the vehicle. (keyless power on)



3. Read fault related information (fault code, frozen frame, etc.); read the maintenance manual to confirm the faulty parts and types; make the maintenance plan according to fault related information.



4. Troubleshooting.



5. Turn on the ignition switch again, start the vehicle to read the fault information, and confirm that the fault has been eliminated.

Preliminary check

Before starting the troubleshooting steps based on engine fault codes, a preliminary check shall be performed:

Confirm the existence of the fault phenomena complained by the vehicle owner, and confirm the conditions under which the fault occurs.

Then make a visual inspection:

- Check whether there is leakage in the fuel pipeline;
- Check whether the vacuum pipeline is broken, kinked and connected correctly;
- Check whether the air intake pipeline is blocked, leaked, squashed or damaged;
- Check whether the high-voltage wire of the ignition system is broken and aged, and whether the ignition sequence is correct;
- Check whether the harness ground joint is clean and firm;
- Check whether the sensors and actuator connectors are secured or in poor contact.

Important note: If the above phenomenon exists, the maintenance operation shall be carried out. If not, it will affect the subsequent fault diagnosis and maintenance work.

Troubleshoot according to Fault Codes

This Section introduces the meaning of fault codes used in MSE 6.0 system, the corresponding diagnosis strategy, possible fault causes and fault treatment strategy, which can be used as a reference in the process of vehicle maintenance.

For details of the relevant ECU pins mentioned below, the actual harness diagram of the project may prevail.

Fault code: P0105 Intake pressure sensor signal malfunction

<p>Maintenance tips: The fault has been confirmed and may have the following problems</p> <ol style="list-style-type: none"> 1) ECU detects that the fluctuation amplitude of intake pressure is too small when the sensor signal is running normally; 2) Intake pressure sensor sampling port icing or blockage 3) Intake pressure sensor severely aging. 	<p>Maintenance tips: Check the followings</p> <ol style="list-style-type: none"> 1) Severe intake system leakage; 2) The sampling port of the pressure sensor is mounted downstream of the throttle valve; 3) Reinstall after the ice inside the sensor has melted at room temperature 4) Replace the intake pressure sensor.
---	---

Fault code: P0107 Intake pressure sensor circuit voltage too low

<p>Maintenance tips: The fault has been confirmed and may have the following problems</p> <ol style="list-style-type: none"> 1) detects that the sensor signal circuit is short-circuited to ground 	<p>Maintenance tips: Check the followings</p> <ol style="list-style-type: none"> 1) Resistance between ECU pin and ground
--	--

Fault code: P0108 Intake pressure sensor circuit voltage too high.

<p>Maintenance tips: The fault has been confirmed and may have the following problems</p> <ol style="list-style-type: none"> 1) ECU detects that the sensor signal circuit is short-circuited to the power supply 	<p>Maintenance tips: Check the followings</p> <ol style="list-style-type: none"> 1) Voltage of ECU pin
--	---

Fault code: P0112 IAT sensor signal voltage too low

<p>Maintenance tips: The fault has been confirmed and may have the following problems</p> <ol style="list-style-type: none"> 1) Sensor signal circuit connected to ECU pin is short-circuited to ground 	<p>Maintenance tips: Check the followings</p> <ol style="list-style-type: none"> 1) Measure the resistance between the sensor signal circuit at the ECU pin and ground
--	---

Fault code: P0113 IAT sensor signal voltage too high

<p>Maintenance tips: The fault has been confirmed and may have the following problems</p> <ol style="list-style-type: none"> 1) Sensor signal circuit connected to ECU pin short circuit to ground 	<p>Maintenance tips: Check the followings</p> <ol style="list-style-type: none"> 1) Measure whether the voltage of the sensor signal circuit of ECU pin is normal
---	--

Fault code: P0117 ECT sensor signal voltage is too low

<p>Maintenance tips: The fault has been confirmed and may have the following problems</p> <ol style="list-style-type: none"> 1) Fault code: P0122 Circuit connected to ECU pin short to ground 	<p>Maintenance tips: Check the followings</p> <ol style="list-style-type: none"> 1) Measure the resistance between the ECU pin and ground
---	--

Fault code: P0118 ECT sensor signal voltage too high

<p>Maintenance tips: The fault has been confirmed and may have the following problems 1) Short circuit between circuit connected to ECU pin and other power supply circuit</p>	<p>Maintenance tips: Check the followings 1) Measure whether the voltage connected to the ECU pin is normal</p>
--	---

Fault code: P0122 TP sensor circuit voltage too low

<p>Maintenance tips: The fault has been confirmed and may have the following problems 1) Fault code: P0122 Circuit connected to ECU pin short to ground</p>	<p>Check the followings 1) Measure the resistance between the ECU pin and ground</p>
---	--

Fault code: P0123 TP sensor circuit voltage too high

<p>Maintenance tips: The fault has been confirmed and may have the following problems 1) Short circuit between circuit connected to ECU pin and other power supply circuit</p>	<p>Maintenance tips: Check the followings 1) Measure whether the voltage connected to the ECU pin is normal</p>
--	---

Fault code: P0627 Fuel pump relay control circuit malfunction

Fault code: P0629 Oil pump relay control circuit voltage too high

<p>Maintenance tips: The fault has been confirmed and may have the following problems 1) Open circuit/short circuit to power supply between pump relay control circuit connected to ECU and pump relay. 2) Open circuit between relay and main relay 3) Open circuit of electromagnetic coil of relay</p>	<p>Maintenance tips: Check the followings 1) Measure the resistance or voltage of the fuel pump relay control circuit connected to the ECU 2) Resistance between relay and main relay 3) Resistance between relay pins</p>
---	--

Fault code: P0827 Quick shifter sensor control circuit shorted to ground

<p>Maintenance tips: The fault has been confirmed and may have the following problems 1) Sensor signal circuit connected to ECU pin is short-circuited to ground</p>	<p>Maintenance tips: Check the followings 1) Measure the resistance between the sensor signal circuit at the ECU pin and ground</p>
--	---

Fault code: P0828 Quick shifter control circuit short to power supply

<p>Maintenance tips: The fault has been confirmed and may have the following problems 1) Sensor signal circuit connected to ECU pin short circuit to ground</p>	<p>Maintenance tips: Check the followings 1) Measure whether the voltage of the sensor signal circuit of ECU pin is normal</p>
---	--

Troubleshoot according to fault phenomena

This section introduces the meaning of current fault phenomena, corresponding diagnosis strategies, possible fault causes, and fault treatment strategies, which can be used as a reference in the process of vehicle maintenance.

(1) Start normally but idle at high speed.

Common fault locations: 1. Throttle body and idle bypass air passage; 2. Vacuum pipe; 3. Engine temperature sensor; 4. Ignition timing.

General diagnostic process:

S/N	Operational procedures	Testing result	Subsequent procedures
1	Check whether the accelerator cable is stuck or overtightened	Yes	Adjustment
		No	Next step
2	Check the air intake system and the connected vacuum pipe for air leakage.	Yes	Maintain the air intake system
		No	Next step
3	Remove the engine temperature sensor connector, start the engine, and observe whether the engine is idling too high at this time.	Yes	Maintain the line or replace the sensor
		No	Next step
4	Check whether the mechanical ignition timing of the engine meets the specifications.	Yes	Next step
		No	Maintain the ignition timing
5	Connect the EFI system adapter, power on the ignition switch (ON), and check if the power supply to the L4# pin is normal; check if the ground connection of the M3# pin is normal.	Yes	Diagnostic help
		No	Maintain corresponding lines

(2) When accelerating, the engine speed does not increase or flames out during acceleration.

Common fault locations:

1. Water in fuel 2. Intake pressure sensor and TP sensor; 3. Spark plug; 4. Throttle body and idle bypass air passage; 5. Air intake duct; 6. Fuel injector; 7. Ignition timing; 8. Exhaust pipe.

General diagnostic process:

S/N	Operational procedures	Testing result	Subsequent procedures
1	Check whether the air filter is clogged.	Yes	Maintain the air intake system
		No	Next step
2	Connect the fuel pressure gauge (the connection point is at the front end of the fuel injector inlet pipe), start the engine, and check that the fuel pressure is around 300 kPa at idle.	Yes	Next step
		No	Maintain the fuel supply system
3	Check the spark plug of the cylinder to see whether its model and gap meet the specifications	Yes	Next step
		No	Adjust or replace
4	Remove the throttle body and check for carbon deposition on the throttle body and idle bypass air passage.	Yes	Clean related parts
		No	Next step
5	Check whether the intake pressure sensor, TP sensor and their lines are normal.	Yes	Next step
		No	Maintain the line or replace the sensor
6	Remove the fuel injector and check the fuel injector for leakage or blockage using a special fuel injector cleaning analyzer.	Yes	Replace it in case of failure
		No	Next step

S/N	Operational procedures	Testing result	Subsequent procedures
7	Check the fuel condition to see if the fault phenomenon happens just after refueling.	Yes	Change fuel
		No	Next step
8	Check whether the ignition sequence and ignition timing of the engine meet the specifications.	Yes	Next step
		No	Maintain the ignition timing
9	Check whether the exhaust pipe exhausts smoothly	Yes	Next step
		No	Repair or replace exhaust pipe
10	Connect the EFI system adapter, power on the ignition switch (ON), and check if the power supply to the L4# pin is normal; check if the ground connection of the M3# pin is normal.	Yes	Diagnostic help
		No	Maintain corresponding lines

(3) Slow response when accelerating.

Common fault locations: 1. Water in fuel 2. Intake pressure sensor and TP sensor; 3. Spark plug; 4. Throttle body and idle bypass air passage; 5. Air intake duct; 6. Fuel injector; 7. Ignition timing; 8. Exhaust pipe.

General diagnostic process:

S/N	Operational procedures	Testing result	Subsequent procedures
1	Check whether the air filter is clogged.	Yes	Maintain the air intake system
		No	Next step
2	Connect the fuel pressure gauge (the connection point is at the front end of the fuel injector inlet pipe), start the engine, and check that the fuel pressure is around 330 kPa at idle.	Yes	Next step
		No	Maintain the fuel supply system
3	Check the spark plug of the cylinder to see whether its model and clearance meet the specifications.	Yes	Next step
		No	Adjust or replace
4	Remove the throttle body and check for carbon deposition on the throttle body and idle bypass air passage.	Yes	Adjust or replace
		No	Next step
5	Check whether the intake pressure sensor, TP sensor and their lines are normal.	Yes	Next step
		No	Maintain the line or replace the sensor
6	Remove the fuel injector and check the fuel injector for leakage or blockage using a special fuel injector cleaning analyzer.	Yes	Replace it in case of failure
		No	Next step
7	Check the fuel condition to see if the fault phenomenon happens just after refueling.	Yes	Change fuel
		No	Next step
8	Check whether the ignition sequence and ignition timing of the engine meet the specifications.	Yes	Next step
		No	Maintain the ignition timing
9	Check whether the exhaust pipe exhausts smoothly	Yes	Next step
		No	Repair or replace exhaust pipe
10	Connect the EFI system adapter, power on the ignition switch (ON), and check if the power supply to the L4# pin is normal; check if the ground connection of the M3# pin is normal.	Yes	Diagnostic help
		No	Maintain corresponding lines

(4) Weak acceleration and poor performance.

Common fault locations: 1. Water in fuel 2. intake pressure sensor and TP sensor; 3. Spark plug; 4. Ignition coil;

5. Throttle body and idle bypass air passage; 6. Air intake duct; 7. Fuel injector; 8. Ignition timing; 9. Exhaust pipe.

General diagnostic process:

S/N	Operational procedures	Testing result	Subsequent procedures
1	Check for clutch slippage, low tire pressure, brake drag, and incorrect tire size.	Yes	Repair
		No	Next step
2	Check whether the air filter is clogged.	Yes	Maintain the air intake system
		No	Next step
3	Connect the fuel pressure gauge (the connection point is at the front end of the fuel injector inlet pipe), start the engine, and check that the fuel pressure is around 330 kPa at idle.	Yes	Next step
		No	Maintain the fuel supply system
4	Remove the ignition high-voltage wire, connect a spark plug, and place the spark plug electrode about 5 mm from the engine body. Start the engine and check if the spark plug ignition intensity is normal.	Yes	Next step
		No	Maintain the ignition system
5	Check the spark plug of the cylinder to see whether its model and clearance meet the specifications.	Yes	Next step
		No	Adjust or replace
6	Remove the throttle body and check for carbon deposition on the throttle body and idle bypass air passage.	Yes	Clean related parts
		No	Next step
7	Check whether the intake pressure sensor, TP sensor and their lines are normal.	Yes	Next step
		No	Maintain the line or replace the sensor
8	Remove the fuel injector and check the fuel injector for leakage or blockage using a special fuel injector cleaning analyzer.	Yes	Replace it in case of failure
		No	Next step
9	Check the fuel condition to see if the fault phenomenon happens just after refueling.	Yes	Change fuel
		No	Next step
10	Check whether the mechanical ignition timing of the engine meets the specifications.	Yes	Maintain the ignition timing
		No	Next step
11	Check whether the exhaust pipe exhausts smoothly	Yes	Next step
		No	Repair or replace exhaust pipe
12	Connect the EFI system adapter, power on the ignition switch (ON), and check if the power supply to the L4# pin is normal; check if the ground connection of the M3# pin is normal.	Yes	Diagnostic help
		No	Maintain corresponding lines

Appendix:

1) List of fault codes (PCODE)

S/N	Fault code	Description (UAES)
1	P0105	Intake pressure sensor voltage (signal) fault
2	P0106	Intake pressure sensor signal abnormal
3	P0107	Intake pressure sensor circuit voltage too low
4	P0108	Intake pressure sensor circuit voltage too high
5	P0112	IAT sensor signal voltage too low
6	P0113	IAT sensor signal voltage too high
7	P0117	ECT sensor circuit voltage too low
8	P0118	ECT sensor circuit voltage too high
9	P0122	TP sensor circuit voltage too low
10	P0123	TP sensor circuit voltage too high
11	P0627	Oil pump relay control circuit malfunction
12	P0629	Oil pump relay control circuit voltage too high.
13	P2300	Ignition coil for cylinder 1 short to ground
14	P0827	Quick shifter sensor circuit short to ground
15	P0828	Quick shifter sensor control circuit short to ground

Fuel System

Section 1 Maintenance instructions	112
Section 2 Position of components	113
Section 3 Fuel tank assembly	114
Section 4 Fuel pressure release	114
Section 5 Quick connector disassembly	115
Section 6 Quick connector installation	116
Section 7 Fuel pressure addition	117
Section 8 Fuel pump unit	117
Section 9 Fuel pump unit assembly/fuel tank installation	118
Section 10 Inspection and adjustment of accelerator free stroke	120
Section 11 Air filter assembly	121
Section 12 Cleaning and replacement of air filter sponge element	122
Section 13 Throttle body assembly and intake pipe	123
Section 14 Throttle valve body assembly	124
Section 15 Fuel rail and injector	125

Maintenance Instructions

Overview:

- Bending or kinking the control cable can affect the operation and may cause the cable to bind or wind, resulting in loss of vehicle control.
- Please work in a well-ventilated area. Smoking in a place where gasoline is stored can cause a fire or explosion.
- Release the fuel pressure in the system before disconnecting the fuel supply hose.
- Do not turn the throttle flap from fully open to fully close after removing the throttle, as this may cause erratic idle speed.
- Seal the intake port with tape or a clean cloth to prevent dirt and foreign materials from entering the engine after the throttle body is removed.
- Keep dust and debris out of the throttle bore and air passages after the throttle body is removed. Clean them using compressed air, if necessary.
- Do not loosen or tighten any nuts or screws on the throttle body painted with torque markers, as this may cause throttle valve and idle speed control malfunctions.
- Do not apply commercial carburetor detergent on the inside of the throttle bore.

Position of Components

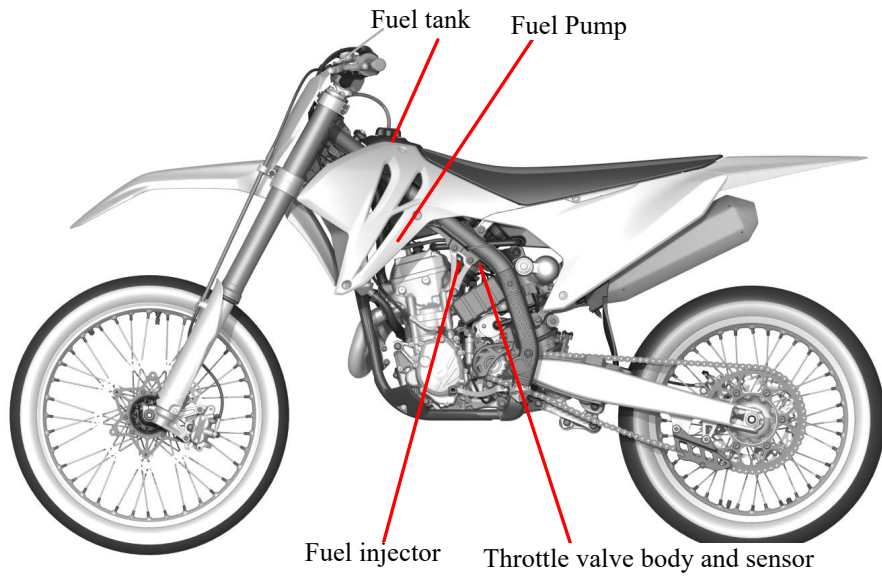

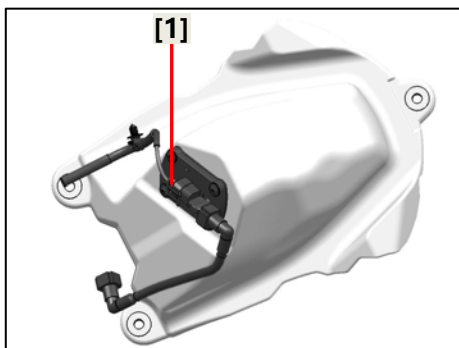
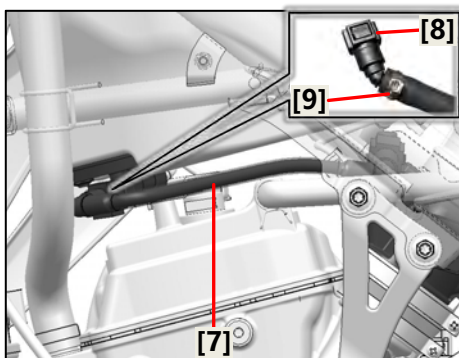
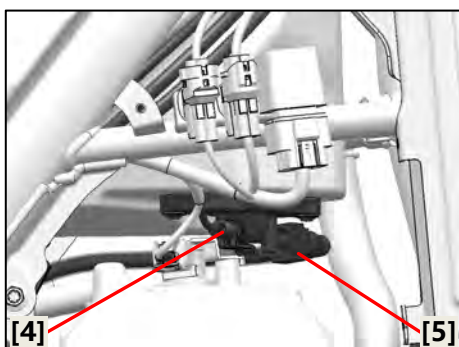
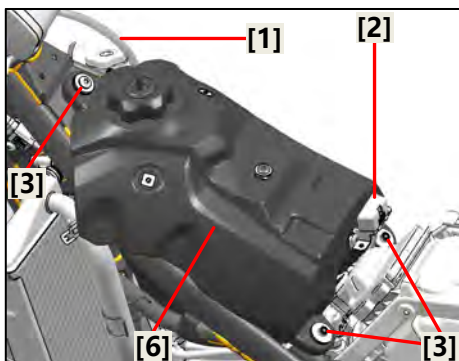

※ **Fuel tank assembly**

1. Use a pump to extract gasoline from the fuel tank.

Notes

- Although the gasoline in the fuel has been removed, residual gasoline may still exist, so be careful when removing fuel hoses.
- Do not use tools to remove or install the fuel supply hose, connectors, and fuel pipes to avoid damage.

Note

- Clamp the fuel tank vent hose with a pipe clamp.

2. Disassembly

- Seat cushion assembly
- Front fuel tank trims - left and right

See "Frame, body trim, exhaust system" on page 45 for details.

3. Disassembly

- Fuel tank vent pipe [1];
- OBD detection interface [2];
- Bolt [3];
- Disconnect the fuel pump harness connector [4];
- Disconnect the fuel hose quick connector [5];
- Fuel tank assembly [6].

Notes

- Do not hang the fuel tank from the fuel supply hose
- Cover the frame with a rag to prevent damage to the frame.
- If the quick connector and its surroundings are dirty, please clean them.

4. Inspection

Gasoline pipeline

- Check the fuel hose/quick connector/single ear stepless clamp for any looseness, damage or leakage. Check if there are any of the following situations
Squeeze/loosen → Connect correctly.
Crack/damage/leak → Replace.

Torque:

Front and rear mounting points of fuel tank

10 N·m (1.0 kgf·m, 7.0 lbf·ft)

※ **Fuel pressure release**

Notes

- Before disconnecting the fuel hose, release the system pressure as follows.

1. Disconnect the power supply harness connection plug [1] of the fuel pump unit.
2. Start the engine and let it idle until it stops to release the fuel pressure in the fuel hose.

※ Quick connector



- When disassembling, cover the fuel hose connector with a cloth. When disassembling the hose, residual pressure in the fuel pipeline may cause gasoline to spray out.

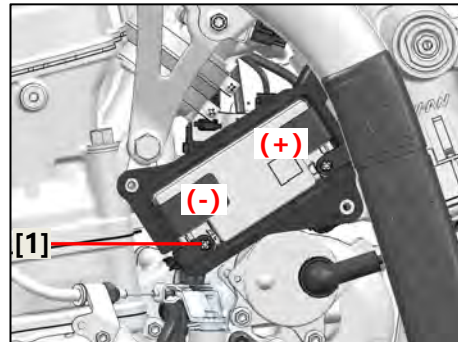

Disassembly

1. Release the fuel pressure
2. Disconnect the battery negative (-) terminal bolt [1].
3. Place a cloth at the fuel line quick connector.
4. Press the fuel hose to release button [2] and disconnect the quick connectors [3] from the fuel pump unit and the fuel rail connectors respectively.

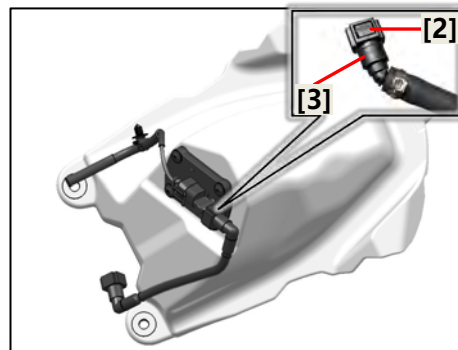

Notes

- Although the gasoline in the fuel has been removed, residual gasoline may still exist, so be careful when removing fuel hoses.
- Clean around the quick connector before disconnecting the fuel hose, ensuring no dust enters the fuel system.

Note

- Cover the disconnected connector [4] and fuel connector end [5] with plastic bags to prevent damage and foreign materials from getting in.

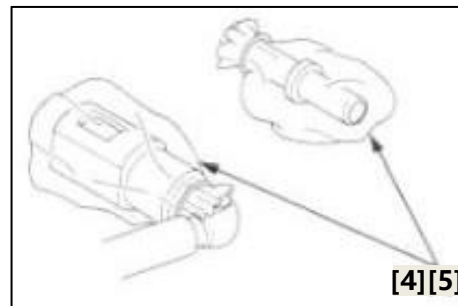

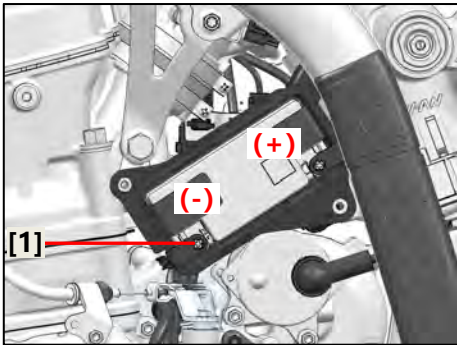
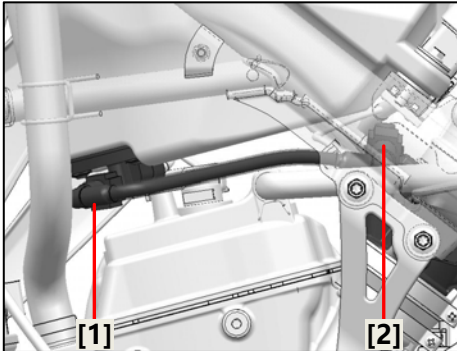

※ Quick connector

Installation

1. Connect the quick connectors [1], [2] to the fuel pump unit connector and the injector connector, respectively, while holding the quick connector housing until a "click" sound is heard.
2. If it is not easy to connect, apply a small amount of machine oil to the fuel connector end, making sure the connection is secure and the quick connector is firmly locked in place; visually inspect and pull the connector housings.
3. Connect the battery negative (-) cable [3] and tighten the battery terminal bolt to the specified torque.

Torque:

Battery terminal mounting bolts

5.0 N·m (0.5 kgf·m, 3.7 lbf·ft)

Notes

- Do not reuse kinked or damaged fuel supply hoses, as this could cause a fuel leak.
- Clean around the quick connector before installing the fuel hose, ensuring no dust enters the fuel system.

※ **Fuel pressure addition**

1. Connect the power supply harness plug [1] of the fuel pump.
2. Temporarily install the fuel tank onto the frame.
3. With the throttle fully closed, pull the clutch handle all the way down and press the starter switch. The engine will start by increasing the fuel pressure.
4. Turn off the engine and check if there is any leakage in the fuel pipeline.

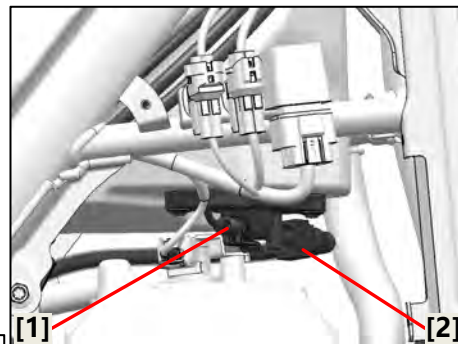
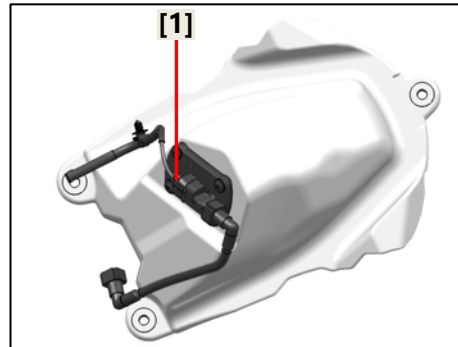

※ **Fuel pump unit**



- Although the gasoline in the fuel has been removed, residual gasoline may still exist, so be careful when removing fuel hoses.

1. Disassemble
 - Disconnect the fuel pump harness connector
 - Fuel quick connector [2];
 - Bolt [3];
 - Fuel pump [6];
 - Rubber seal [7].

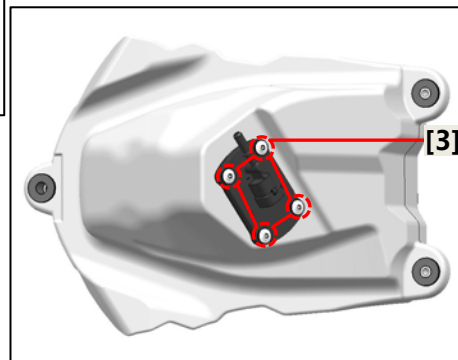

Notes

- When removing the fuel pump rubber seal, ensure there is no dust around the seal and the tank mounting surface, and prevent dust from entering the fuel system.

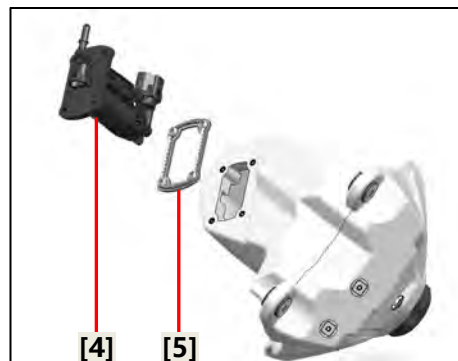

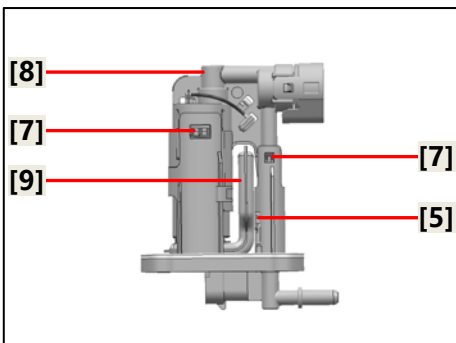
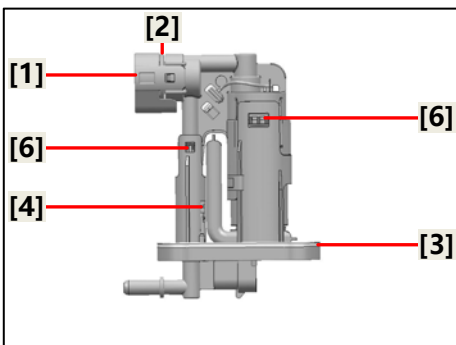
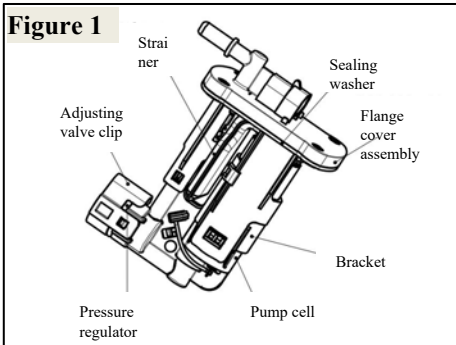

※ **Fuel pump unit assembly**

As shown in Figure 1: Diagram of the fuel pump unit assembly.

1. Disassembly

- Regulating valve clip [1];
- Pressure regulator [2];
- Gasket [3].

Notes

- Check if the fuel filter (strainer) is clogged, damaged, or aged, and replace if necessary.
- Check if the fuel pump rubber gasket is damaged or aged, and replace if necessary.

2. Disassembly

- Disconnect harnesses [4] and [5];
- Release the clips [6] and [7];
- Pump core[8] and strainer[9].

Notes

- After replacing the strainer component, please correctly lay out the harness with black and red wires.
- Avoid using tools when disassembling to prevent damage to the fuel pump unit.

※ **Fuel tank installation**

1. Fuel Pump

Install the following components:

- Fuel pump [1];
- Rubber gasket [2];
- Bolt [3].

Notes

- When installing the fuel pump rubber gasket, ensure there are no foreign objects between the gasket and the fuel tank mounting surface.
- Position the fuel pump outlet (interface) toward the left side of the vehicle.

Note

- Rubber seals require a small amount of grease.
- As shown in the right figure, tighten the fuel pump bolts in the correct sequence indicated by the arrows.

Torque:

Fuel pump mounting bolts

4.0 N·m (0.4 kgf·m, 3.0 lbf·ft)

2. Fuel tank

- Connect the quick connector [4];
- Connect the connector [5];
- Install the front connecting bolt [6] of the fuel tank;
- Install the rear connecting bolt [7] of the fuel tank;
- Install the OBD interface [8];
- Remove the clamp [9] of the fuel tank vent hose.

Notes

- Be careful not to twist or bend the fuel hose.
- Check whether the quick connector of the fuel hose is correctly installed.
- The installation positions of the fuel tank buffer rubber are shown in the figure below.

Torque:

Front and rear mounting points of fuel tank

10 N·m (1.0 kgf·m, 7.0 lbf·ft)

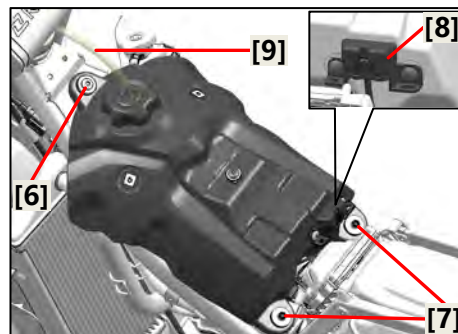
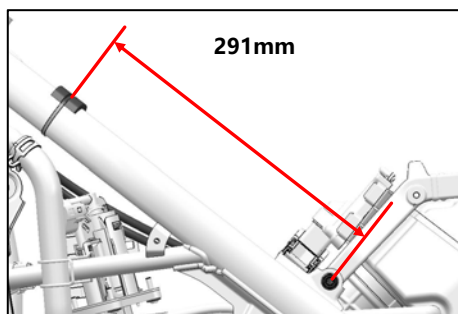
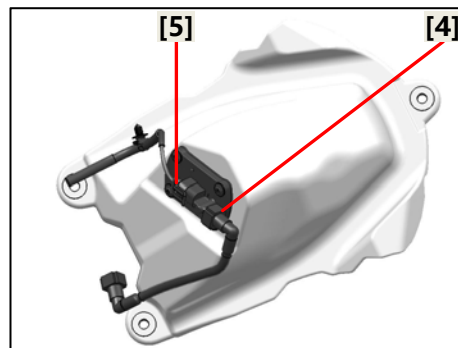
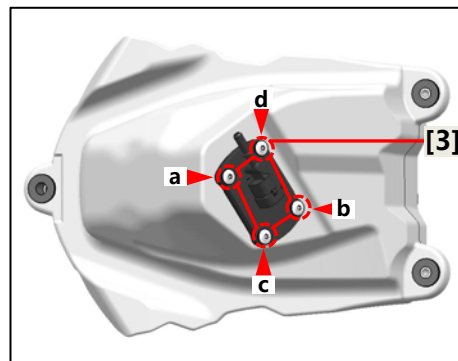
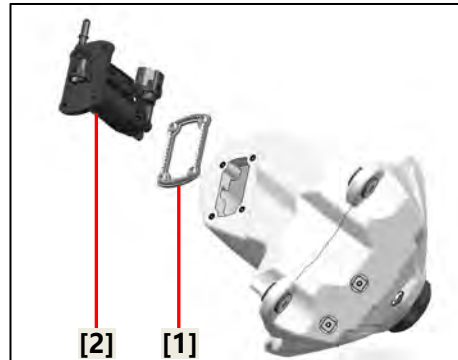

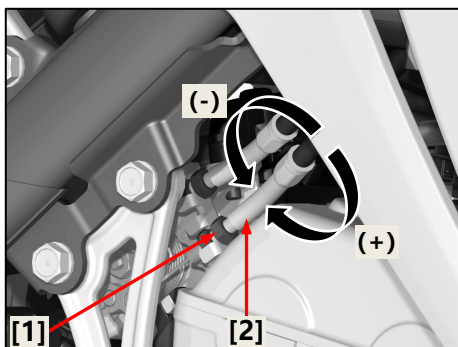
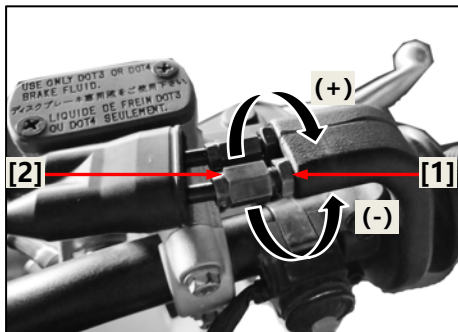
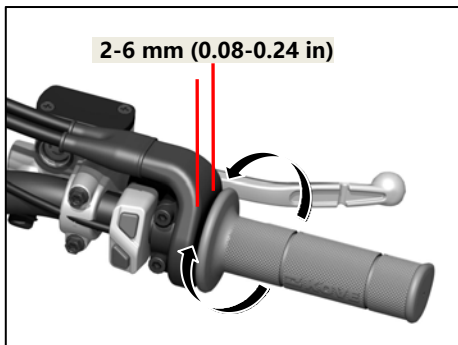

※ **Inspection and adjustment of accelerator free stroke**

Check whether the throttle cable is aged, damaged or kinked. Turn the accelerator handle and check that the throttle opens smoothly and closes automatically in any steering position.

If the accelerator handle does not rotate well, check that the cables are wired correctly, the accelerator is clean with recommended lubricant (engine oil or proper cable lubricant), and the accelerator drum rotates normally.

If Ok, but the throttle does not rotate well, replace the accelerator cable (oil inlet and oil return).

Measure the free play at the accelerator handle flange.

Free play: 2-6mm (0.08-0.24 in)

1. Fine-tune on the accelerator side

Loosen the lock nut [1] and turn the adjuster [2]. Turning the adjuster in the (-) direction will reduce the free play, and turning the adjuster in the (+) direction will increase the free play.

After adjustment, hold the adjuster and tighten the locking nut.

If the correct free play cannot be obtained despite turning the regulator to the end, turn it back in the (+) direction until it lightly touches the end, make one turn in the (-) direction, and then make more adjustments on the throttle side.

Nut [1] torque:

5.0 N·m (0.5 kgf·m, 4.0 lbf·ft)

2. Adequately adjust on the throttle side

Loosen the accelerator cable adjuster lock nut [1] and turn the adjuster [2] in the (-) direction to reduce the free clearance and in the (+) direction to increase the free clearance.

After the adjustment, hold the adjuster and tighten the locking nut of the inlet accelerator cable adjuster to the specified torque.

Torque:

4.0 N·m (0.4 kgf·m, 3.0 lbf·ft)

(The oil inlet and oil return cables are subjected to the same adjustment)

Notes

- Re-check whether the accelerator rotates smoothly or not.

※ **Air filter assembly**

Disassembly/installation

Disassemble the following parts:

- Clamp [1];
- Exhaust pipe [2];
- Subframe upper bolts [3][4];
- Subframe upper bolts [5][6];
- Subframe and air filter assembly [7];
- Screw [8];
- Air filter assembly [9].

The installation sequence is reversed from the removal sequence.

Inspection

As shown in Figures 2 and 3:

- Check if the mounting bolts and clamps of the air filter tank are loose.

Loose → Tighten.

- Replace the air filter element according to the maintenance schedule or whenever

Too dirty or damaged → Replace.

Note

- If you frequently ride in wet or dusty areas, maintain the air filter more frequently.

Torque:

Air filter and subframe mounting bolt

5.0 N·m (0.5 kgf·m, 4.0 lbf·ft)

Connecting bolt between subframe and main frame

34 N·m (3.4 kgf·m, 18 lbf·ft)

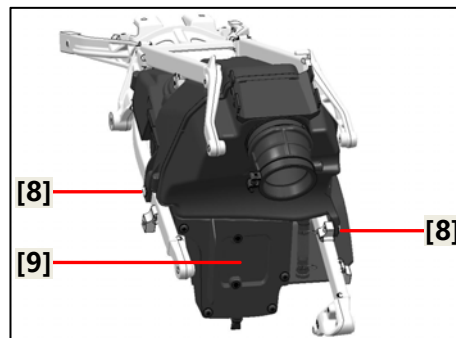
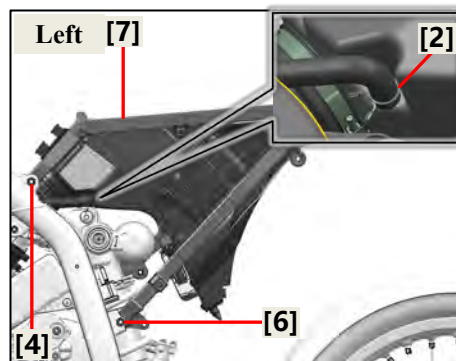
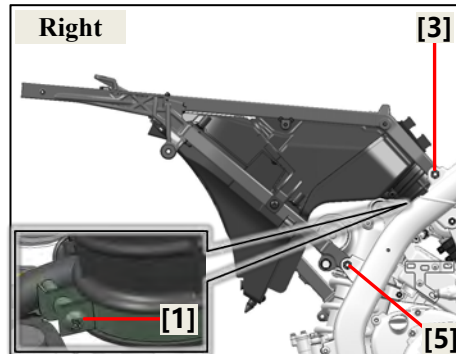

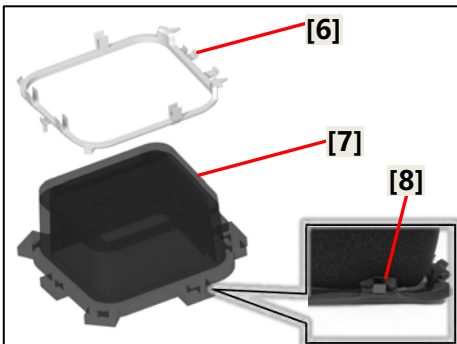
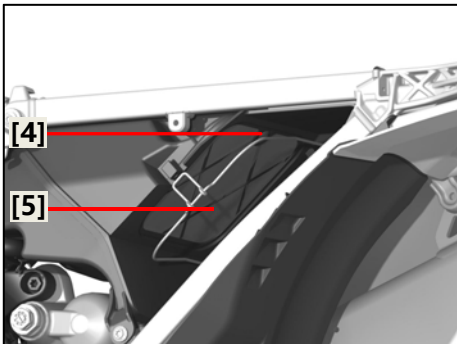
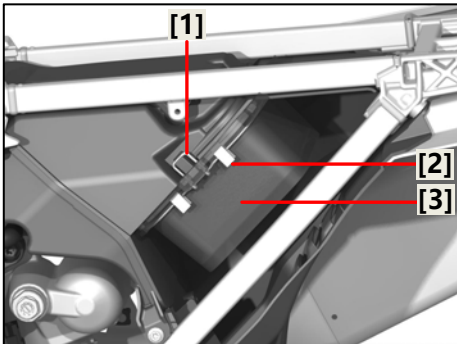

※ Cleaning and replacement of air filter sponge element

④. Sponge filter element and filter element bracket

Disassembly/installation

Disassemble the following parts:

- Release the retaining spring [1] of the sponge filter element;
- Sponge filter element [2] and element bracket [3];
- Remove the screws [4] for fixing the metal strainer;
- Take out the metal strainer [5].

The installation sequence is reversed from the removal sequence.

Note

- Remove the sponge filter element [7] from the filter element bracket [6].

Notes

- Be careful not to damage the sponge filter element [8].

Thoroughly clean the sponge filter element [1] in a cleaning solvent, and then clean it in hot water with detergent or soap solution.

Ensure that there is no dirt or dust in the air filter element. Clean it again if necessary. After cleaning, squeeze out the moisture from the air filter element and let it dry thoroughly.

Notes

- Since gasoline or low-flash-point solvents are highly flammable, it is prohibited to use them to clean the air filter sponge filter element.

Apply 50cm³ of KOVE foam air filter oil or equivalents to the inner side of the sponge filter element.

Put the air filter sponge filter element into a plastic bag and evenly apply the air filter oil with both hands.



- Do not use engine oil on the sponge filter element.

※ **Throttle body assembly and intake pipe**

1. Disassembly

As shown in Figure 1

- Three-in-one sensor connection plug [1];
- Fuel injector connection plug [2].

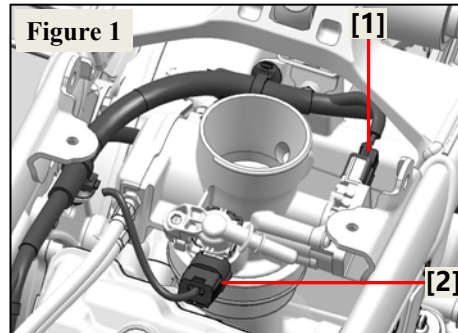

2. Disassembly

As shown in Figures 2 and 3

- Nut [1];
- Screw [2];
- Cover [3];
- Accelerator cable [4];
- Clamp [5];
- Throttle body assembly [6].

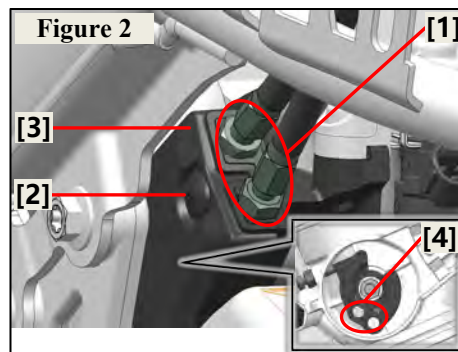

3. Disassembly

As shown in Figure 4

- Bolt [1];
- Intake pipe assembly [2].

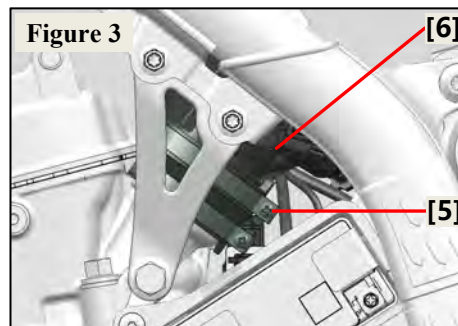

4. Inspection

- Check if the installation position of the hoop [6] is correct
- Incorrect position → adjustment → correct installation.

- Check the throttle intake pipe
- Crack/damage → Replace.

5. Installation

The installation sequence is reversed from the removal sequence.

Torque:

Throttle cable A/B (throttle end)

4.0 N·m (0.4 kgf·m, 3.0 lbf·ft)

Intake pipe clamp locking bolt

4.0 N·m (0.4 kgf·m, 3.0 lbf·ft)

Cover and throttle valve

2.0 N·m (0.2 kgf·m, 1.5 lbf·ft)

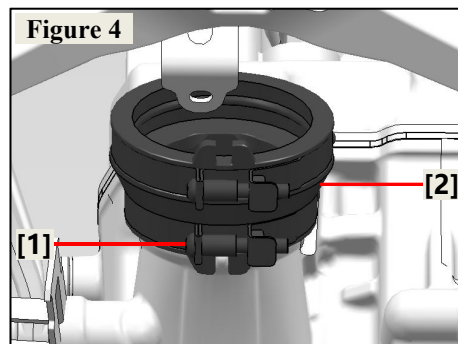

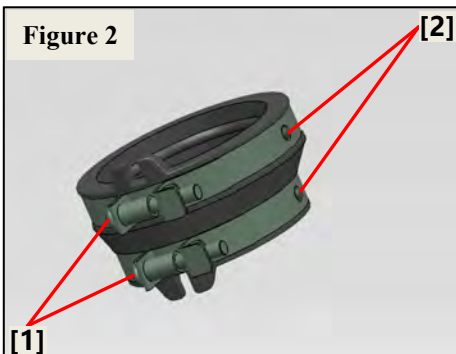
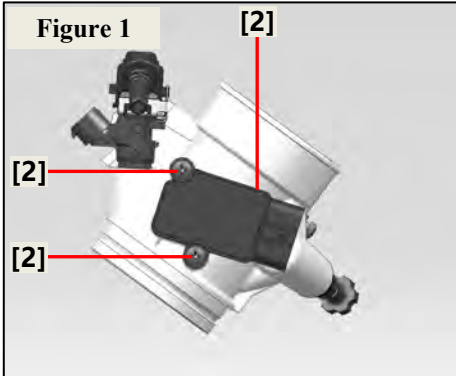
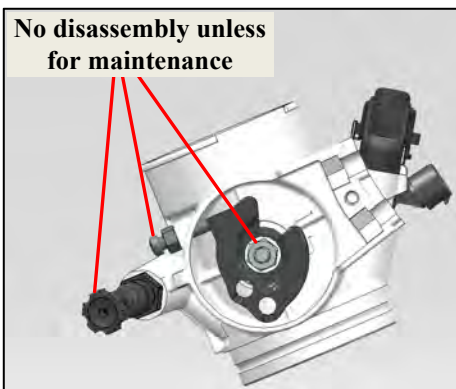
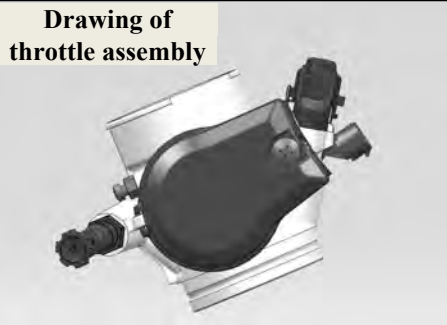

※ **Throttle valve body assembly**



- The throttle body is pre-assembled at the factory and must not be disassembled in any manner other than as specified in this manual.
- Do not loosen or tighten the nuts and screws marked with torque values, as loosening or tightening them may cause malfunctions of the throttle body.

Three-in-one sensor

1. Disassembly

As shown in the Figure 1:

- Screw [1]
- Three-in-one sensor[2];

2. Inspection

- Check the O-ring on the three-in-one position sensor for deterioration or damage.

Notes

- Do not use a wire brush or other tools to remove carbon deposits, otherwise the side throttle body will be damaged.
 - Do not allow carbon deposits or other foreign matters to enter the throttle body passage or the gap between the throttle valve shaft and the throttle valve body.
 - Replace the seal/ring with a new one.
3. Cleaning
- Throttle Valve Body

Notes

- Clean the throttle body with special carburetor solvent.
- Do not use corrosive cleaning fluid.
- Do not spray cleaning solvent directly on plastic parts, sensors or seals.
- Do not directly push open the throttle flap.

4. Installation

The installation sequence is reversed from the removal sequence.

Note

- As shown in Figure 2, install the pipe clamp on the intake pipe with the screw head [1] facing the left side of the vehicle, and align the groove [2] with the lug.

Torque:

Three-in-one sensor mounting screws

2.0 N·m (0.2 kgf·m, 1.5 lbf·ft)

※ **Fuel rail and injector**



- Check the fuel injector in an area without flammable materials and ensure good ventilation. Ensure no smoking or use of electric tools near the fuel injector.
- Ensure no smoking or use of electric tools near the fuel injector. Be cautious when disconnecting the fuel hose. Place a container or cloth under the hose to catch any spilled fuel. Always clean up any spilled fuel immediately.
- Before removing the fuel injector, turn the main switch to "OFF" and disconnect the negative battery terminal from the battery.

1. Disassembly

Screw [1]

- Fuel rail [2].
- Fuel injector clamp [3];
- Fuel injector [4];
- Fuel injector O-ring [5];
- Fuel rail O-ring [6].

2. Inspection

- Fuel injector

Stuck → replace and check the fuel pump/fuel system.

Accumulation → Replace.

Damage → Replace.

3. Inspection

- Fuel injector resistance

See "Electrical Components" on page 170 for details.

4. Installation

The installation sequence is reversed from the removal sequence.

Torque:

Fuel rail mounting bolt

8.0 N·m (0.8 kgf·m, 6.0 lbf.ft)

Notes

- Always use a new O-ring.
- When checking the fuel injector, do not allow any foreign matter to enter or adhere to the fuel injector, fuel rail or O-ring.
- Be careful not to twist or squeeze the O-ring when installing the fuel injector.
- Install the original fuel injector cap and bolt, please use cleaning solvent to remove the white paint mark. Otherwise, paint chips on the screw thread may prevent the bolt from locking to the specified torque.

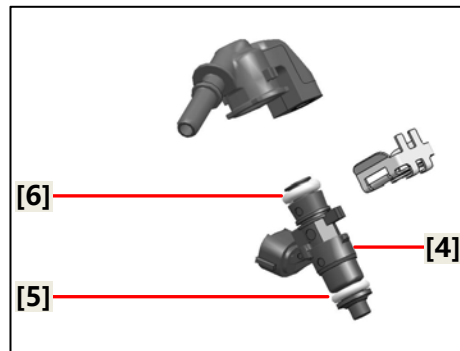
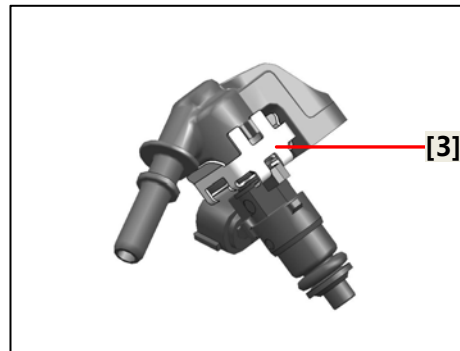
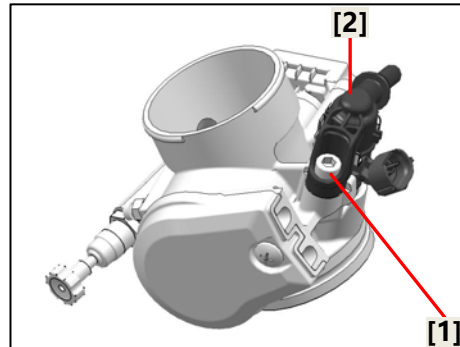

Front Wheel, Suspension, Steering

Section 1 Maintenance instructions	128
Section 2 Troubleshooting	128
Section 3 Position of components	129
Section 4 Front wheel assembly	130
Section 5 Front shock absorber	131
Section 6 Replacement of front shock absorber oil	132
Section 7 Front shock absorber wear ring	134
Section 8 Steering handlebar and components (left and right)	135
Section 9 Steering handle	137
Section 10 Lower handlebar clamp	137
Section 11 Lower connecting plate and steering stem assembly	137

Maintenance instructions

Overview:

- In maintenance of front wheel, front shock absorber and steering stem, dedicated work bench or equivalent means shall be used to support the motorcycle.
- Do not operate the brake handle after the front and rear wheels are removed.
- After installing the front wheel, check the braking operation with the brake handle.

Troubleshooting

Inflexible steering

- Insufficient tire pressure
- Tire damage and deformation
- Over-tight adjusting nut on steering stem
- Wear or damage of bump steering retainer
- Steering stem bending

Turning to one side or not going straight

- Axle bend
- Incorrect installation of wheel
- Wear or damage of wheel bearing
- Damaged or loose steering bearing
- Frame deformation and damage

Front wheel shaving

- Bending and deformation of rim edge
- Tire damage and deformation
- Wear or damage of wheel bearing
- Axle slack
- Unbalanced tires and wheels

Wheels are difficult to turn

- Damaged wheel bearing
- Axle deformation
- Brake failure

Soft suspension

- Low tire pressure
- Metal fatigue of absorber spring
- Low liquid level in shock absorber
- Incorrect specification of absorber oil (low viscosity)

Hard suspension

- High tire pressure
- Deformation of absorber components
- High liquid level in shock absorber
- Incorrect specification of absorber oil (high viscosity)
- Blockage in absorber oil passage

Abnormal noise from front suspension

- Loose absorber fastener
- Incorrect specification of absorber oil (low viscosity)
- Wear of slider on front absorber bushing

Position of Components

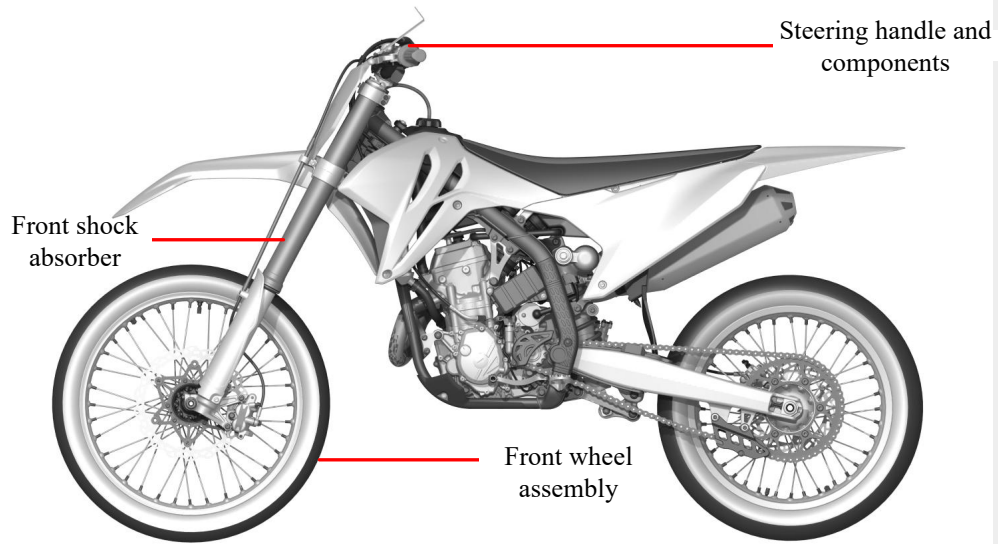

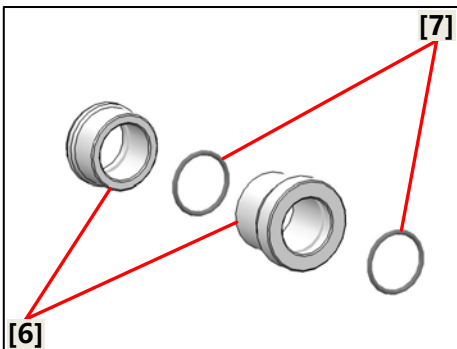
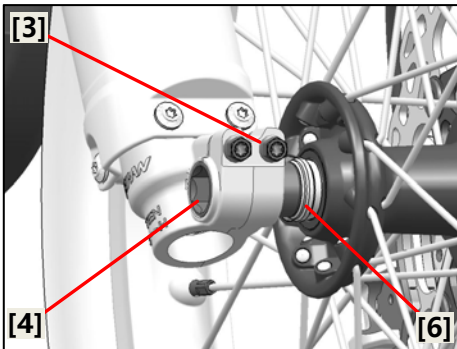
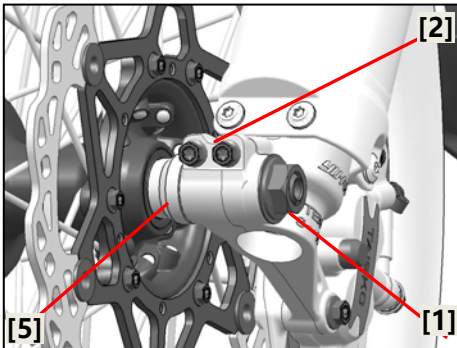
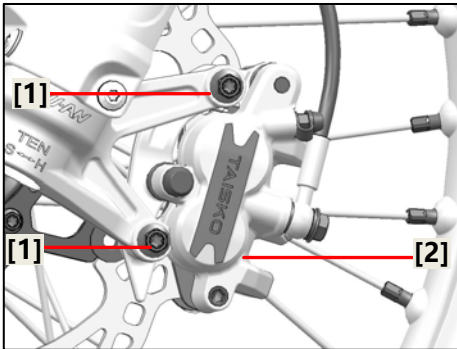

※ **Front wheel assembly**

1. Stand the vehicle on a flat ground.



- The vehicle shall be supported firmly without the danger of overturning.

2. Disassembly

- Bolt [1];
- Front brake caliper [2].

Notes

- Do not hang the front brake caliper on the brake hose.
- Do not operate the hand brake lever after removing the brake caliper.

3. Disassembly

- Remove the front wheel axle locking nut [1];
- Loosen the left and right shock absorber bottom cylinder locking bolts [2] and [3];
- Lift the front wheels off the ground;
- Pull out the front wheel axle [4] and remove the front wheel assembly along with the bushings [5] and [6].

4. Inspection

- O-ring [7]
- Damage → Replace.

5. Installation

The installation sequence is reversed from the removal sequence.

Note

- Place the wheel between the front shock absorbers, carefully align the axle holes and insert the front wheel axle from the left side. Pre-tighten the shock absorber bottom cylinder shaft locking bolt to a torque of 5N·m.
- Tighten the front wheel axle locking nut to the specified torque.
- Torque.
- With the front brake engaged, move the front shock absorber up and down several times to seat the axle and check the operation of the brake.
- Tighten the left and right shock absorber bottom cylinder bolts to the specified torque.
- Torque:

Front wheel axle locking (nut)

88 N·m (8.8 kgf·m, 65 lbf·ft)

Front shock absorber bottom cylinder locking bolt

22 N·m (2.2 kgf·m, 16 lbf·ft)

Notes

- During installation, apply grease to the groove between the main and auxiliary lips of the wheel hub bearing seal and to the O-ring inside the bushing. (Silicone grease)

※ **Front shock absorber**

1. Stand the vehicle on a flat ground.



- The vehicle shall be supported firmly without the danger of overturning.

2. Disassemble the front shock absorber

- Front brake caliper [1]

See p "Hydraulic Brake System" on page 151 for details.

- Front wheel assembly [2]

See "Front Wheels, Suspension, Steering" on page 127 for details.

- Front shock absorber trim [3]

See "Frame, Body Trim, Exhaust System" on page 45 for details.

Notes

- Do not hang the brake caliper on the brake hose.
- Do not operate the hand brake lever after removing the brake caliper.



- Support the front shock absorber first before loosening the mounting bolts connecting the upper and lower plates.

3. Disassembly

Loosen the upper connecting plate locking bolt [1], firmly support the shock absorber, loosen the lower connecting plate mounting bolt [2], and pull the shock absorber outer cylinder [3]. Then rotate it downward to remove it from the bores of the upper and lower connecting plates until it is fully extracted.

4. Installation

The installation sequence is reversed from the removal sequence.

Torque:

Upper connecting panel mounting bolts

Mounting bolt for lower connection plate

22 N·m (2.2 kgf·m, 16 lbf·ft)

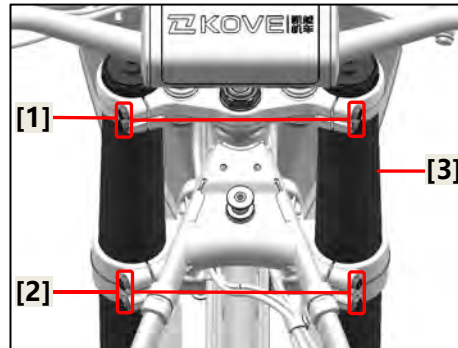
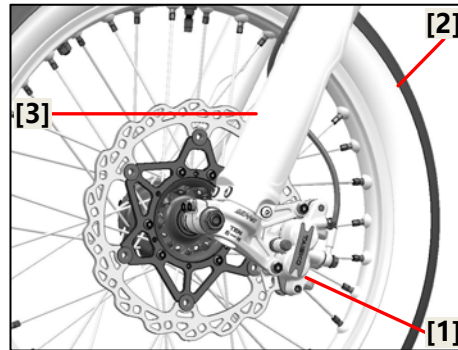

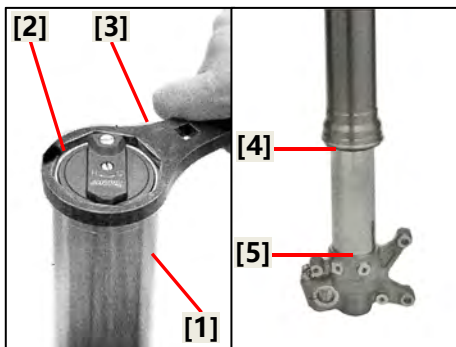
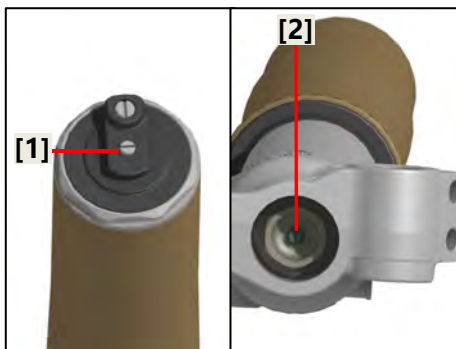

※ Replacement of front shock absorber oil

The following procedure for removal of the front shock absorber applies to both left and right.

1. Disassemble:

- Steering handle and components;
See "Front Wheels, Suspension, Steering" on page 127 for details.
- Number plate (front panel);
See "Frame, Body Trim, Exhaust System" on page 45 for details.
- Loosen the locking bolt [1] of the upper bracket;
- Loosen the upper cover assembly [2] of the shock absorber adjustment inner chamber.

Notes

- If you plan to replace the front shock absorber oil, loosen the shock absorber adjustment inner chamber cover assembly.
- Do not remove the upper adjustment cover assembly of the front shock absorber inner chamber. Use a special tool to loosen the upper cover assembly of the front shock absorber inner chamber.

Tools:

Locking nut wrench, 50mm

Notes

- Remove the inner chamber cover of the reducer.

2. Disassemble:

- Front shock absorber;
See "Front Wheels, Suspension, Steering" on page 127 for details.

Notes

- Record the current positions of the compression damping adjuster [1] and the rebound damping adjuster [2].

Turn the compression and rebound damping adjusters counterclockwise and set them to the softest positions.

- Hold the outer hose [1] and use a special tool to remove the upper cover [2] of the front shock absorber from the outer hose;

- Slowly slide the outer hose down until the dustproof seal [4] is on the bottom cylinder [5].

Tools:

Locking nut wrench, 50mm [3]

- Compress the outer hose [1] several times to drain the shock absorber oil from it, and then remove the O-ring [2] from the shock absorber.

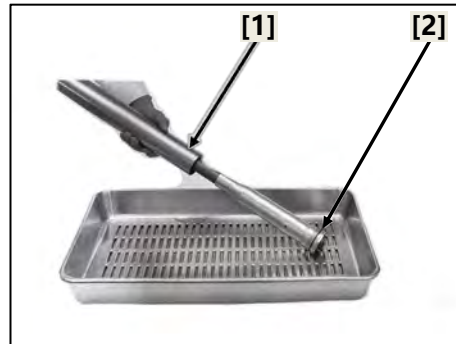

3. Add

Pour the recommended shock absorber oil into the fork tube [1].

Recommended shock absorber oil:
AMSOIL

Thunder High-Performance Shock
Absorber Oil

Shock absorber oil (viscosity: 10W)

Standard shock absorber oil total capacity:
510±3ml

Shock absorber inner chamber (damper):
260±3 mL

Shock absorber outer chamber (spring
chamber) 350±3ml

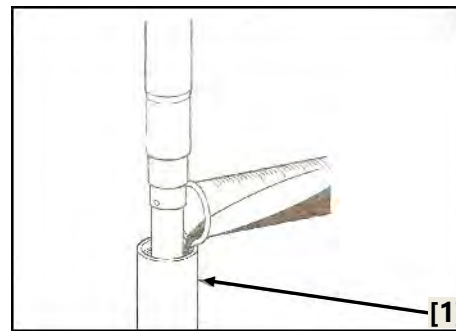

Notes

- Pump the fork tube slowly several times to remove the trapped air at the lower part of the fork hose.

- Apply the recommended shock absorber oil to the new O-ring [1] and install the O-ring on the front shock absorber [2].

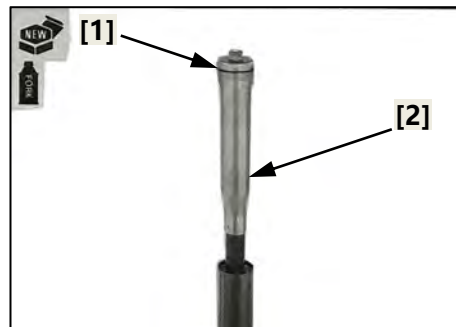

- Slowly pull up the outer hose [1].
Use a special tool to temporarily tighten the upper adjustment cover [2] of the shock absorber into the front fork tube.

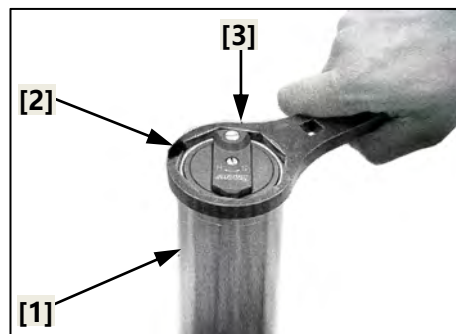

Tools:

Locking nut wrench, 50mm [3]

Torque

**Front shock absorber spring chamber
adjustment cap**

30 N·m (3.0 kgf·m, 22 lbf·ft)

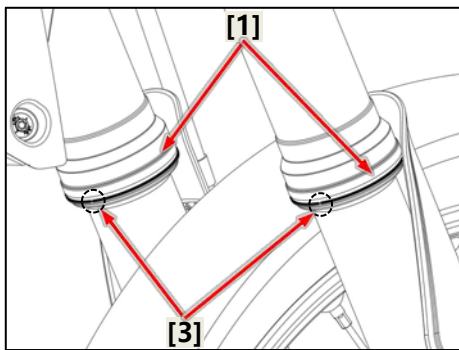
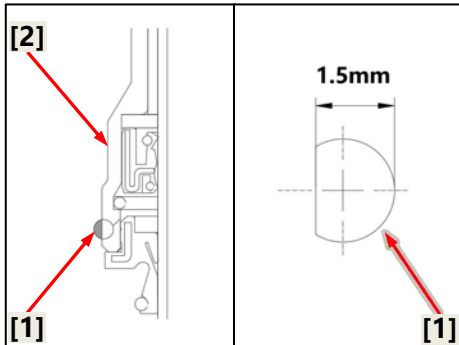

※ **Front shock absorber wear ring**

Check the operation of the front shock absorber by operating the front brake and compressing the front shock absorber several times.

Check the entire front shock absorber assembly for signs of leakage, damage, or loose fasteners. Check if the decorative protector and the dustproof seal ring of the front shock absorber are clean, free of dirt or dust. Remove the dirt or dust accumulated at the bottom of the front shock absorber seal.

Check the wear ring [1] for wear or damage.

If the wear ring is less than 1.5 mm or flush with the front fork tube [2], replace the wear ring.

Ensure that the end clearance [3] of the wear ring faces backward.

※ **Steering handlebar and components (left and right)**

1. Stand the vehicle on a flat ground.



- Support the vehicle firmly so as not to turn over.

2. Disassembly

- Impact-resistant cable sheath (chest protector) [1].

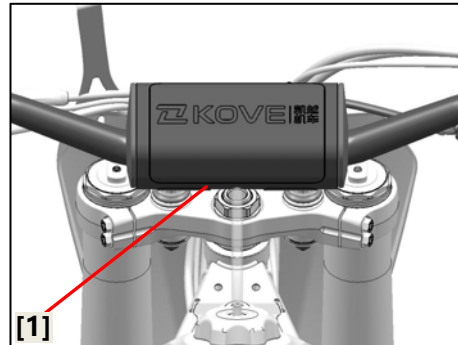

3. Disassembly

Left steering handlebar assembly

- Screw [1]
- Handlebar grip [2].
- Steering handlebar left switch [3]; See "Frame, body trim, exhaust system" on page 45 for details.
- Screw [4];
- Handle fixing bracket [5];
- Clutch handle [6].

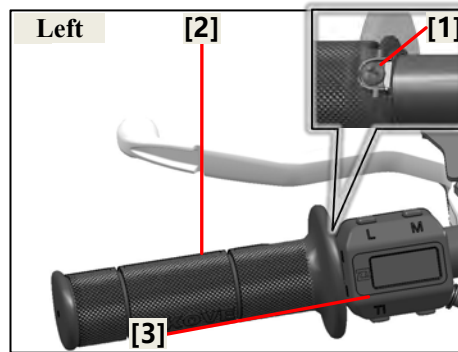

Note

- Install the clutch handle fixing socket by aligning its mating surface with the marking point [a] on the left side of the handlebar.
- Install the handle fixing socket with the arrow [b] facing upward.

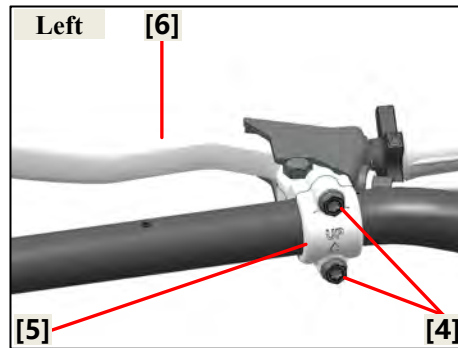

Torque:

Clutch handle mounting bolt

8.0 N·m (0.8 kgf·m, 6.0 lbf·ft)

Steering handlebar - left switch mounting screw

3.0 N·m (0.3 kgf·m, 2.2 lbf·ft)

Handlebar grip mounting screw

7.0 N·m (0.7 kgf·m, 5.2 lbf·ft)

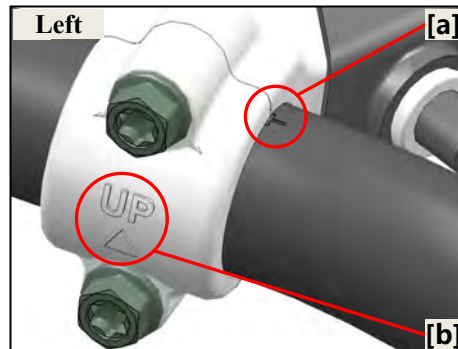

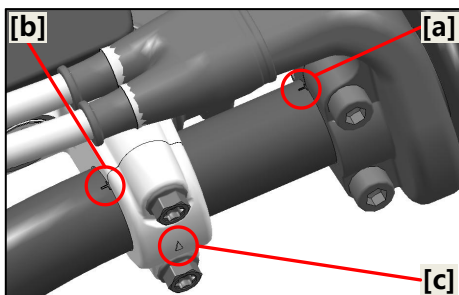
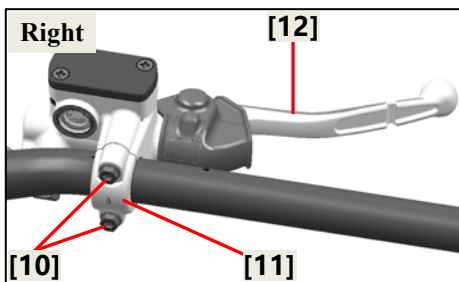
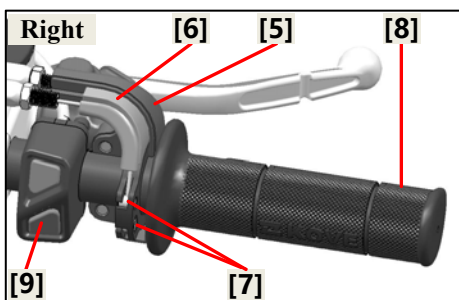
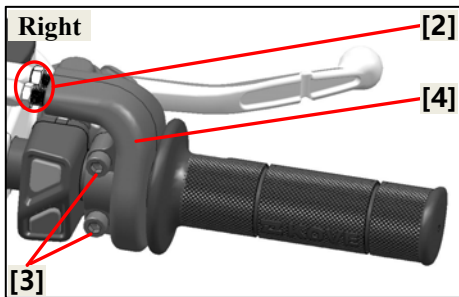
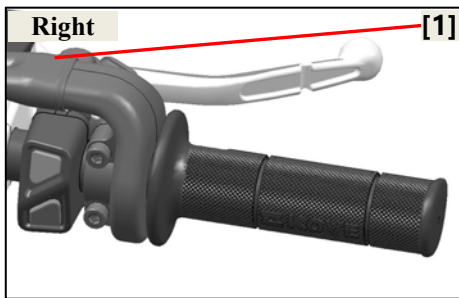

4. Disassembly

Right steering handlebar assembly

- Rubber grommet [1];
 - Adjustable cable assembly bolt[2];
 - Bolt [3];
 - Front cover [4];
 - Rear cover [5];
 - Guide block [6];
 - Throttle cable [7];
 - Handlebar grip assembly [8];
 - Right steering handlebar switch [9];
- See "Frame, Body Trim, Exhaust System" on page 45 for details.
- Bolt [10];
 - Socket [11];
 - Front hand brake lever [12].

5. Installation

The installation sequence is reversed from the removal sequence.

Notes

Align the joint surface of the refueling socket with the marking point [a] on the right side of the steering handlebar for installation.

·Align the joint surface of the front brake handlebar fixing socket with the marking point [b] on the right side of the handlebar for installation.

- Install the front brake handlebar fixing socket with the arrow [c] facing upward.

Torque:

Front brake pump mounting bolts

8.0 N·m (0.8 kgf·m, 6.0 lbf.ft)

Oiler mounting screw

8.0 N·m (0.8 kgf·m, 6.0 lbf.ft)

Steering handlebar - right switch mounting screw

4.0 N·m (0.4 kgf·m, 3.0 lbf.ft)

※ **Steering handlebar and upper/lower connecting plates, steering stem assembly**

1. Place the vehicle on the workbench.



- Support the vehicle firmly so as not to turn over.

2. Disassemble:
Steering handle

- 4 bolts [1]
- Steering handlebar clamp [2]
- Steering handlebar [3]

3. Disassemble:

- Nut and flat gasket [4]
- Steering handlebar lower socket [5]
- Buffer rubber [6]

Notes

- The handlebar buffer rubbers are rubber products. If they are deformed or damaged, please replace them in time.

4. Disassemble:

- Upper connecting plate
- Steering stem locking bolt and flat gasket [7]
- Bolt [8]
- Upper connecting plate [9]

5. Disassemble:

- Upper connecting plate and steering stem assembly
- Remove the 4-slot nut [10]
- Upper dustproof washer [11]
- Lower connecting plate and steering stem assembly [12]

6. Install:

The installation sequence is reversed from the removal sequence.

Torque:

Upper and lower sockets on the steering handlebar
Lower end of double-ended thread bolt to upper connecting plate

22 N·m (2.2 kgf·m, 16 lbf·ft)

Upper end of double-ended threaded bolt to lower socket of steering handlebar

30 N·m (3.0 kgf·m, 22 lbf·ft)

Fastening nut between upper bracket and steering stem

108 N·m (10.8 kgf·m, 80 lbf·ft)

Steering stem locking 4-slot nut

First torque to 40N·m, then loosen and torque to 10N·m, and finally back off by 1/4 turn

Notes

- Head tube pressure bearing: (tapered roller bearing)
Model: Upper 32005 Lower 32006
Brand: (C&U Bearing).

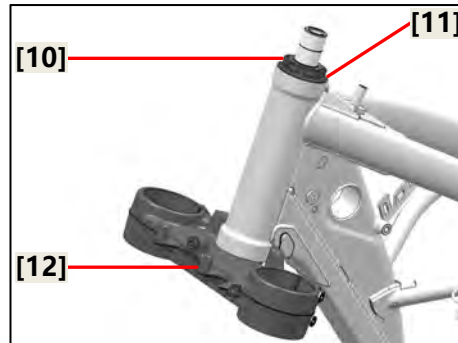
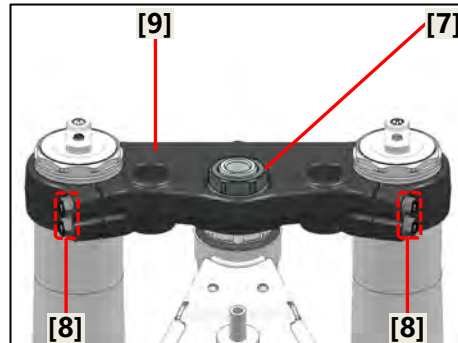
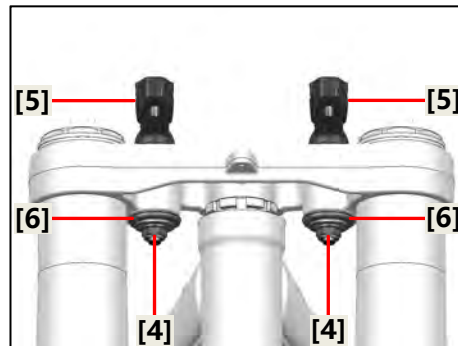
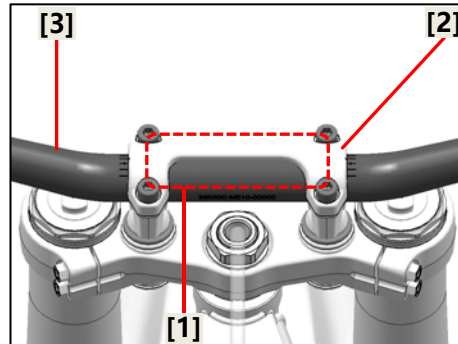

Rear wheel/Suspension

Section 1 Maintenance instructions	140
Section 2 Troubleshooting	140
Section 3 Position of components	141
Section 4 Rear wheel assemblies	142
Section 5 Inspection and replacement of wheels and tires	143
Section 6 Inspection of rim damage and runout	143
Section 7 Replacement of tires	144
Section 8 Guide sprocket and guide chain slider	144
Section 9 Rear shock absorber, suspension components, and rear swingarm	145
Section 10 Rear shock absorber assembly	147
Section 11 Inspection and adjustment of slack of drive chain	148
Section 12 Inspection, cleaning and lubrication of transmission chain	149
Section 13 Replacement of drive chain	150
Section 14 Drive/driven sprockets	150

Maintenance Instructions

Overview:

- In maintenance of rear wheel, suspension and relevant components, dedicated work bench or equivalent means shall be used to support the motorcycle.
- Do not operate the brake pedal after the rear wheel is dismounted.
- After installing the rear wheel, step on the brake pedal to check the brake operation.
- All suspension pivots and mounting points can only be replaced with original KOVE bolts and nuts.

Troubleshooting

Turning to one side or not going straight

- Non-uniform adjustment of drive chain adjuster
- Axle bending
- Wear of swingarm axle
- Wheel jitter
- Tire deformation
- Wear or damage of wheel bearing
- Improper tightening of axle
- Damage to rear swingarm pivot bearing
- Improper tightening of suspension assembly bolts
- Unbalanced tires and rims

Wheels are difficult to turn

- Damaged wheel bearing
- Curved axle
- Over-tight drive chain
- Brake resistance

Soft suspension

- Low tire pressure
- Improper adjustment of suspension
- Metal fatigue of absorber spring
- Oil leakage from shock absorber

Hard suspension

- High tire pressure
- Improper adjustment of suspension
- Bending of shock absorber rod
- Damage to suspension or slewing pivot bearing
- Improper tightening of slewing pivot

Noise from rear suspension

- Loose suspension fasteners.
- Wear or damage of suspension pivot bearing
- Shock absorber failure

Position of Components

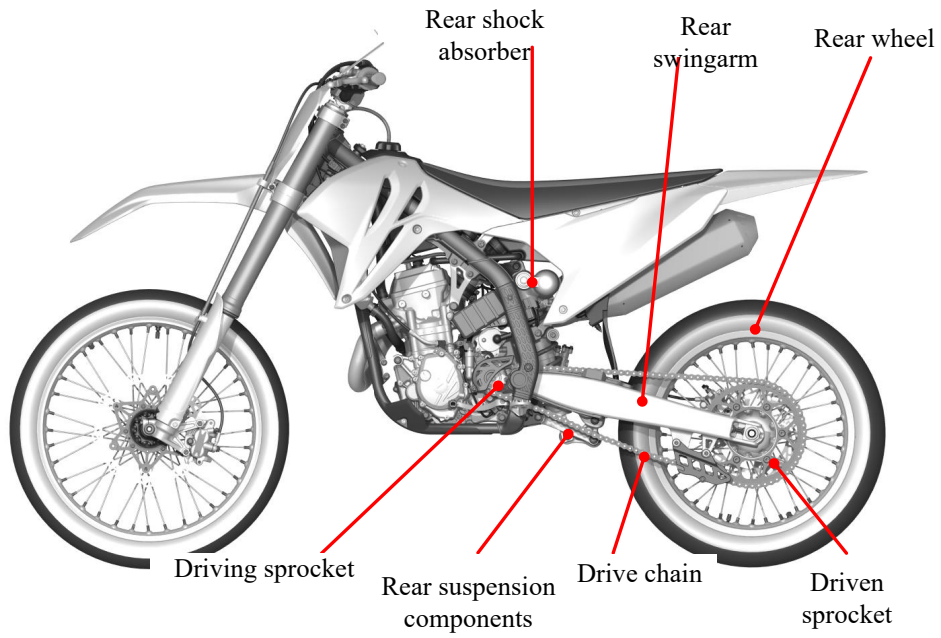

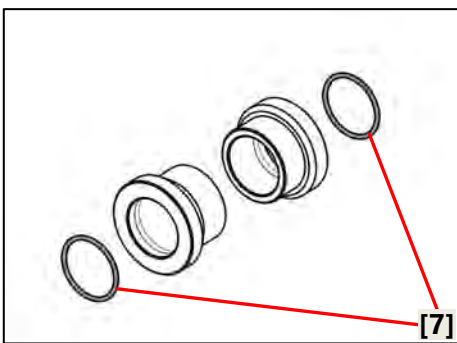
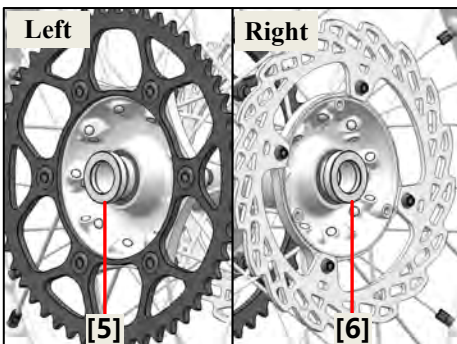
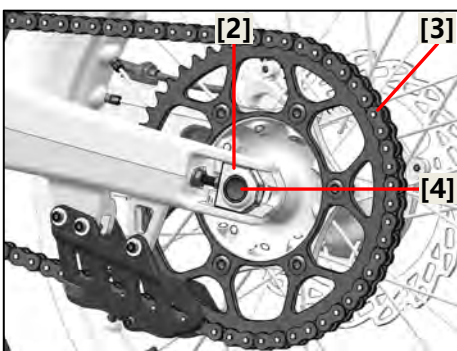
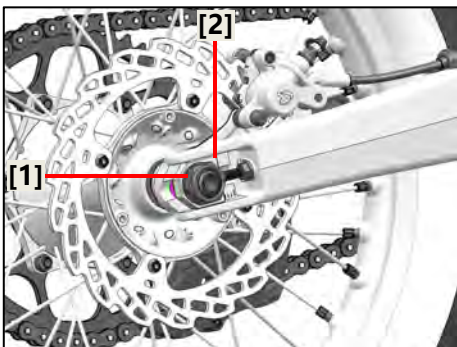

※ **Rear wheel assemblies**

1. Stand the vehicle on a flat ground.



- Support the vehicle firmly so as not to turn over.

2. Disassembly

- Rear wheel locking nut [1];
- Withdraw the chain adjusters on both the left and right sides [2] so that the wheel can move forward continuously.
- Push the rear wheel forward to disengage the drive chain [3] from the large sprocket;
- Hold the rear wheel and remove the rear wheel axle [4];
- Rear wheel assembly.

3. Disassembly

- Rear wheel T-shaped bushing - Left side [5];
- Rear wheel bushing - Right side [6].

4. Inspection

- O-ring seal ring [7] inside the T-type bushing.
- Damage → Replace

Notes

- Do not operate the brake pedal after the wheel is disassembled.

5. Installation

The installation sequence is reversed from the removal sequence.

Torque:

Rear wheel axle locking nut

128 N·m (12.8 kgf·m, 95 lbf·ft)

Notes

- When installing the rear wheel, don't let the brake caliper fall out of the rear swing arm boss or damage the brake pad.
- During installation, apply grease to the seal ring in the T-shaped bushing located in the groove between the main and auxiliary lips of the wheel hub bearing seal.
- Apply grease for lubrication.

※ **Inspection of wheels and tires**

Check tires for cuts, embedded nails, or any other signs of damage. Check that the front and rear wheels are properly installed. Ensure the tire is in a cold state, then use a tire pressure gauge to check the tire pressure.

Tire pressure:

Front: 100 kPa (1.0 kgf/cm², 15 psi)

Rear: 100 kPa (1.0 kgf/cm², 15 psi)

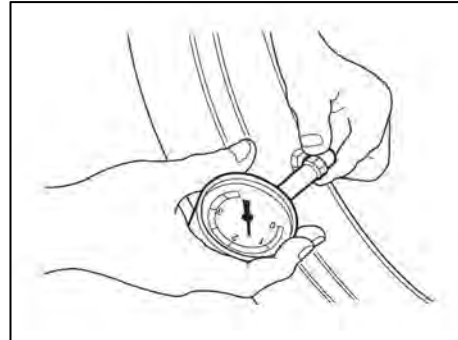

☆ Adjust the tire pressure appropriately based on the specific usage requirements.

※ **Inspection of rim damage and runout**

1. Inspection

Check the wheel rim [1] and spokes [2] for damage. Use a spoke wrench [3] to tighten any loose spokes to the specified torque. Tighten the rim tire clip nuts [4] to the specified torque.

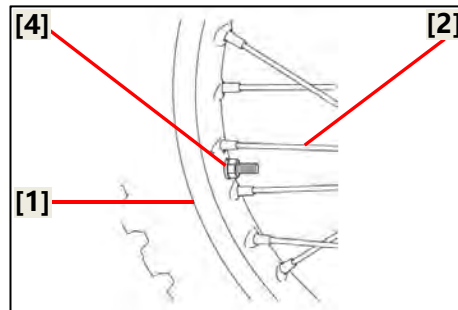

Tools

Front wheel: Spoke wrench, 6.0mm

Rear wheel: Spoke wrench, 7.0mm

Torque:

Front/rear wheel spokes:

6 N·m (0.6 kgf·m, 4.4 lb·ft)

Front/rear tire clip locking nuts:

12 N·m (1.2 kgf·m, 9.0 lb·ft)

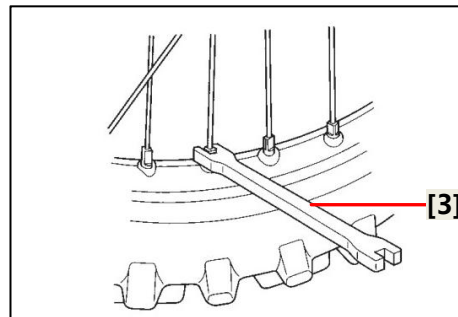

2. Measurement

- Radial wheel rim runout [1]
- Axial wheel rim runout [2]

If the specified limit is exceeded → replace.

Wheel rim runout:

Limit value:

Front wheel: Radial: 1.0 mm

Axial: 1.0 mm

Rear wheel: Radial: 1.0 mm

Axial: 1.0 mm

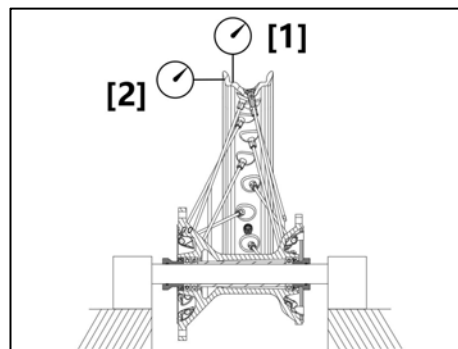

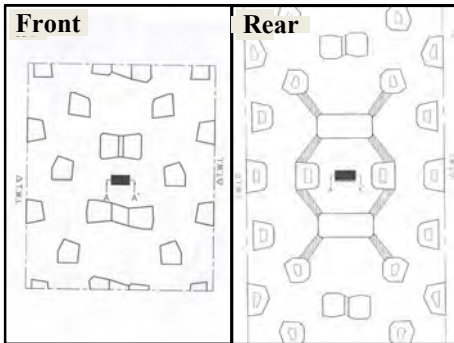

Tire specifications:

Front wheel	80/100-21 M/C 51M	
	Chengxin/CST	CM736
Rear wheel	100/90-19 M/C 57M	
	Chengxin/CST	CM739
Type	Ordinary inner tube (butyl rubber)	

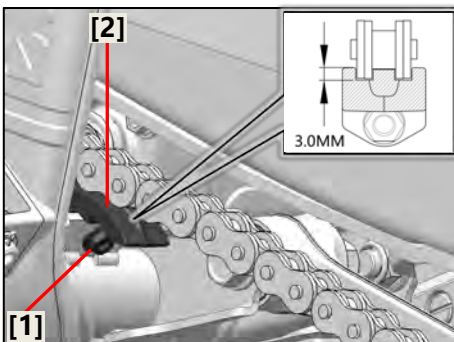
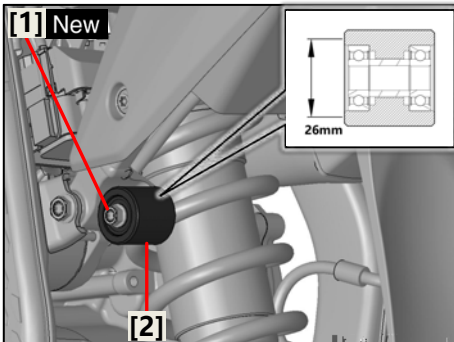

※ **Replacement of tires**

KOVE's tires provide outstanding handling, braking, durability, and comfort in various riding conditions.



- Installing improper tires on your motorcycle can affect handling and stability, Which may result in an accident or injury.
- Make sure to use the sizes and types of tires recommended in this manual.
- Driving a motorcycle with worn tires can lead to danger. Tires must be replaced immediately when the tread reaches the limit of wear.

- When replacing tires, use original tires or equivalent tires of the same size.
- The tread pattern, rated speed, and load range shall be the same as the original tires. When replacing the tires, please replace the inner tubes with new ones.
- The old inner tubes may be stretched and could fail if installed in new tires.

Notes

- Tire wear limit marks at Δ T.W.I. mark on sidewall and center of tire

※ **Guide sprocket and guide chain slider**

Disassembly/installation

Disassemble the following parts:

- Screw [1]
- Guide sprocket [2].

Inspection

Check if the sprocket (black) is excessively worn or stuck.

Wear limit not less than:

Diameter: 26 mm

Notes

- Each time you disassemble the guide sprocket bolt, replace it with a new one.
- The installation sequence is reversed from the removal sequence.

Torque:

Guide sprocket and subframe

22 N·m (2.2 kgf·m, 16 lbf·ft)

Chain slider and frame

10 N·m (1.0 kgf·m, 7.0 lbf·ft)

※ **Rear shock absorber, suspension components, and rear swingarm**

1. Stand the vehicle on a flat ground.



- Support the vehicle firmly so as not to turn over.

2. Disassembly

- Drive chain [1];

See "Rear wheels, suspension" on page 139 for details

- Frame trim - left and right [2];

See "Frame, body trim, exhaust system" on page 45 for details.

- Rear wheel assembly [3].

See "Rear wheels, suspension" on page 139 for details

3. Disassembly

- Rear brake caliper [4];
- Brake hose clip [5].

Note

- When removing or installing the rear swingarm, be careful with the rear brake hose to avoid bending or damage.

4. Disassembly

Suspension components

- Bolt [6];
- Bolt [7];
- U swingarm [8].

5. Disassembly

- Bolt [9];
- Bolt [10];
- Triangular cradle [11];
- Swingarm axle (nut) [12];
- Rear swingarm [13];
- Bolt [14];
- Rear shock absorber [15].

6. Installation

The installation sequence is reversed from the removal sequence.

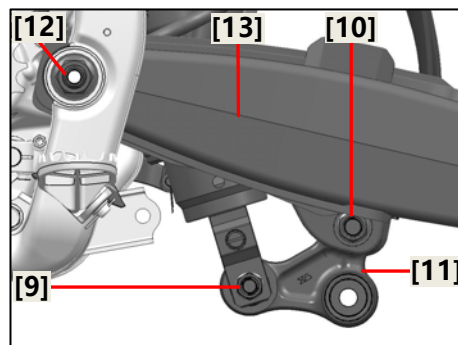
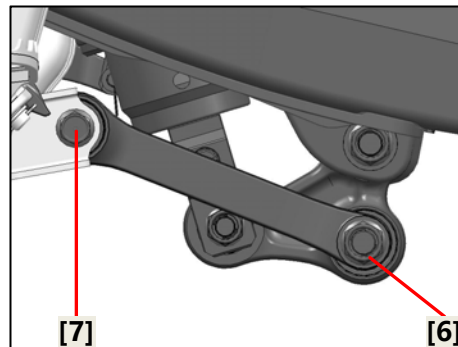
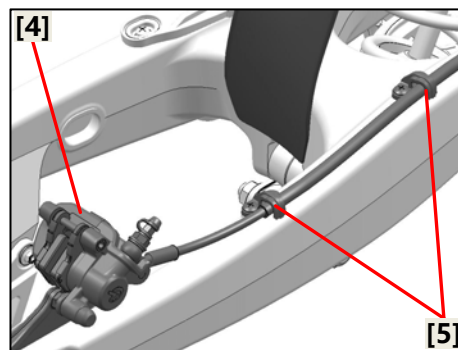
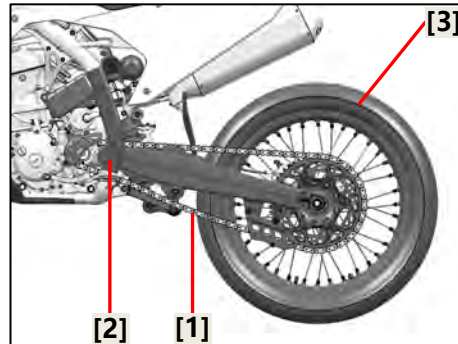

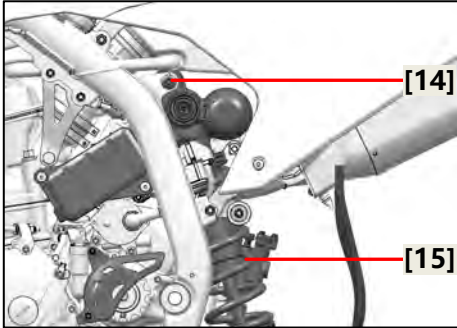

Torque :

U swingarm to frame connection

Swingarm to triangular cradle connection

U swingarm to triangular cradle connection

60 N·m (6.0 kgf·m, 44 lbf·ft)

Upper rear shock absorber to frame connection

Lower rear shock absorber to triangular cradle connection

44 N·m (4.4 kgf·m, 33 lbf·ft)

Swingarm axle locking nut

88 N·m (8.8 kgf·m, 65 lbf·ft)

Mounting bolt of the oil pipe clip

5.0 N·m (0.5 kgf·m, 3.7 lbf·ft)

Notes

- Apply a very small amount of grease to the groove between the main and auxiliary lips of the swingarm bearing seal during installation.
- Lubricate the swingarm with high-temperature extreme pressure composite lithium grease (UNIVERSAL SU-T330Y or equivalent).
- The decomposed diagram of the suspension pivot assembly and swingarm pivot is shown in the figure below.

The following is the decomposed diagram of the pivot and swingarm axle assembly.

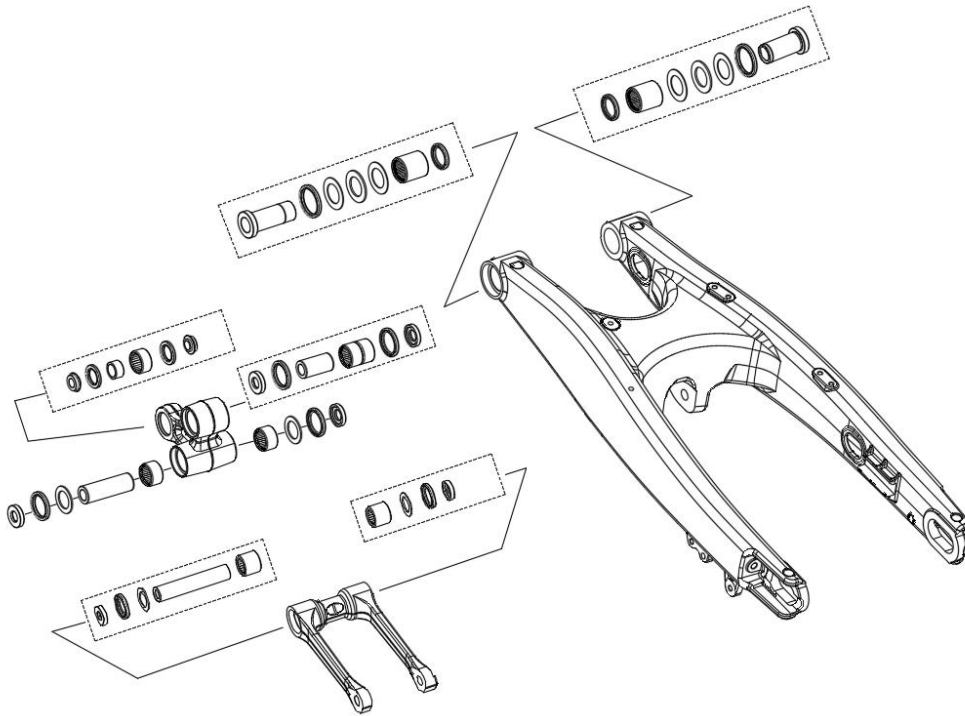

※ **Rear shock absorber assembly**

Discard the rear shock absorber

1. Before discarding the shock absorber, the gas pressure must be released. To release the gas pressure, drill a 2-3mm diameter bore in the flat part of the gas cylinder [1] as shown in the figure.



- Wear goggles to prevent eye injury caused by released gas or metal debris.

Removal rear shock absorber assembly

1. Stand the vehicle on a flat surface.



- Support the vehicle firmly so as not to turn over.

Note

- Support the vehicle with the maintenance bracket so that the rear wheel is lifted
- When removing the bolt, fix the swing arm so that it will not fall.

2. Disassemble:

Rear shock absorber

See "Rear wheel/suspension" on Page 253 for details.

Check the rear shock absorber assembly

3. Inspection:

- Rear shock absorber inner rod Bent/damage → Replace the rear shock absorber assembly.

- Rear shock absorber assembly (built-in airbag) Bent/damage → Replace the rear shock absorber assembly.

- Bushing

- Spring

Damage/wear → Replace the rear shock absorber assembly.

- Size of Bolts

Bent/damage/wear → replace.



- This rear shock absorber contains nitrogen compressed under high pressure. Before handling the rear shock absorber, please read and understand the following information. The manufacturer is not liable for any property or personal injury that may be caused by improper handling of the rear shock absorber.
- Do not modify or attempt to remove the rear shock absorber.
- Do not place the rear shock absorber around an open flame or any other high-temperature heat source, since the high temperature may cause excessive gas pressure and lead to an explosion.
- Do not use a rear shock absorber that is deformed or damaged. A damaged shock absorber will result in a decline in performance.

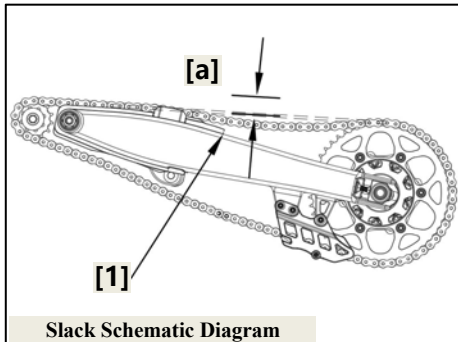

Slack Schematic Diagram

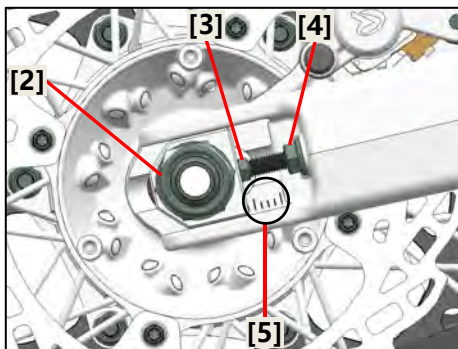

※ **Inspection and adjustment of slack of drive chain**

1. Place the vehicle on the workbench.



- Support the vehicle firmly so as not to turn over.

Notes

- An overly tight drive chain can overload the engine and other major components, and an overly loose drive chain can cause slippage and damage the rear flat swingarms or cause an accident. It is therefore necessary to ensure that the drive chain slack is within the specified limits.

2. Put the vehicle in neutral.
3. Rotate the rear wheel backward and keep the drive chain taut.

4. Inspection:

- Slack of transmission chain

Off-specification → Adjust.

Note

- Start from the position [1] indicated by the arrow, and measure the distance [a] between the centers.

Standard: 35-45 mm

Notes

- Improper slack in the drive chain can overload the engine and other critical components of the motorcycle, leading to chain slippage or breakage. If the drive chain slack exceeds the specified limit, it may damage the frame, swingarm, and other parts. To prevent this, maintain the drive chain slack within the specified limit.

4. Loosen:

- Rear wheel axle nut [2]

See "Rear Wheel, Suspension" on Page 139 for details.

5. Adjustment:

- Slack of transmission chain

- a. Loosen the two drive chain adjusting block locking nuts [3].
- b. Turn the two drive chain adjusting block bolts [4] until the specified range of drive chain slack is obtained.

Note

- To maintain correct wheel alignment, make sure to align the adjusting blocks on both sides with the scale marking line [5].
 - There shall be no clearance between the adjusting blocks and the head of the adjustment bolt.
- c. Tighten the rear axle nut to the specified torque.

Rear wheel axle nut

128 N·m (12.8 kgf·m, 94 lbf·ft)

- d. Tighten the adjusting block locking nuts to the specified torque.

Drive chain adjusting block locking nut

16 N·m (1.6 kgf·m, 12 lb·ft)

※ **Inspection, cleaning and lubrication of transmission chain**



- To ensure the service life and strength of the chain, please use the original manufacturer's specification for the drive chain.

Notes

- For optimal service life, it is highly recommended to clean and lubricate the transmission chain after every drive.

1. Disassembly

Remove the front sprocket decorative cover, the master link clip [1], the link plate [2], and the master link [3], then disconnect the drive chain. Check if the master link clip is in good condition. Replace if necessary.

2. Inspection:

If the measured value exceeds the maintenance limit, please replace the transmission chain.

3. Measurement:

Measure the distance [a] between 17 pins (16 pitches) from the center of one pin to the center of the next, while ensuring the chain remains tight and any bent joints are straightened.

Use limit: 257m

If the measured value exceeds the maintenance limit, please replace the drive chain.

4. Clean:

Clean the drive chain [1] with a non-flammable or high-flash-point solvent and dry it. Ensure the chain is completely dry before lubrication.

Check the drive chain for damage or wear.

Replace any damaged rollers, loosely assembled links, or an unusable drive chain.

5. Lubrication

Apply drive chain lubricant [2] to properly lubricate the drive chain [1].

Recommended lubricants:

Use chain lubricant or SAE #80-90 gear oil to wipe off any excess oil or lubricant.

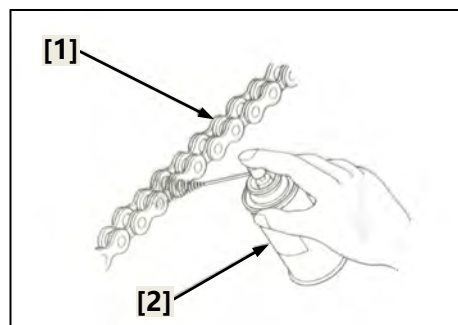
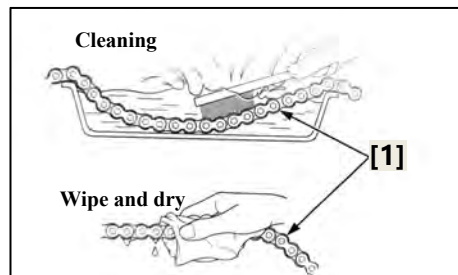
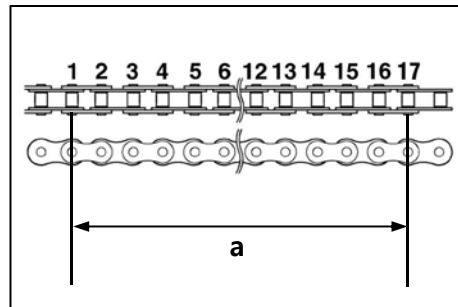
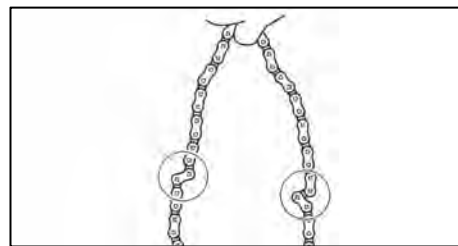
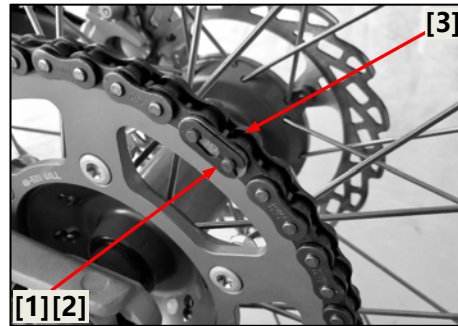

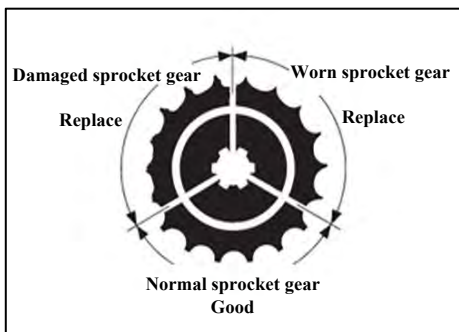
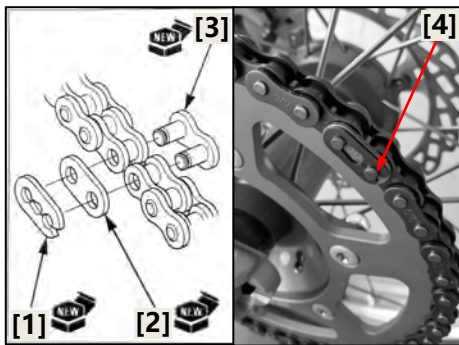
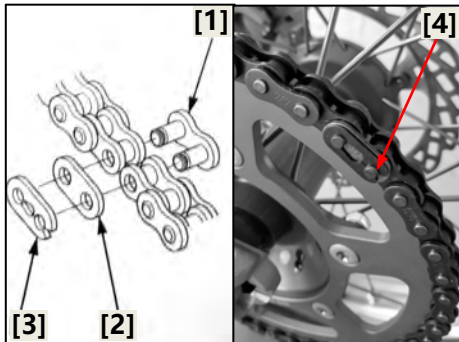

Notes

- Install the driving sprocket on the engine counter shaft and apply thread adhesive (Huitian 7272).

7. Installation

Install the drive chain on the sprockets.
Install the master link [1] and the link plate [2].
Install the master link clip [3] with its open end [4] always facing rearward when the drive chain is on the upper side of the swingarm.
Install the front sprocket decorative cover.
Adjust the looseness of drive chain.

※ **Replacement of drive chain**

Remove the drive sprocket cover and the master link clip [1].

Note: Be careful not to damage the master link clip.

Remove the link plate [2] and the master link [3] to disconnect the drive chain.

Remove the drive chain.

Standard chain: 114 links

Replacement chain: Choho 520ND-114L

Notes

- Never use new drive chains on worn sprockets. Both the chain and sprocket must be in good condition; otherwise, the newly replaced drive chain will wear out quickly.

When replacing the drive chain, inspect the sprocket as well.

Install the drive chain on the sprockets.

Install the new master link [3] and the link plate [2].

Install the new master link clip [1] with its open end [4] always facing rearward when the drive chain is on the upper side of the swingarm.

Install the front sprocket decorative cover.

Note

- After replacing the chain, adjust the drive chain slack to the specified range again.

※ **Drive/driven sprockets**

Remove the drive sprocket cover.

Check the drive sprocket gear teeth and driven sprocket gear teeth for wear or damage, replace them if necessary.

Consult your dealer to replace the drive sprocket and driven sprocket.

Never use new drive chains on worn sprockets. Both the drive chain and sprocket must be in good condition; otherwise, the newly replaced drive chain will wear out quickly.

Check the bolts and nuts on the drive sprocket and driven sprocket. If there is any looseness, tighten to the specified torque value.

Torque:

Drive sprocket bolt:

Bolts connecting driven sprocket to wheel hub:

38 N·m (3.8 kgf·m, 28 lbf·ft)

Hydraulic Brake

Section 1 Maintenance instructions	152
Section 2 Troubleshooting	152
Section 3 Position of components	153
Section 4 Inspection of brake fluid level	154
Section 5 Inspection and replacement of brake pads	155
Section 6 Inspection and replacement of brake discs	156
Section 7 Hydraulic brake system exhausting	157
Section 8 Front brake pump	158
Section 9 Rear brake pump	159
Section 10 Adjustment of rear brake pedal	160
Section 11 Rear brake pedal assembly	160
Section 12 Front brake caliper	161
Section 13 Rear brake caliper	162

Maintenance Instructions

Overview:

- This section describes the maintenance of conventional brake components of the brake system.
- This section describes how to perform the brake fluid replacement procedure and the exhaust process.
- Contaminated brake discs or brake pads will reduce braking efficiency.
- Discard contaminated brake pads and clean contaminated brake discs with high-quality brake degreaser.
- In maintenance of the system, be sure to use fresh DOT 4 brake fluid in a sealed container and do not mix different types of fluids which may not be compatible.
- Prevent any contaminants (dirt, water, etc.) from entering the unclosed reservoir.
- Once the hydraulic system is turned on, or if the braking force is insufficient, the brake system must be emptied, and the brake operation must be checked.
- Spilled brake fluid will seriously damage the instrument surface, painted surface and rubber parts; be careful when removing the reservoir lid, first make sure that the front reservoir is horizontal.

Troubleshooting

Insufficient braking force of brake handlebar/pedal

- Air in hydraulic system
- Leakage in hydraulic system
- Contaminated brake pads/discs
- Wear of brake caliper piston seal
- Wear of main piston cup
- Contaminated brake pads/discs
- Contaminated brake caliper
- Contaminated brake pump
- Abnormal sliding of brake caliper shaft
- Low brake fluid level
- Oil passage blockage
- Distortion/deformation of brake disc
- Brake caliper piston stuck/worn
- Main piston stuck/worn
- Brake handlebar/pedal bend

Brake handlebar/pedal requires force

- Blocked/restricted oil passage
- Brake caliper piston stuck/worn
- Abnormal sliding of brake caliper
- Wear of brake caliper piston seal
- Main piston stuck/worn
- Brake handlebar/pedal bend
- Brake resistance
- Contaminated brake pads/discs
- Misaligned wheels
- Severe wear of brake pads/discs
- Distortion/deformation of brake disc
- Abnormal sliding of brake caliper
- Blocked/restricted oil passage
- Caliper piston stuck

Position of Components

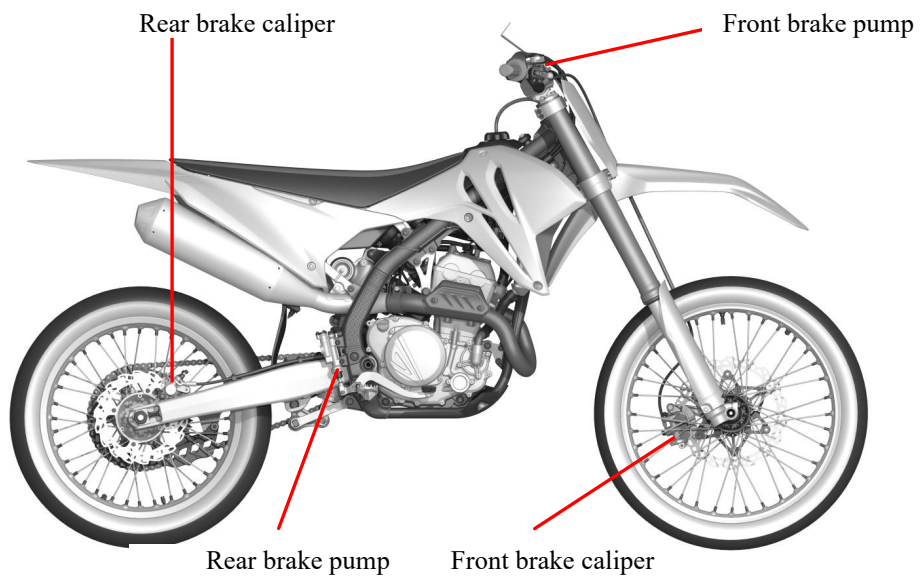

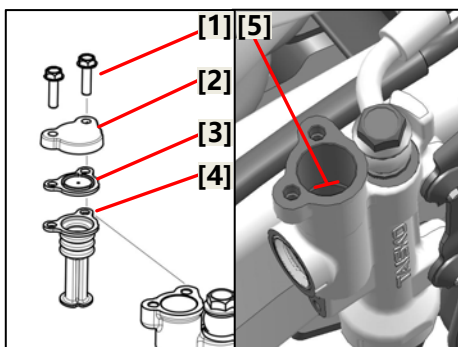
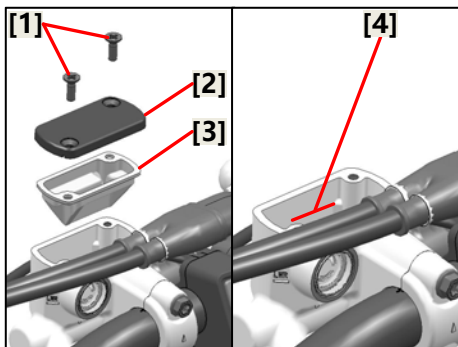
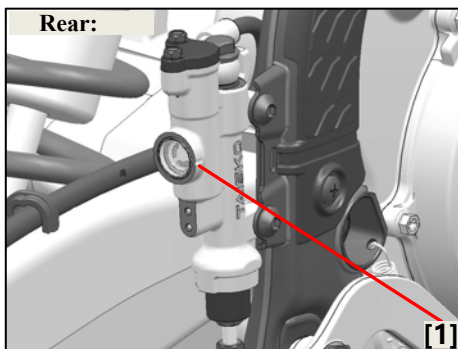
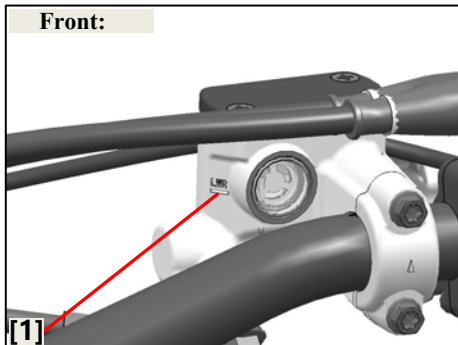

※ **Inspection of brake fluid level**



- Spilled brake fluid can damage paint, plastic or rubber parts.

Notes

- Ensure not to mix incompatible types of brake fluids together.
- During the process of filling the reservoir, take care to prevent any foreign matter from entering.

※ **Level inspection**

Check the brake fluid level in both the front and rear brake pump liquid reservoirs.

If the level is close to the lower level line [1], check the brake pads for wear. If the brake pads are not worn and the level is low, check the entire system for leaks and proceed to fill the reservoir with brake fluid.

※ **Brake fluid addition**

- **Front brake pump;**

Remove the front brake pump reservoir cover screw [1], reservoir cover [2], and lining [3].

Fill the reservoir with the recommended brake fluid to the upper level line [4]. Use the recommended brake fluid: DOT4 brake fluid

Install the lining and reservoir cover.

Install and tighten the front brake reservoir cap screws to the specified torque.

Torque:

1.0 N·m (0.1 kgf·m, 0.7 lbf·ft)

Check the front brake hydraulic system for leaks.

- **Rear brake pump;**

Remove the rear brake pump reservoir cover screw [1], reservoir cover [2], gasket [3], and lining [4].

Fill the reservoir with the recommended brake fluid to the upper level line [5]. Recommended brake fluid: DOT4 brake fluid

Install the lining [4], gasket [3], and cover [2].

Install and tighten the rear brake pump reservoir cover bolt [1] to the specified torque.

Torque:

2.0 N·m (0.2 kgf·m, 1.5 lbf·ft)

Check the front brake hydraulic system for leaks.

※ **Inspection and replacement of brake pads**

- Front brake pad:

By inspecting the front wheel brake pads, the wear condition can be determined. If the wear thickness of any brake pad reaches 1.0mm, the entire set of brake pads must be replaced.

- Rear brake pad:

Check the brake pad from the rear side of the brake caliper to determine the wear of the brake pad. If the wear thickness of any brake pad reaches 1.0mm, the entire set of brake pads must be replaced.

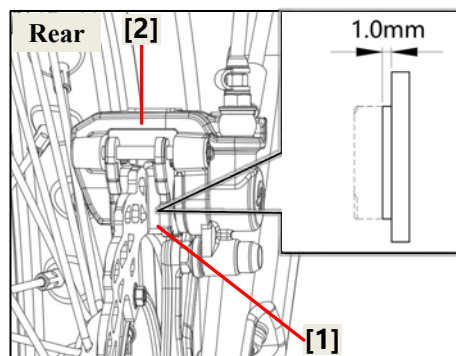
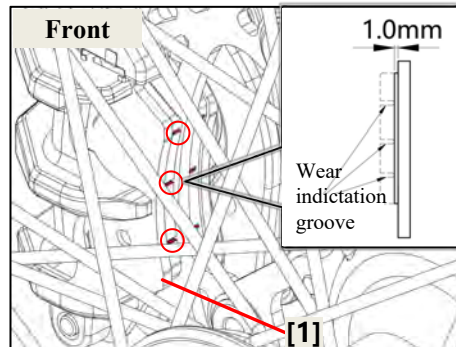

Notes

- When replacing the brake pads, it is not needed to disassemble the brake hose.

Replace front/rear brake pads

The following steps apply to the front/rear brake pad piece.

1. Disassembly: **Front brake pad**

- Bolt [1];
- Caliper [2];
- Brake pad guide pin bolt [3];
- Brake pad and spring [4].

2. Disassembly: **Rear brake pad**

- Brake pad guide pin bolt [5];
- Brake pad, heat shield, spring [6].

Note

- When replacing brake pads, please replace them as a complete set.

The steps are as follows:

- Connect the transparent hose to the bleed screw and place the other end into an empty container.
- Loosen the bleed screw and use an appropriate tool to push the caliper piston into the brake caliper.
- Tighten the bleed screw.
- Install the brake pad and brake pad spring.

3. Install:

- Brake pad guide pin bolt;
- Brake caliper. (Front brake caliper)

4. Inspection:

- Brake fluid level

Below minimum level → Add brake fluid.

See "Brake fluid addition" on page 154 for details.

- Hand brake lever operation

Soft → Bleed the brake system

See "Hydraulic brake system bleeding" on Page 157 for details.

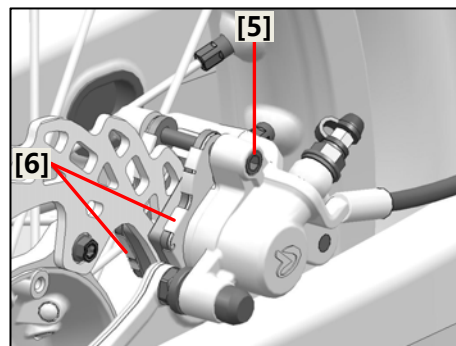
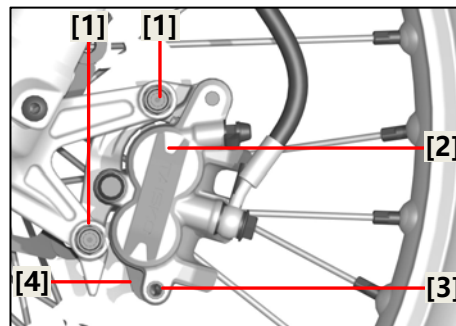

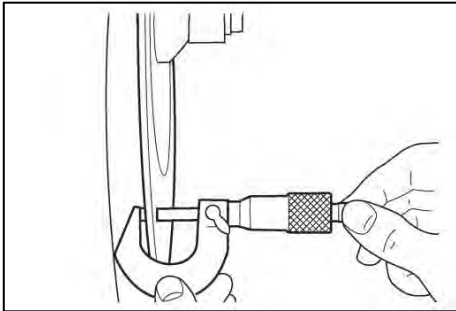

※ Inspection and replacement of brake discs

Inspection

- Visually check the brake disc for damage or cracks.

Measure the wear limit of brake disc:

Front brake disc: **2.5 mm**

Rear brake disc: **2.5 mm**

Damage/deformation/off-specification → Replace

Replace brake discs

The following steps apply to the front/rear brake discs.

1. Disassembly

A: Before

- Front wheel assembly;

See "Front Wheels, Suspension, Steering" on page 127 for details.

- Remove 6 mounting bolts of the brake disc;
- Remove the disc brake disc [2].

2. Disassembly

B: Rear

- Rear wheel assembly;

See "Rear Wheel, Suspension" on Page 139 for details.

- Remove 4 mounting bolts of the brake disc;
- Remove the disc brake disc [2].

Torque:

Front brake disc mounting bolts

12 N·m (1.2 kgf·m, 9.0 lbf·ft)

Rear brake disc mounting bolt

12 N·m (1.2 kgf·m, 9.0 lbf·ft)

Note

- Tighten the bolts in the order indicated by the arrow numbers.

Notes

- Apply thread adhesive to the threaded parts during installation.
(Huitian 7272)

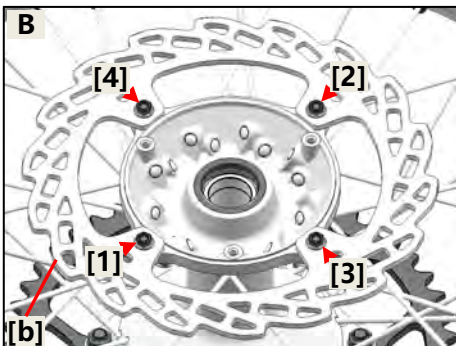
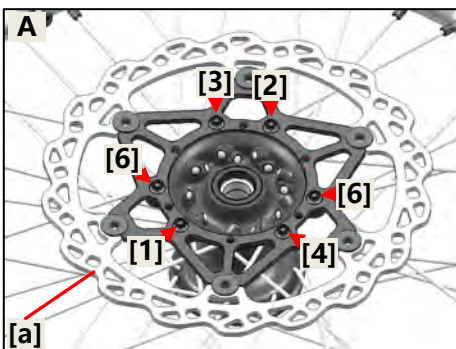

※ Hydraulic brake system bleeding



- After removing the brake-related parts, ensure to bleed the brake system.

Note:

- Exhaust the brake system in the following sequence.
- Step 1: Front brake caliper.
- Step 2: Rear brake caliper.



State of releasing brake system air:

- Brake pump is disassembled.
- Brake hose is loose, removed or replaced.
- Brake fluid level is below the minimum mark.
- There is a malfunction in the brake operation.

Note

- Take care to avoid spilling brake fluid or allowing the brake master cylinder reservoir or brake caliper reservoir to overflow.
- When releasing the air from the hydraulic brake system, ensure that the brake fluid level is sufficient before running the brake. Skipping this step will allow air to enter the hydraulic brake system, resulting in a significant increase in the time required for the bleeding procedure.
- If releasing is difficult, it may be necessary to allow the brake fluid to settle for several hours. Once the small bubbles in the hose have disappeared, repeat the release procedure.

1. Exhaust:

- Fill the brake fluid reservoir to the appropriate level using the specified brake fluid.
- Install gasket (brake master cylinder reservoir or brake fluid reservoir).
- Connect the clear plastic hose [1] tightly to the bleed bolt [2].

A. Front

B. After

- Place the other end of the hose in the container.
- Run the brake slowly/several times.
- Pull up the brake handle completely, or press the brake pedal all the way down until it is fully engaged.
- Loosen the bleed screw.

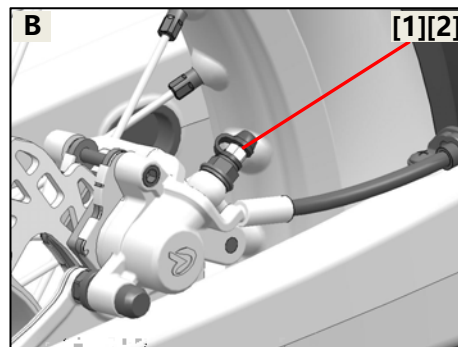
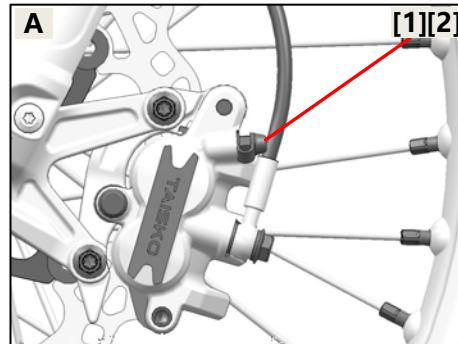

Note

Loosen the bleed screw to release air and ensure that the brake handle makes full contact with the throttle grip or brake pedal.

h. Tighten the bleed screw and release the brake handle or brake pedal.

i. Repeat steps (e) to (h) no bubbles are visible in the brake fluid within the plastic hose.

j. After operating the brake, repeat steps (e) to (i) and fill the brake master cylinder reservoir or brake fluid reservoir to the appropriate level using the specified brake fluid.

k. Tighten the bleed screw to the specified torque.

Brake caliper bleed screw [1]

9.0 N·m (0.9 kgf·m, 6.6 lb·ft)

m. Fill the brake master cylinder or brake fluid reservoir to the appropriate level using the specified brake fluid.

See "Add brake fluid" on page 154 for details.



- After air is completely removed from the hydraulic brake system, check the operation of the brakes.

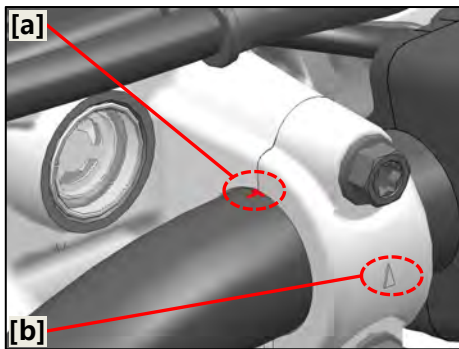
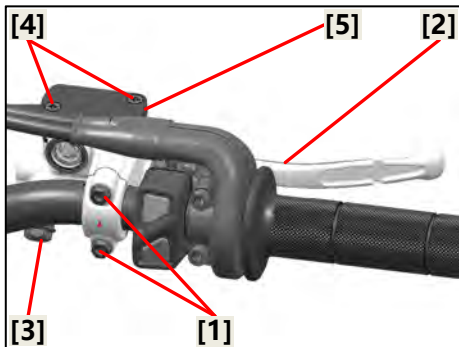

- Only use the specified brake fluid. Other brake fluids may cause aging of the rubber oil seal, resulting in leakage and poor braking performance.
- Please add the same kind of brake fluid as used in the system. Mixed brake fluid may cause adverse chemical reactions, resulting in degradation of braking performance.
- Be careful not to allow water to enter the brake oil cup during filling. The internal water will significantly reduce the boiling point of the brake fluid and cause air resistance.

※ Front brake pump

Note

- Before removal of the front brake pump, bleed the brake fluid of the entire brake system.

1. Disassemble:

- Brake pump mounting screw [1];
- Front brake pump [2];
- Oil passing bolt and shim [3];
- Reservoir cover screw [4];
- Reservoir cover and lining [5].

2. Inspection:

Front master cylinder

- Brake master cylinder
Damage/scratch /wear → Replace.
- Brake fluid passage
(Brake master cylinder body)
Blocked → Blow through with compressed air.

- Brake master cylinder assembly

Damage/scratch /wear → Replace.

- Brake master cylinder reservoir
- Master cylinder reservoir cover/lining

Crack/damage → Replace.

- Brake hose

Crack/damage /wear → Replace.

3. Installation:

The installation sequence is reversed from the removal sequence.

Notes

- Brake fluid may damage the painted surface and plastic parts. Be sure to clean up any spill of brake fluid immediately

Note

- Replace the new (oil passing bolt) sealing washer.
- Align the joint surface of the front brake pump fixing socket with the marking point [a] on the right side of the steering handlebar for installation.
- Install the front brake pump fixing socket with arrow [b] facing upwards.

Torque:

Front brake pump

8.0 N·m (0.8 kgf·m, 6.0 lbf.ft)

Brake oil pipe locking bolt

32 N·m (3.2 kgf·m, 24 lbf.ft)

※ **Rear brake pump**

Note

- Before removal of the rear brake pump, bleed the brake fluid of the entire brake system.

1. Disassemble:

- Oilpassing bolt and shim [1];
- Pin [2];
- Bolt [3];
- Rear brake pump [4].

2. Check:

Front brake pump

- Brake master cylinder

Damage/scratch /wear → Replace.

- Brake fluid passage

(Brake master cylinder body)

Blocked → Blow through with compressed air.

- Brake master cylinder assembly

Damage/scratch /wear → Replace.

- Brake master cylinder reservoir

- Brake master cylinder reservoir cover/gasket/lining

- Rear brake push rod seal rubber grommet

Crack/damage → Replace.

- Brake hose

Crack/damage /wear → Replace.

3. Installation:

The installation sequence is reversed from the removal sequence.

Notes

- Brake fluid may damage the painted surface and plastic parts. Be sure to clean up any spill of brake fluid immediately

Note

- When installing the connection between the rear brake pump and the frame, apply thread adhesive (Huitian 7272) to the threaded parts.
- When tightening the brake hose locking bolt, make sure that the oil pipe joint is against the limit protrusion.
- Replace the new (oil passing bolt) sealing washer.

Torque:

Rear brake pump and frame

12 N·m (1.2 kgf·m, 9.0 lbf·ft)

Brake hose bolt

32 N.m (3.2 kgf·m, 24 lbf·ft)

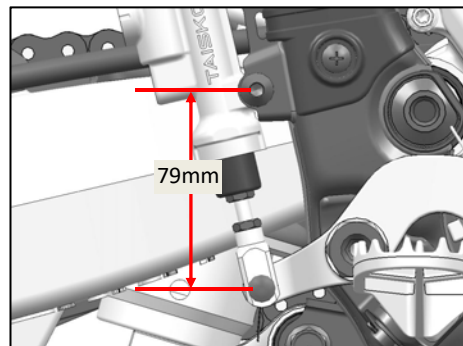
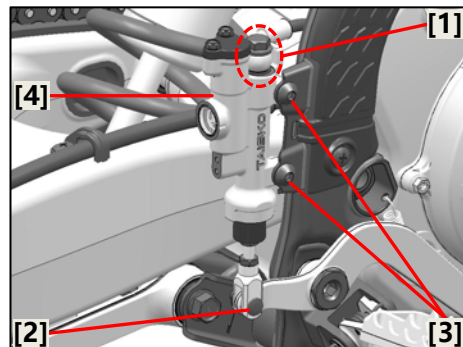

- Only use the specified brake fluid. Other brake fluids may cause aging of the rubber oil seal, resulting in leakage and poor braking performance.
- Please add the same kind of brake fluid as used in the system. Mixed brake fluid may cause adverse chemical reactions, resulting in degradation of braking performance.
- Be careful not to allow water to enter the brake oil cup during filling. The internal water will significantly reduce the boiling point of the brake fluid and cause air resistance.

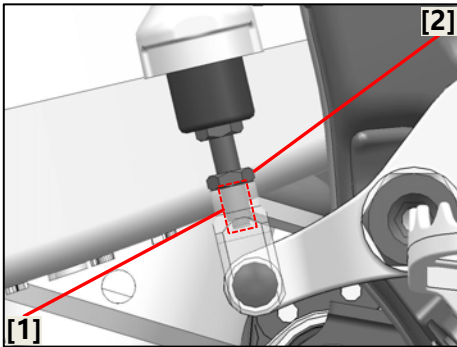

※ **Adjustment of brake pedal**

After removing the push rod, adjust its length so that the distance from the center of the lower mounting bolt hole of the brake pump to the center of the connecting pin hole is the standard length of **79mm**. If the length is adjusted to a longer position, make sure that the lower end of the push rod thread [1] is 5 mm in the connector, and tighten the connecting nut [2] to the specified torque after adjustment.

Rear brake pump push rod adjustment tightening nut:

6.0 N·m (0.6 kgf·m, 4.4 lbf·ft)

※ **Rear brake pedal assembly**

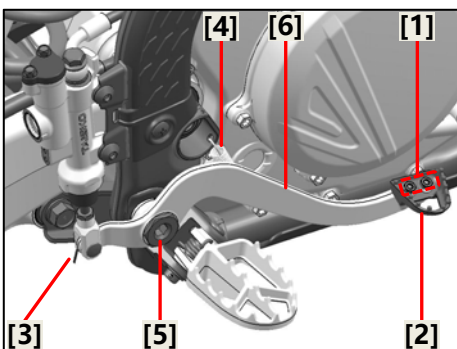

1. Disassembly

- Bolt [1];
- Rear brake pedal [2];
- Cotter pin, flat gasket, and pin [3];
- Rebound tension spring [4];
- Rocker arm mounting bolt [5];
- Rear brake rocker arm [6].

2. Inspection

- Rear brake rocker arm pivot oil seal [a]
- Damage → Replace.

3. Installation

The installation sequence is reversed from the removal sequence.

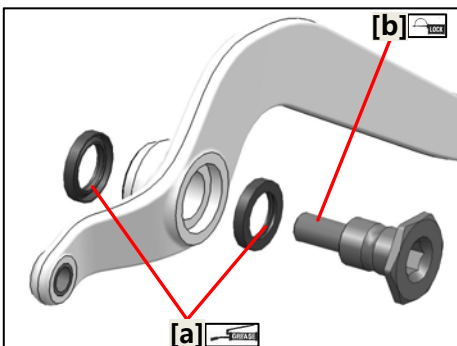

Notes

- During installation, apply grease to the groove between the main and auxiliary lips of the brake arm pivot oil seal [a].
- Lubricate with high-temperature extreme pressure composite lithium grease (UNIVERSAL SU-T330Y or equivalent).
- When installing the rear brake pedal, apply thread adhesive (Huitian) 7262.
- When installing the rear brake rocker arm bolt [b], apply thread adhesive (Huitian) 7272 on the thread.

Torque:

Rear brake rocker arm mounting bolt

22 N·m (2.2 kgf·m, 16 lbf·ft)

Rear brake pedal mounting bolt

8.0 N·m (0.8 kgf·m, 6.0 lbf·ft)

※ **Front brake caliper**

Notes

- Brake fluid may damage the painted surface and plastic parts. Be sure to clean up any spill of brake fluid immediately

1. Disassembly

- Oil passing bolt and shim [1];
- Brake hose [2]
- Bolt [3];
- Front brake caliper and caliper bracket [4];
- Brake pad guide pin bolt [5];
- Front brake pad [6].

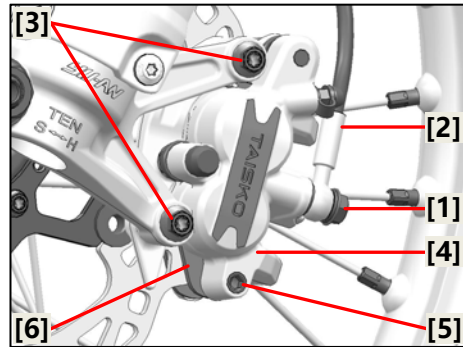

2. Inspection:

Inspection of front brake caliper

- Brake wheel cylinder
Damage/scratch /wear → Replace.
- Brake fluid passage
(Brake wheel cylinder body)
Blocked → Blow through with compressed air.
- Brake wheel cylinder assembly
Damage/scratch /wear → Replace.
- Front brake caliper upper and lower sliding shaft rubber grommet [a]
Crack/damage → Replace.
- Brake hose
Crack/damage /wear → Replace.

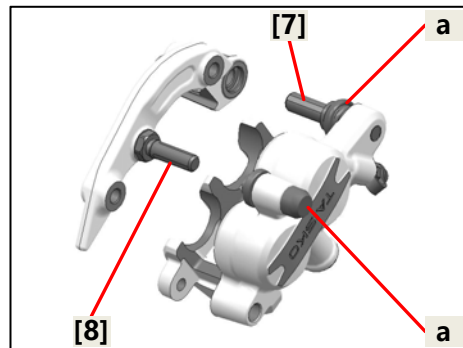

3. Installation

The installation sequence is reversed from the removal sequence.

Note

- During installation, apply compound lithium grease to the sliding areas [7], [8] of the upper and lower sliding shaft rods (Universal SU-T330Y).
- During installation, apply thread fastening (Huitian 7272) to the threads of both the sliding shaft bolt and the brake pad guide pins.
- When tightening the brake hose locking bolt, always ensure the hose connector rests against the limit protrusion on the brake caliper body.
- Replace with the new gasket (oil passing bolt).

Torque:

Front brake caliper mounting bolt

32 N·m (3.2 kgf·m, 24 lbf·ft)

Brake hose bolt

32 N·m (3.2 kgf·m, 24 lbf·ft)

Brake pad guide pin bolt

15 N·m (1.5 kgf·m, 11 lbf·ft)

Upper and lower sliding shaft bolts

20 N·m (2.0 kgf·m, 15 lbf·ft)

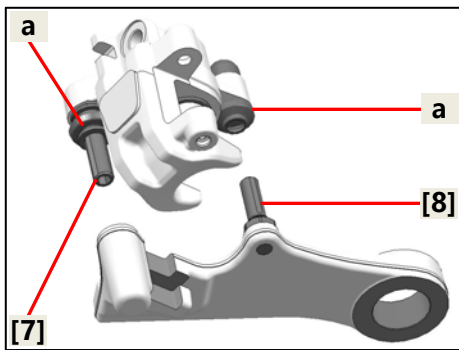
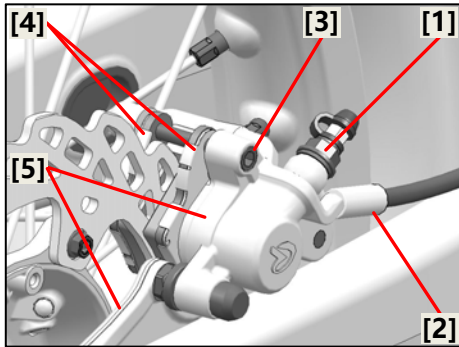

※ Rear brake caliper

Notes

- Brake fluid may damage the painted surface and plastic parts. Be sure to clean up any spill of brake fluid immediately

1. Disassembly

- Oil passing bolt and shim [1];
- Brake hose [2]
- Brake pad guide pin bolt [3];
- Rear brake pad, heat shield and spring [4];
- Rear wheel assembly;

See "Rear Wheel, Suspension" on Page 139 for details.

- Rear brake caliper and caliper bracket [5].

2. Inspection:

Inspection of rear brake caliper

- Brake wheel cylinder
Damage/scratch /wear → Replace.
- Brake fluid passage
(Brake wheel cylinder body)
Blocked → Blow through with compressed air.
- Brake wheel cylinder assembly
Damage/scratch /wear → Replace.
- Rear brake caliper upper and lower sliding shaft rubber grommet [a]
Crack/damage → Replace.
- Brake hose
Crack/damage /wear → Replace.

3. Installation

The installation sequence is reversed from the removal sequence.

Note

- During installation, apply compound lithium grease to the sliding areas [7], [8] of the upper and lower sliding shaft rods (Universal SU-T330Y).
- During installation, apply thread fastening (Huitian 7272) to the threads of both the sliding shaft bolt and the brake pad guide pins.
- Replace with the new gasket (oil passing bolt).
- When tightening the brake hose locking bolt, always ensure the hose connector rests against the limit protrusion on the brake caliper body.

Torque:

Brake hose bolt

32 N·m (3.2 kgf·m, 24 lbf·ft)

Brake pad guide pin bolt

15 N·m (1.5 kgf·m, 11 lbf·ft)

Upper and lower sliding shaft bolts

20 N·m (2.0 kgf·m, 15 lbf·ft)

Electrical Components

Section 1 Maintenance instructions	164
Section 2 Position of components	165
Section 3 Electronic control unit (ECU)	166
Section 4 Throttle body assembly	168
Section 5 Three-in-one sensor	169
Section 6 Fuel injector	170
Section 7 Ignition coil	171
Section 8 Fuel pump assembly	172
Section 9 Engine water temperature sensor	173
Section 10 Magneto	174
Section 11 Rectifier regulator	175
Section 12 Trigger	176
Section 13 Starting relay	177
Section 14 Shift sensor	178
Section 15 Gear sensor	178
Section 16 Main relay inspection	179
Section 17 Inspection of vehicle ground wire harness	179
Section 18 Battery	180
Section 19 Handlebar switch-left	181
Section 20 Handle switch-right	182

Maintenance Instructions

Precautions:

- During maintenance, it is forbidden to disassemble the parts of EFI system.
- During maintenance, extreme care shall be exercised on work with electronic components (ECUs, sensors, etc.) to prevent missing. Furthermore, do not touch the pins of electrical components at will to avoid damage caused by electrostatic breakdown.
- Do not remove the connectors of any components of the EFI system from their installation positions without authorization, to avoid accidental damage or foreign matters such as water and oil entering the connectors, which may affect the normal operation of the EFI system.
- When disconnecting and connecting the connector, be sure to put the ignition switch in the off position, otherwise the electrical components will be damaged.

Position of Components

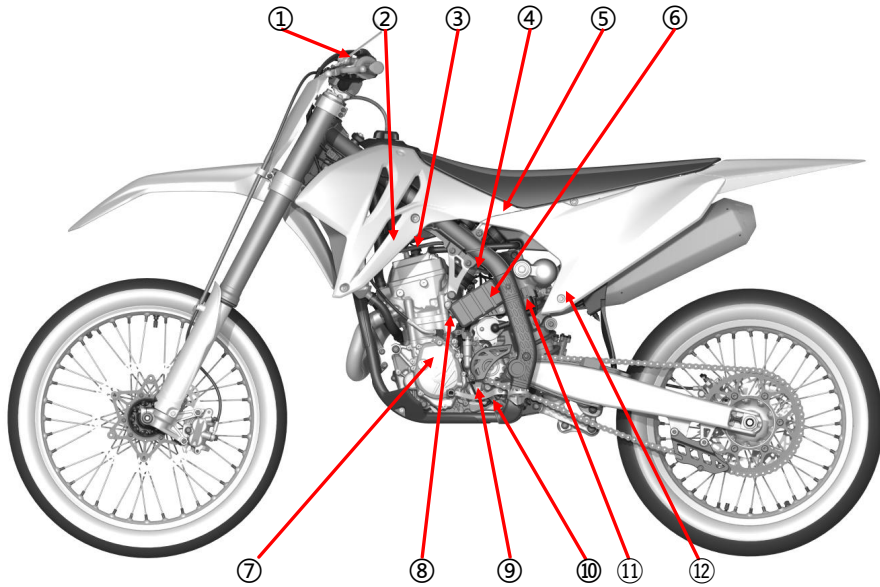

S/N	Component Name
1	Handlebar assembly switch
2	Fuel pump assembly
3	Ignition coil
4	Throttle/fuel injector/three-in-one sensor
5	ECU control unit
6	Battery
7	Magneto/trigger
8	Water temperature sensor
9	Gear sensor
10	Quick-shifting sensor
11	Starting relay
12	Rectifier regulator

Drawing of ECU

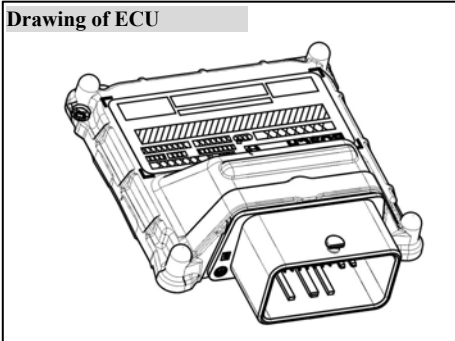

Drawing of ECU connector

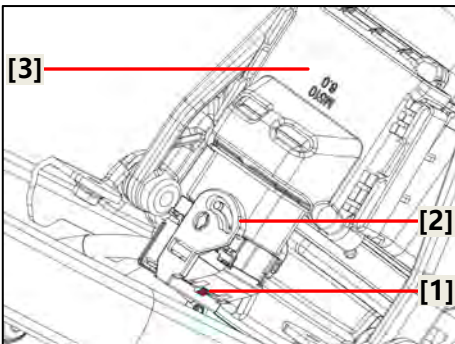
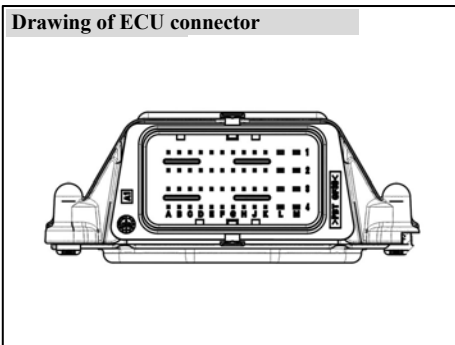

※ **Electronic control unit (ECU)**

The electronic control unit is the brain of the whole EFI system and electrical appliances. It analyzes and processes all kinds of information provided by sensors, and sends the conclusion to the actuator in the form of command, so that the engine can run in the optimum state.



- Do not use tools when dismantling the ECU to avoid damaging the connector buckle.
- It is not allowed to increase the load on the housing or cover plate; handle with care and prevent falling to the ground.
- When disconnecting and connecting the ECU connector assembly, be sure to set the ignition switch to OFF position, or the electrical components will be damaged.

Note

- While pressing position [1], turn position [2] clockwise, then the connection between the ECU and the cable can be disconnected.
- Remove the ECU control unit and rubber grommet from the clip.

Quantity value					
		Minimum	Standard	Maximum	Unit
Vehicle voltage	Normal operation	9.0	12.8	15.0	V
Limit and time to withstand vehicle over-voltage	15V	Some functions are maintained and fault diagnosis can be performed.		120	min
Operating temperature		-30		+70	°C
Storage temperature		-30		+85	°C

※ Schematic Diagram of Outgoing Direction of ECU Connector

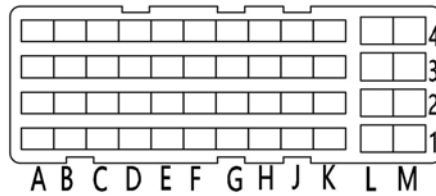

ECU PIN Function Definion: Revised 2.26

Pin Number	Pin Number	Wire harness color	Pin Number	Pin Number	Wire harness color
1(A1)	-	-	25(A3)	Neutral gear signal input	W/Y
2(B1)	-	-	26(B3)	-	-
3(C1)	CAN communication line - high	G/L	27(C3)	-	-
4(D1)	CAN communication line - low	R/Y	28(D3)	Launch switch signal input	Y/G
5(E1)			29(E3)	Diagnostic K-line	W/G
6(F1)	Water temperature sensor signal	Gr/G	30(F3)	Continuous power supply (12V)	R/W
7(G1)	Throttle position	P/W	31(G3)	Ignition signal	B/W
8(H1)	IAT sensor	P/B	32(H3)	-	-
9(J1)	Sensor GND	G/B	33(J3)	5V power supply	P
10(K1)	Intake pressure sensor	P/G	34(K3)	-	-
11(L1)	-	-	35(L3)	-	-
12(M1)	-	-	36(M3)	ECU ground	G
13(A2)	-	-	37(A4)	Fuel injector	O/B
14(B2)	-	-	38(B4)	-	-
15(C2)	-	-	39(C4)	Fuel pump relay	Br/B
16(D2)	-	-	40(D4)	-	-
17(E2)	-	-	41(E4)	-	-
18(F2)	-	-	42(F4)	Pulse signal A	L/W
19(G2)	Quick-shifting sensor	L/B	43(G4)	Pulse signal B	G/W
20(H2)	-	-	44(H4)	-	-
21(J2)	-	-	45(J4)	-	-
22(K2)	-	-	46(K4)	Mode switch signal input	Gr/L
23(L2)	-	-	47(L4)	Main relay input: 12V	B/W
24(M2)	Ignition coil	B/Y	48(M4)	-	-

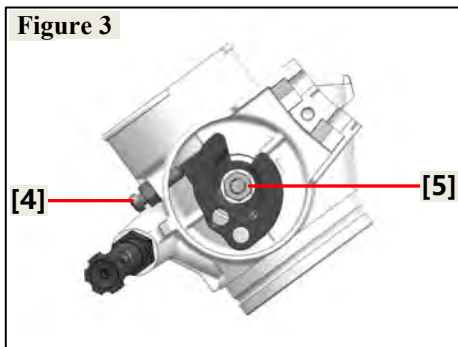
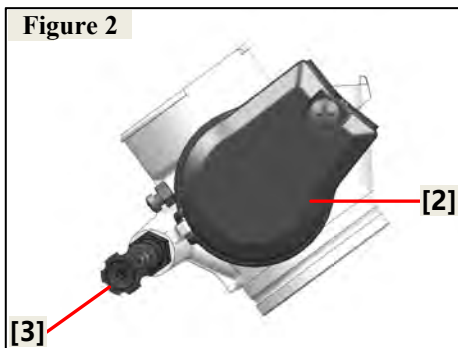
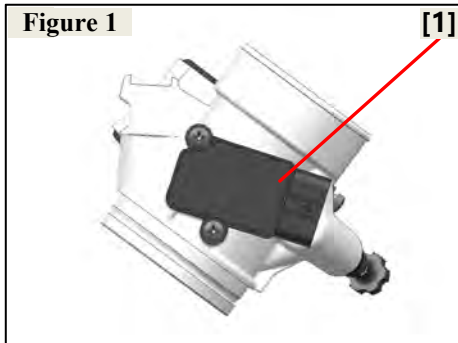

※ **Throttle body assembly**

Connect the air filter and engine, control the angle of the throttle plate through the accelerator cable, and the throttle position sensor will send the angle signal to ECU.

As shown in Figure 1 and 2: Sensor and component positions:

1. Three-in-one sensor [1];
2. Eccentric wheel [2];
3. Choke knob [3]

Precautions in sensor installation:

1. The terminals shall not be stained with water, oil and other liquids;
2. Do not contact harmful gases (Cl, SO₃, etc.);
3. Do not exert external force to cause deformation or damage of parts;
4. Direct contact with terminals is not allowed (to prevent static electricity);
5. It is necessary to block the pressure channel when cleaning the throttle.

As shown in Figure 3, the idle limit screw [3] and eccentric wheel nut [4] must not be adjusted.



- The engine idle speed is completely adjusted by EFI system, and manual adjustment of the idle limit bolts is not allowed.
- It is not allowed to increase the load on the shell or cover plate.
- 1 When dismantling, handle with care to avoid falling.

As shown in the Figure 1:

Three-in-one sensor mounting screws
Torque: 2.0 N·m (0.2 kgf·m, 1.5 lbf·ft)

As shown in Figure 2:

Eccentric wheel mounting screw
Torque: 2.0 N·m (0.2 kgf·m, 1.5 lbf·ft)

Throttle valve body inspection:

1. The throttle plate moves flexibly and is not stuck;
2. There is no foreign matter in throttle body and oil/gas passages (foreign particle size < 0.34 mm);
3. There is no missing assembly and incorrect assembly of parts or missing parts, and the internal parts are installed firmly without falling off;
4. The throttle screw is tightened reliably without loosening.

※ **Three-in-one sensor**

IAT sensor

It is installed on the right side of the air filter box bottom and used to detect the real-time temperature of air before it is drawn into the engine cylinder and feeds back the signal to the ECU to adjust the fuel injection quantity of the engine, thereby enhancing engine combustion efficiency.

Intake pressure sensor

Monitor the intake pipe pressure and provide the engine load information for ECU.

Throttle position sensor

The throttle position sensor is generally equipped with a throttle coupling shaft. By turning the accelerator handle, the driver drives the throttle flap to rotate, and then transmits the rotation information to the throttle position sensor through the throttle shaft and the throttle coupling shaft, so as to monitor the opening of the throttle and transmit the position signal to the ECU, measure the intake air volume, control the fuel injection volume of the engine, and realize the real-time control of the engine speed.

Function definitions of pins:

1. Intake air temperature (TS) to ECU (H1) P/B;
2. Throttle position (Vtps) to ECU (G1) P/W;
3. Ground (GND) to ECU (J1) G/B.
4. Power supply 5V+ (Vin) to ECU (J3) P;
5. Intake pressure (Vp) to ECU (K1) P/G;

Install:

It shall be installed within a permissible range, making sure that no condensate water will be generated in the sensor, because condensate water will damage the sensing elements inside the sensor.

The figure on the right is a wiring diagram for connection between different sensors and ECU.

Sensor voltage/resistance parameters

- Throttle position sensor voltage: 0.65V at 11°, 3.95V at 90°.
- Intake pressure voltage: 1.412V at 35 kPa, 3.84V at 95 kPa.
- IAT sensor resistance: 2.056 kΩ at 25°C.

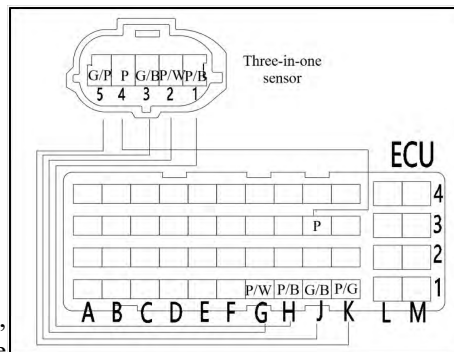
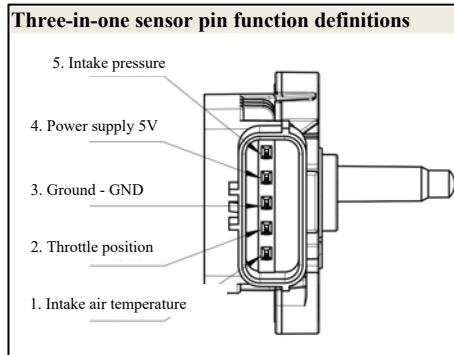
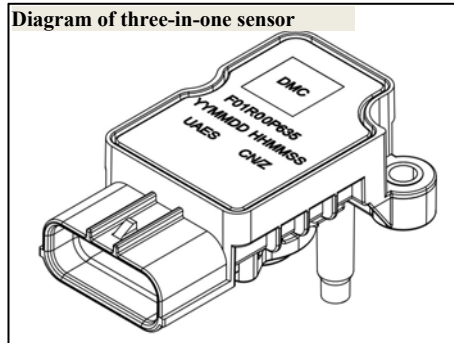

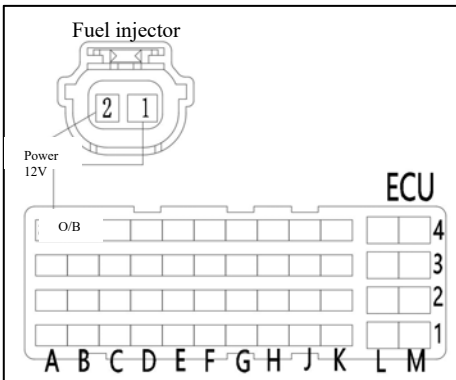
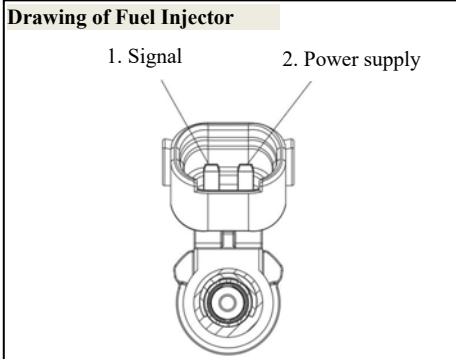

Inspection of fuel injector

1. Inspection:
 - Fuel injector

Stuck → replace and check the fuel pump/fuel system.
 Accumulation → Replace.
 Damage → Replace.
2. Inspection:
 - Fuel injector resistance

Injector resistance: $12 \Omega \pm 5\%$

※ Fuel injector

One end of the injector is installed on the injector seat, and the other end is connected to the oil pipe through the injector cap. It injects fuel within the specified time according to the command of ECU, thus providing fuel to the engine and atomizing it. The fuel injector adopts 8-hole dual-beam injection, and cannot rotate after the circlip is fixed.

Function definitions of pins:

Fuel injector

1. Connect to 12V+ power supply (R/W)
2. Signal connected to (A4) pin of ECU37 (O/B)

The figure on the left is a wiring diagram for connection between injector and ECU.

Note:

1. In order to avoid contamination to the injecting area, the fuel inlet end of the injector shall always be above the fuel outlet end (at the injector mounting position on the entire vehicle);
2. To achieve the best assembly of fuel injector, it is necessary to lubricate the upper and lower O-ring with clean silicone-free engine oil; Lubricating oil shall not contaminate the inside and orifice of the injector;
3. The O-ring must be replaced when removing and reassembling the injector, and the sealing surface must not be damaged during such operation.

Installation of fuel injector:

The fuel injector shall be installed by hand and the use of tools such as hammers to strike is prohibited. The O-ring must be replaced when removing and installing the fuel injector; Before disassembling the fuel injector, relieve pressure if necessary; after installation of the injector, check the sealing performance to ensure no leakage.

※ **Ignition coil**

The ignition coil converts low voltage electricity of the primary winding into high voltage electricity of the secondary winding, and generates sparks through the discharge of spark plugs to ignite the fuel mixture in the cylinder.

Function definitions of pins:

Ignition coil

1. Ignition signal to ECU (M2) B/Y;
2. Connect to 12V+ power supply (R/W);

As shown in the right figure: Wiring diagram for ignition coil and ECU.

1. Check:

- Primary high voltage coil resistance
Non-conformance → Replace.

a. Remove the ignition coil connector from the terminal.

b. As shown in the right figure: Diagram for connecting the multimeter to the high-voltage coil.

- Positive electrode test probe → [1]
- Negative electrode test probe → [2]

c. Measure the resistance of the primary ignition coil winding.

Ignition coil parameters

1. Static parameters

Primary resistance: 1.98–2.42 Ω

Secondary resistance: 9.45–11.55kΩ

Primary inductance: 4.25–5.75 mH

Secondary inductance: 9.775–13.225mH

2. Dynamic parameters:

Rated voltage: 13.5–14.5V

Primary current: 4.1–5.9A

Ignition pulse width: 7.5 - 0.5 msec

Secondary high voltage: MIN 25kV at 50pF

Load

Ignition energy: no less than 25 mJ

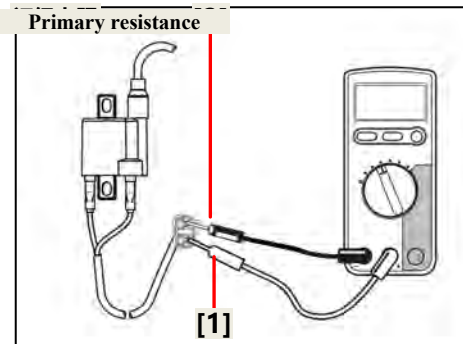
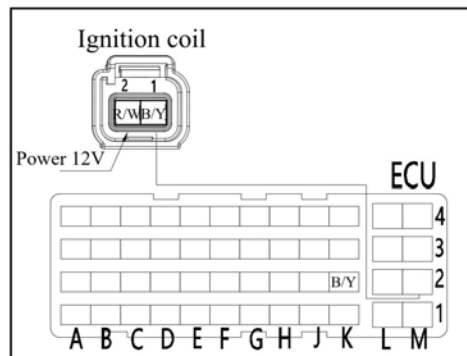
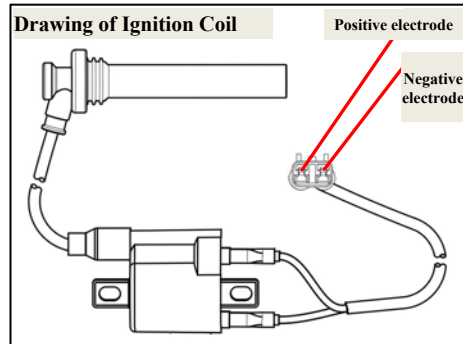

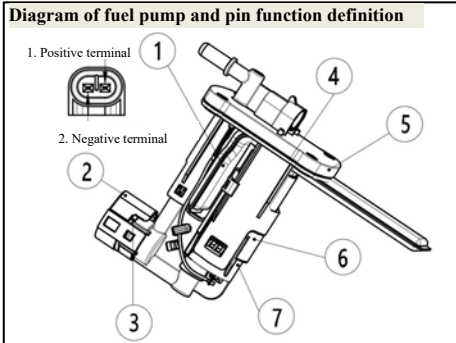

S/N	Component Name
1	Strainer
2	Adjusting valve clip
3	Pressure regulator
4	Sealing washer
5	Flange cover assembly
6	Bracket
7	Pump cell

Fuel Pump Basic Parameters Table

Name	Voltage (V)	Test Pressure (kPa)	Flow (L/h)	Current (A)
Fuel pump assembly	DC12	250±10	≥30	≤2.5
Pump cell	DC12	300±10	≥30	≤2.5
Shut-off pressure	DC8	100kPa		

※ **Fuel pump assembly**

The fuel pump assembly integrates the fuel pump, plastic bracket, full-flow filter, fine filter and pressure regulating valve. The working process is to use the certain oil pressure and flow to pump the fuel from the fuel tank to the engine.

Function definitions of pins:

- 1: Connect to the output terminal of the oil pump relay (Br/G);
- 2: Connect to the negative battery electrode (G).

Performance parameters:

Pressure regulating valve: at a flow rate of 40L/h, the corresponding rated pressure is 300 ± 10 kPa

Notes

- This fuel pump is installed at the bottom of the vehicle's fuel tank. Do not operate the fuel pump in a no-load or fuel-free state to prevent damage;
- Handle with care during installation or disassembly, and do not drop it to the ground.

Measure oil pressure

Connect the oil pressure gauge to the fuel outlet of the fuel pump assembly, and lock it with a clamp to ensure that there is no leakage at the junction. Press the stop switch, and the fuel pump will stop running after an operation of 5 seconds. Now measure to check that the oil pressure reaches the specified pressure value (300 kpa). If so, it indicates that the fuel pump is in good condition, on the contrary, it indicates that the fuel pump is in abnormal condition and needs to be replaced.

Pressure relief of fuel line

The fuel supply pressure of the electronic fuel injection system is high. All fuel pipes are made of high-pressure resistant hoses. Even when the engine is not running, there is still a relatively high pressure in the oil circuit. Therefore, note during maintenance: do not disassemble the fuel pipes easily; when maintaining the fuel system that needs repair, relieve the pressure of the fuel system before disassembling the fuel pipes and the methods are as follows: remove the fuel pump relay or the 2P (black) wire harness connector of the fuel pump, start the vehicle and let it idle until the engine shuts off on its own.

※ **Engine water temperature sensor**

The working principle of this sensor is based on a negative temperature coefficient thermistor (NTC). The sensor is installed on the water jacket of the engine block or cylinder head, in direct contact with the cooling water, so as to measure the temperature of the engine cooling water. The electronic control unit (ECU) measures the temperature of the engine cooling water according to this change and sends it to the instrument via CAN signal for displaying the current water temperature and water temperature alarm.

Function definitions of pins:

A: GND signal - connected to ECU 9 (J1) pin (G/B)
C: Sensor signal + connected to ECU 6 (F1) pin (Gr/G)

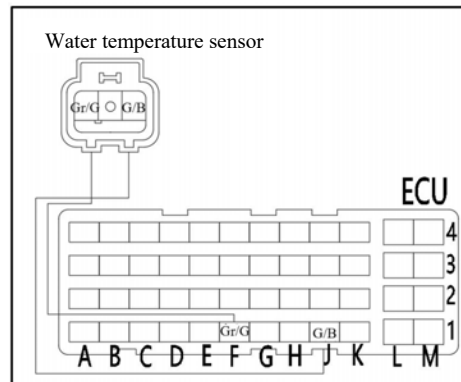
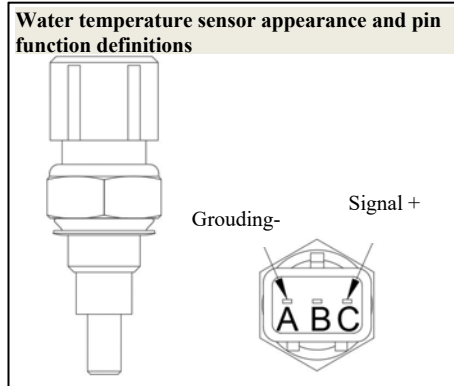

As shown in the right figure: Wiring diagram for water temperature and ECU.

Temperature range °C	Resistance value (kΩ) (Pin)
20	2.43±0.122
80	0.31±0.016
100	0.18±0.009
110	0.14±0.007

As shown in the water temperature sensor characteristic table on the right, different temperatures correspond to different resistance signals.

Resistance of water temperature sensor:
Below 20°C: 2308–2552Ω
Below 100°C: 171-189Ω

※ Power supply system

Charging Circuit Diagram

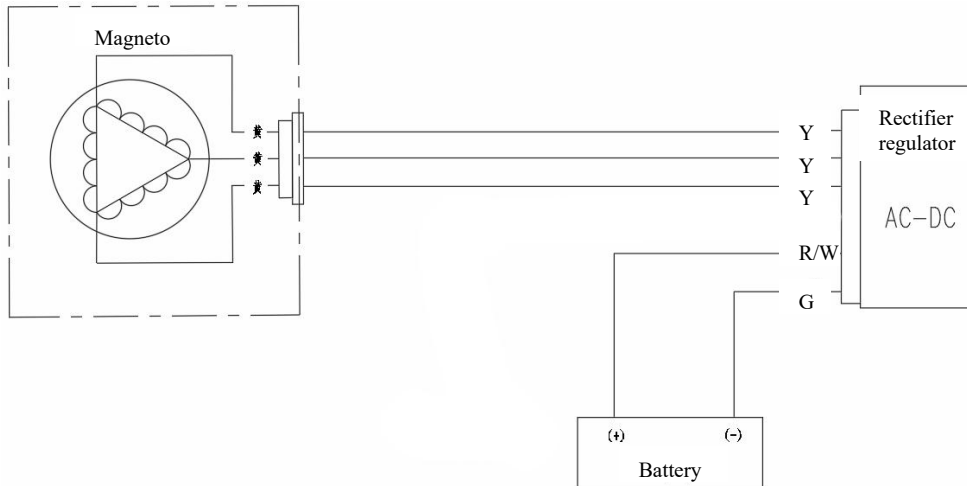

※ Magneto

Magneto coil resistance

Measure the resistance between magneto stator coils, if within the specified range, it indicates that the magneto is in good condition; On the contrary, it indicates an abnormality and an immediate replacement is required;

Normal resistance range of magneto coil:

$0.2\Omega \pm 20\%$ (Y/Y):

Insulation resistance $\infty \Omega$ (Y-grounding):

When checking, turn the multimeter to the gear $1 \times 10 \Omega$.

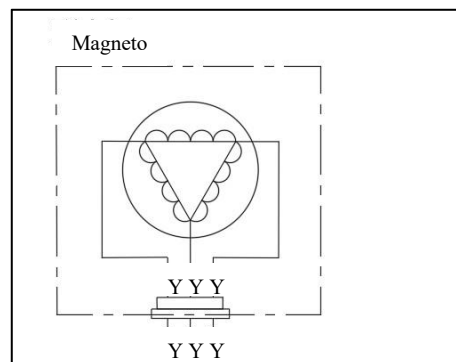

Performance of magneto under load

Start the engine, use a multimeter to measure and check for consistent voltage among the three output lines of the magneto stator coil, if consistent, it indicates that the magneto is in good condition; if not, it indicates an abnormality and a replacement is required;

Charging performance

Speed (rpm) 8000

Output current (A) ≤ 8.5 A

※ **Regulating rectifier**

The engine generally runs at 5,000r/min, in a fully charged state of battery, use a multimeter to measure the voltage at positive and negative ends of battery, which is 13.8V-14.8V.

Figure 1: Drawing of regulating rectifier and definition of pins

Figure 2: Test wiring diagram of regulating rectifier.

Function definitions of pins:

- 1: IN1 connected to magneto input (Y)
- 2: IN2 connected to magneto input (Y)
- 3: IN3 connected to magneto input (Y)
- 4: GND connected to battery: negative terminal (G)
- 5: Load (Br/G)
- 6: OUT connected to battery positive terminal (R/W)

Specification parameters:

- 1. Operating voltage: 12V;
- 2. Operating mode: three-phase full-wave;
- 3. Voltage regulation method: Short circuit grounding type (MOSFET);
- 4. Maximum adjustable current: 20A.

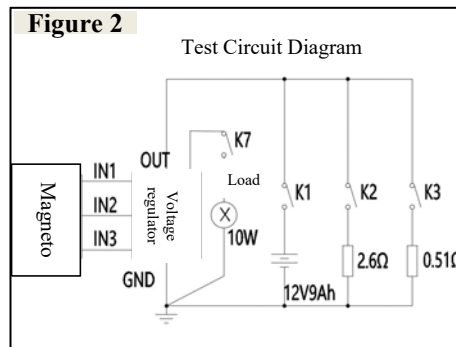
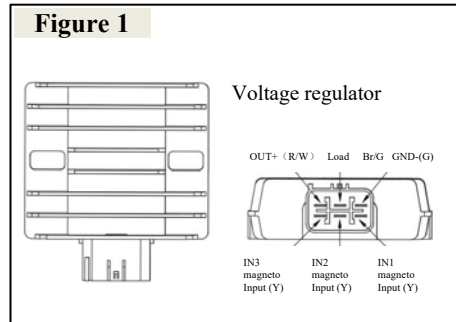

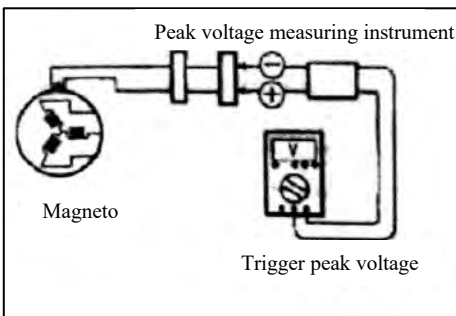
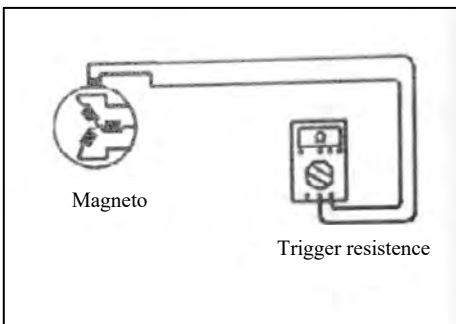
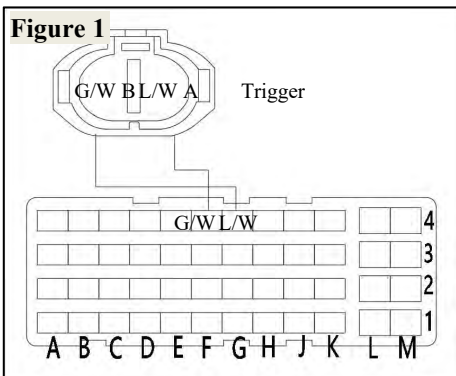
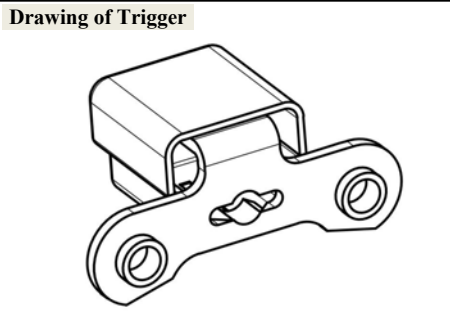

※ **Trigger**

It provides engine speed signal to ECU, and the ECU determines the ignition angle and fuel injection phase, etc. based on the signal.

Figure 1: Wiring diagram between trigger and ECU.

Measure the resistance value of trigger unit:

Set the multimeter to the 1X200Ω range:
 Trigger coil resistance: 100Ω-180Ω (20°C)
 If the resistance value of trigger unit is not within the above range, replace the trigger unit.

Measure the peak voltage of trigger unit
 Connect the multimeter to the peak voltage adapter as shown in the figure:
 + Probe: green-white (A) lead
 - Probe: blue-white (B) lead

Multimeter voltage is set to the AC gear:
 Set the engine in neutral, press and hold the start button to make the engine running for a few seconds, and then measure the trigger coil voltage:
 Repeat the measurement several times, and the measured highest output voltage of trigger coil is $\geq 2V$ (200r/min)

※ **Starting relay**

Apply DC12V to the contacts at both ends of the control circuit coil of starting relay, and measure with a multimeter to check for interconnection between the contacts (B and M) :

If the relay contacts make a tick sound and the multimeter makes a continuous beep sound, it indicates that the two contacts are interconnected, if not, it indicates that they are not interconnected. if there is no DC12V voltage applied to two ends of the coil, the two contacts are not interconnected:

The above two items can be used to confirm whether the relay is in good condition, and the multimeter should be set to the on-off gear during the measurement

Drawing of Starting Relay

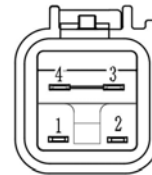
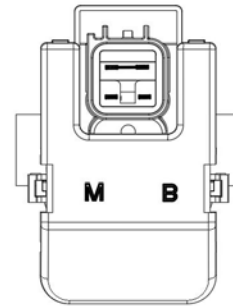

PIN Pin Definition

1	2	3	4	Terminal B	Terminal M
Coil power supply+ (R/W)	Coil ground (V-R)	Fuse power supply (R/W)		Power+	Ground



- The time for applying voltage to the relay coil shall not exceed 1 minute, otherwise it may cause overheating and even burnout of the coil.

As shown in the right figure: Wiring diagram of starting relay.

When measuring the resistance between relay coils using a multimeter, if the resistance is not within the specified range of 3Ω-5Ω, replacement with new parts is need.

Measure with the multimeter set to the 200Ω range.

As shown in the right figure: Circuit diagram of starting relay.

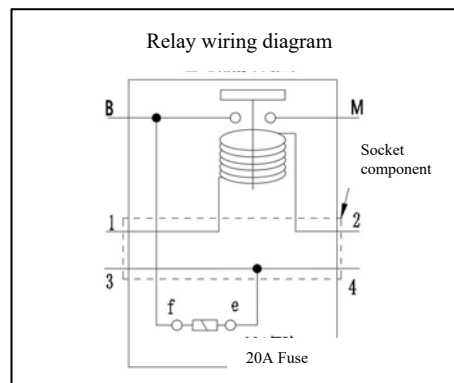

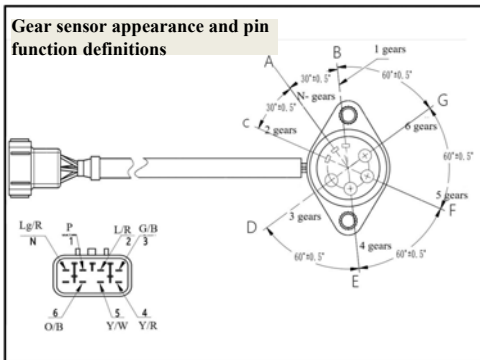
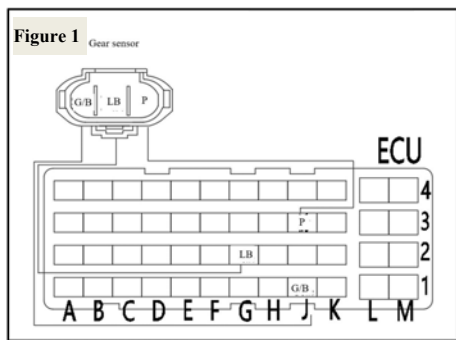
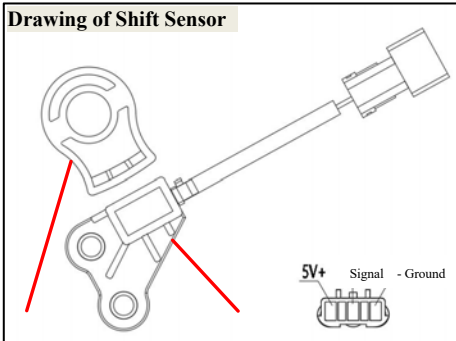

※ Shift sensor (quick shifter)

Quickly upshift without operating the clutch, as the clutch lever does not need to be engaged, allowing for uninterrupted continuous shifting.

Notes

1. This function will not operate when upshifting with the throttle off.
2. When operating the clutch lever, this function will not operate.

Notes

- If there is a malfunction in the quick shifting system.

Inspection

1. Check if the quick shifting sensor[1] and magnet seat [2] sensing area are contaminated with foreign matter;
2. Check if the sensor is installed in the correct position, ensuring it is centered between the sensor and the magnet seat.
3. Sensor connection wiring.
4. If the above inspections are completed and it still does not work properly, please replace the quick shifting component.

As shown in Figure 1: Quick shifting sensor wiring diagram.

※ Gear sensor

1. Inspection:

- Check the gear sensor line for open circuit or short circuit.
- Connection of gear sensor connector.
- Check the fixing condition of the harness connector.
- Remove the connector and check each pin inside the join

(Check for any bent or damaged terminals, and verify the security of each pin).

- Sensor mounting bolt M4, with a torque of 4-6 N•m.

2. Inspection:

- Whether the contact is conductive to the wire

Multimeter positive + probe

Y/R [4]

Multimeter negative - probe

Contact [E]

- Gear sensor

If out of specification → Replace the gear sensor.

※ **Battery**



- The negative wire must be disconnected before disassembling the battery, otherwise the battery will be short-circuited.

Disassembly/installation

Disassemble the following parts:

- After the vehicle get stall;
- Step screw [1];
- Battery box cover[2];
- Disconnect the negative battery electrode (-) cable with screw [3].
- Disconnects the positive (+) cable with screw [4];
- Remove the battery rubber grommet [5].

Note

- Battery is designed with over-charge protection, and the voltage for over-charge protection is 15.3V-15.9V.

Charging

- Turn off the vehicle and disconnect the positive and negative electrodes of the battery from the battery terminals.
- Remove battery;
- Connect the charger to the battery, turn on the charger
- When the charging is completed, turn off the charger, and unplug it from the battery;

Notes

- If the vehicle is not in use, recharge its battery every 3 months.

Check charging voltage

The battery must function properly and be fully charged.

Start the vehicle for a voltage test;

Measuring point positive (+), measuring point grounding (-).

Notes

- When measuring the battery voltage after charging, it shall be maintained for at least 30 minutes, otherwise accurate results cannot be obtained due to battery voltage fluctuations after charging.

Charging voltage	
5000rpm	13.9-14.9 V

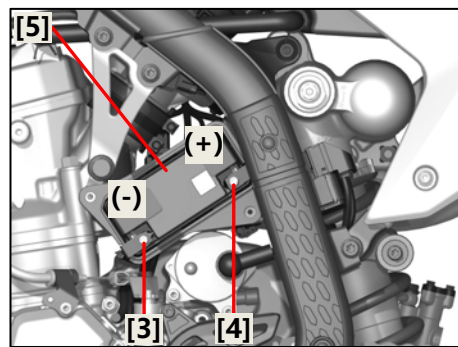
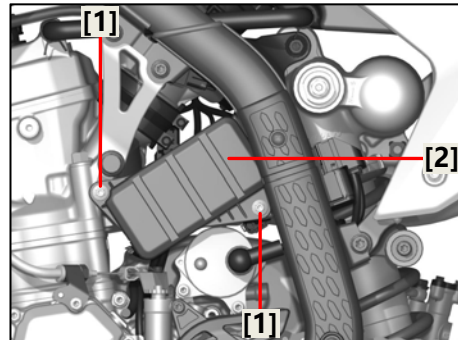

Torque:

Battery box cover mounting bolts

5.0 N·m (0.5 kgf·m, 3.7 lbf·ft)

Battery terminal mounting screw

5.0 N·m (0.5 kgf·m, 3.7 lbf·ft)

Battery specification:

Battery model: HJ12-FPZ (lithium battery)

Full charging voltage: > 13.2V

Required charging voltage: < 12.8V

Charging current: standard 1.2A, max. 12.0A

Operating temperature: -20°C - 60°C

Battery capacity: 12V/2.3Ah

Overall dimension: Length x Width x

Height:112x49x85(±1mm)

※ **Handlebar switch-left**

Disconnect the plug connector linking the left handlebar switch harness to the main cable, and check the ON/OFF status of each switch action.

1. Engine mode **M** button [2]; (self-reset)
2. Launch control **L** button [1]; (self-resetting)
3. Timer **Ti** button [3]; (self-reset)
4. Functional display screen component [4];
5. Reserved button with no functionality [5]. (self-reset)

Check for any connector malfunctions such as: pin retraction, crooked pins, improper plugging, etc.

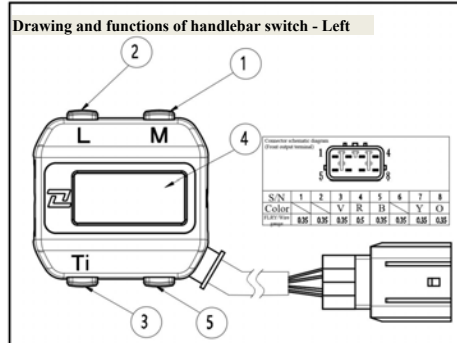

Left figure: Function and wire color correspondence table of handlebar switch (left).

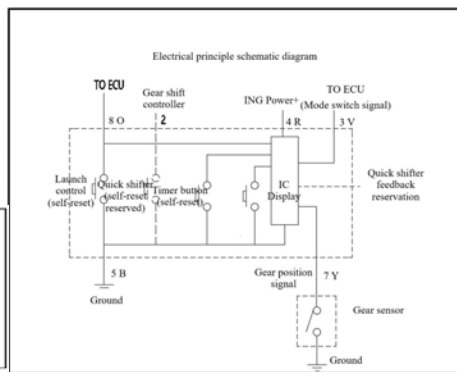
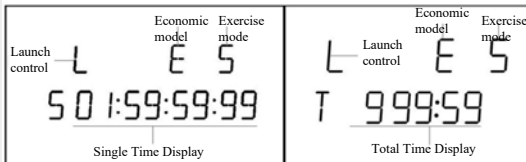

Display logic for the screen:

The vehicle powers on, and the screen starts working to display.

1. Engine mode (M)
 - 1.1 Press the switch once, and the switch continuously outputs a ground signal to the ECU. At this time, it is in SPORT mode, and the display continuously shows the "S" icon.
 - 1.2 Press again to disconnect the output signal, entering ECO mode, where the display continuously shows the "E" icon;
 - 1.3 This function retains memory of the last operating condition before power-off.
 2. Launch control (L)
 - 2.1 When no low-level gear signal is received, long press the button for 3 seconds. During this time, the "L" icon on the display will flash once per second until the 3-second press ends, then the "L" icon will light up, indicating the launch control function is activated;
 - 2.2 Upon receiving the low-level gear signal, the "L" icon extinguishes. When the low-level gear signal remains active, long press the launch button, and the "L" icon will flash at a frequency of 2 times per second, indicating that the "L" icon cannot be activated.
 - 2.3 During launch control activation, if the low-level gear signal is not detected, pressing the button again will not deactivate the "L" icon. Do no reminder.
 3. Timer button (Ti)
 - 3.1 The default display upon power on is the single-timer interface;
 - 3.2 Click the timer button: On the single-timer display interface, click the timer button to start the timer, and click again to pause at the current time
Pause for reading; click again to resume timing from the current time.
Long press (1s): Used to toggle between the single timer and total timer interfaces;
Long press (3s): Resets the single timer. Long pressing on the total time interface will return to the single timer interface and reset it;
 - 3.4 Total time: The cumulative upper limit is 999 hours and 59 minutes, and it stops at 999:59;
 - 3.5 The total time and individual timing are independent of each other. The total timing starts counting when the screen is powered on and records every minute, retaining the count when powered off.
- Powering off for less than one minute is ignored and not counted in the total minutes.

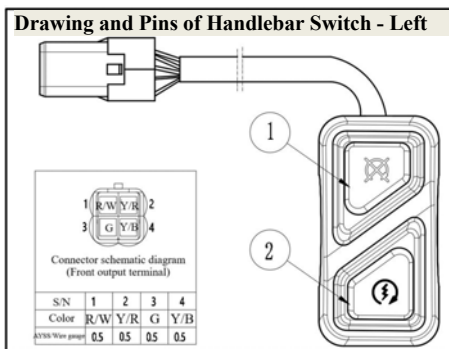
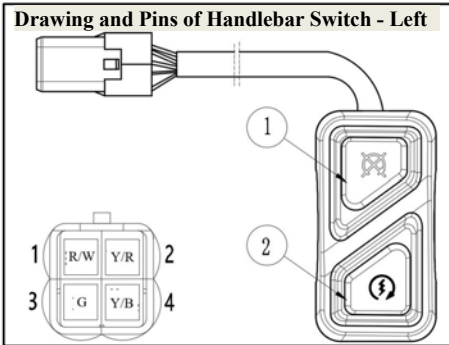

Functional On/Off Diagram

Wire gauge	FRYL 0.5		FRYL 0.35		Icon color
Wire color	Y/R	G	Y/B	G	
Function					
					W
					W
Function definition	TO starting relay coil	Power supply	TO 6-pin relay coil		

※ **Handle switch-right**

Disconnect the plug connector linking the right handlebar switch harness to the main cable, and check the ON/OFF status of each switch action.

1. Electric starter button[1]: (self-reset)

When this button is pressed, the engine starts.

With the engine in neutral or the clutch engaged, press this button to start the engine.

2. Stop button[2]: (self-reset)

When this button is pressed, the engine will stall.

3. Buttons [1] and [2] are initially in the open state and close when pressed.

Inspection:

Check for any connector malfunctions such as: pin retraction, crooked pins, improper plugging, etc.

As shown in the left figure: ON/OFF schematic diagram of handlebar switch (right)

Abbreviation letters corresponding to wire colors:

B	Black	Y/G	Yellow/Green
Br	Brown	Y/L	Yellow/Blue
G	Green	Y/W	Yellow/White
Gr	Grey	Y/Br	Yellow/Brown
L	Blue	Y/Gr	Yellow/Grey
O	Orange	O/B	Orange/Black
P	Pink	O/W	Orange/White
R	Red	O/L	Orange/Blue
Lb	Light Blue	W/Br	White/Brown
W	White		
Y	Yellow		
V	Purple		
Lg	Light Green		
Lg/R	Light Green/Red		
V/B	Purple/Black		
V/Y	Purple/Yellow		
V/G	Purple/Green		
B/L	Black/Blue		
B/W	Black/White		
B/Y	Black/Yellow		
Br/R	Brown/Red		
Br/B	Brown/Black		
Br/L	Brown/Blue		
G/L	Green/Blue		
G/W	Green/White		
G/Gr	Green/Grey		
Gr/G	Grey/Green		
Gr/Y	Grey/Yellow		
Gr/W	Grey/White		
Gr/L	Grey/Blue		
L/B	Blue/Black		
L/W	Blue/White		
P/B	Pink/Black		
P/L	Pink/Blue		
P/R	Pink/Red		
P/W	Pink/White		
P/G	Pink/Green		
R/B	Red/Black		
R/Y	Red/Yellow		
R/V	Red/Purple		
W/P	White/Pink		
W/G	White/Green		